



PARTS CATALOGUE

PAS ATTACHMENT SBE-SRM(PAS-Edger)

SBE-SRM(PAS-Edger)

1. Main Pipe, Gear Case

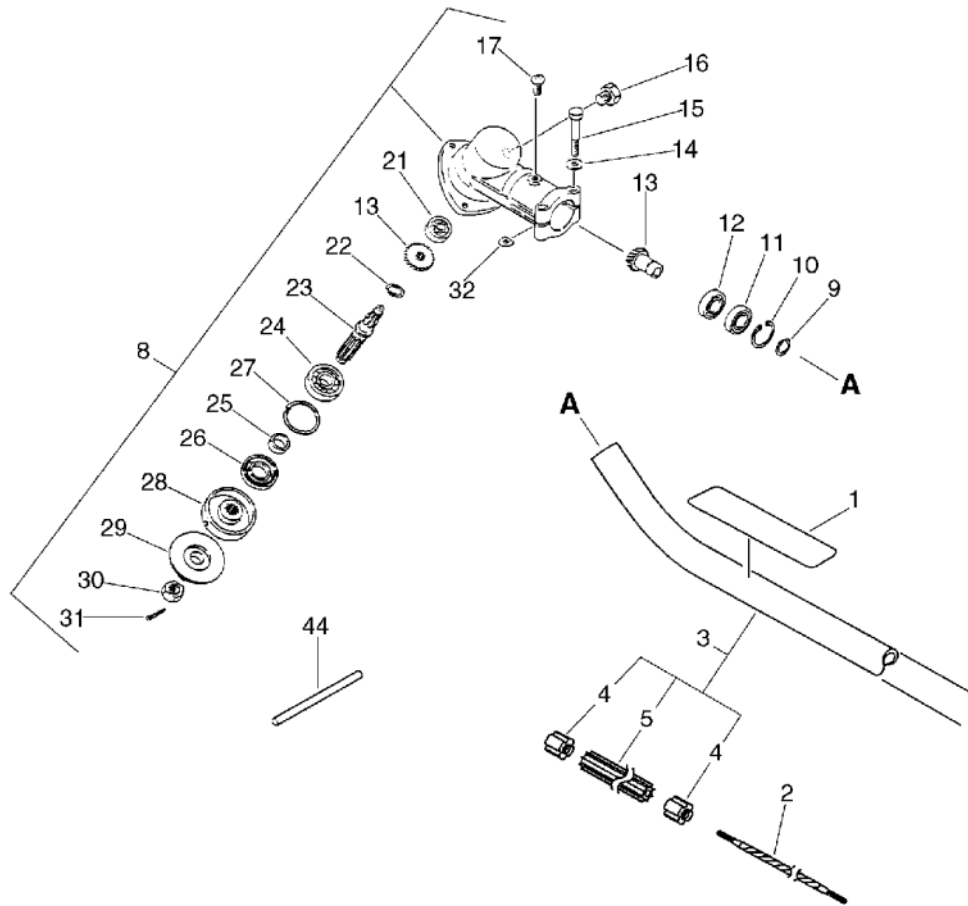

KEY	LV	PART NUMBER	Q'TY	DESCRIPTION	REMARKS	NOTE1	NOTE2
1		890617-55630	1	LABEL, CAUTION		Sus. by 890160-25560	
1		890160-25560	1	LABEL, CAUTION			
2		C506-000000	1	SHAFT,FLEXIBLE		Sus. by C506-000001	
2		C506-000001	1	SHAFT,FLEXIBLE		Sus. by C506-000002	
3		610206-46130	1	HOUSING ASY, D.SHFT			
4	+	610246-44730	2	STOPPER			
5	+	610217-52630	1	LINER, FLEXIBLE			
8		610402-52631	1	CASE ASY, GEAR		Sus. by 610402-52633	
8		610402-52632	1	CASE ASY, GEAR		Sus. by 610402-52633	
8		610402-52633	1	CASE ASY, GEAR			
9	+	900706-00012	1	CIRCLIP 12	WR-12		
10	+	900702-00022	1	CIRCLIP 22	CR-22		
11	+	900858-06900	1	BEARING, BALL 6900Z	6900Z		
12	+	900855-06900	1	BEARING, BALL 6900	6900		
13	+	610300-52630	1	GEAR SET			
14	+	900600-00005	2	WASHER 5	5		
15	+	900100-05030	2	BOLT 5*30	5*30		
16	+	610434-50030	1	BOLT 8* 6		Sus. by 610434-50031	
16	+	610434-50031	1	BOLT 8* 8	M8*8		
17	+	900242-05010	1	SCREW 5*10	5*10		

1. Main Pipe, Gear Case

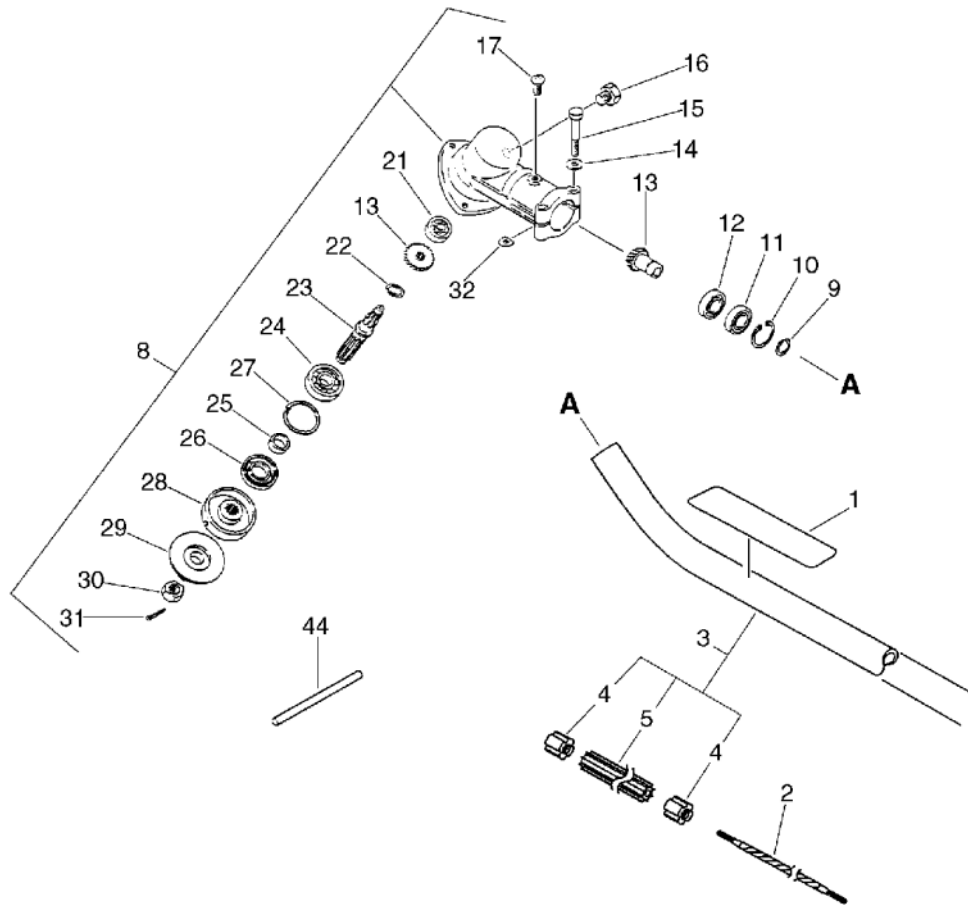

KEY	LV	PART NUMBER	Q'TY	DESCRIPTION	REMARKS	NOTE1	NOTE2
21	+	900800-00609	1	BEARING, BALL 609	609		
22	+	900706-00010	1	CIRCLIP 10	WR-10		
23	+	610360-08931	1	SHAFT, P.T.O.			
24	+	900810-06201	1	BEARING, BALL 6201	6201		
25	+	610315-07130	1	SPACER			
26	+	610413-07130	1	OILSEAL			
27	+	900702-00032	1	CIRCLIP 32	CR-32		
28	+	610313-07130	1	PLATE, ADAPTER (U)	PD 25.4	Sus. by 610313-07131	
28	+	610313-07131	1	PLATE, ADAPTER (U)	PD 25.4		
29	+	610314-04131	1	PLATE, ADAPTER (L)			
30	+	900513-00010	1	NUT 10*1.25 3N L-H	3N10*1.25		
31	+	900300-20022	1	PIN, SPLIT 2*22	2*22		
32	+	610239-04130	2	WASHER, SHIM			
44		897518-01131	1	LOCKING TOOL			

2. Shield, Wheel, Blade

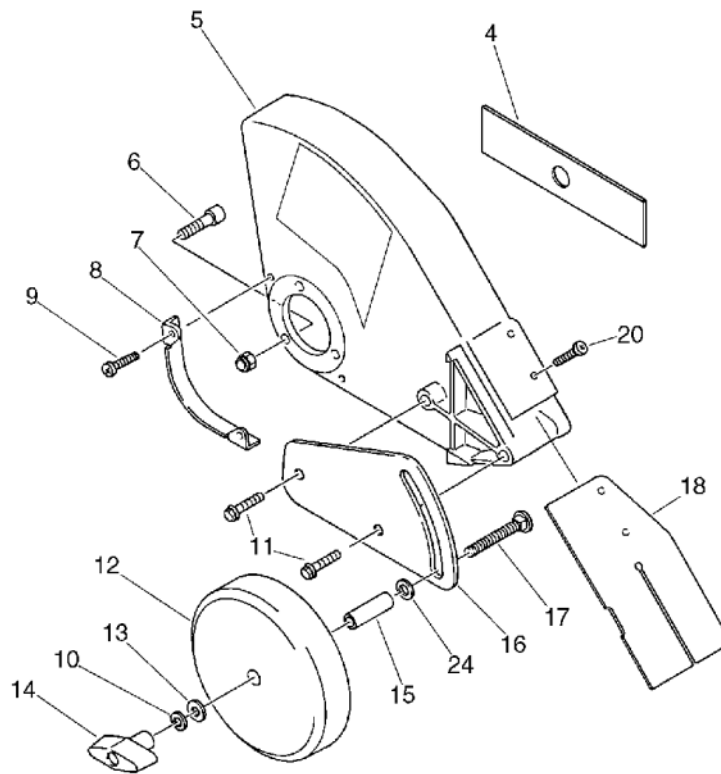

KEY	LV	PART NUMBER	Q'TY	DESCRIPTION	REMARKS	NOTE1	NOTE2
4		696015-52632	1	2-CUTTER BLADE QTY-2			
5		699010-52630	1	SHIELD, BLADE			
6		900162-05022	3	BOLT, H.S. 5*22	5*22 W,SW		
7		900562-50005	3	LOCKNUT 5	5		
8		699025-52630	1	PLATE, PROTECTION			
9		900080-00300	2	SCREW,4*16	+4*16		
10		900605-00008	1	WASHER, SPRING 8	8		
11		900080-00100	2	SCREW, 8	6カ5/16*8		
12		302410-52631	1	WHEEL 6*1.5		Sus. by C730-000030	
12		C730-000030	1	WHEEL	GRAY HUB		
13		900602-00008	1	WASHER 8	8.4*17*1.6		
14		178113-55330	1	NUT, WING	5/16-18		
15		302424-52630	1	COLLAR, 12			
16		302029-55330	1	BRACKET, WHEEL		Sus. by 302029-55332	
16		302029-55331	1	BRACKET, WHEEL		Sus. by 302029-55332	
16		302029-55332	1	BRACKET, WHEEL			
17		610250-55330	1	BOLT			
18		699017-55330	1	SHIELD, BLADE			
20		900080-00200	2	SCREW,4*20	+4*20		
24		900602-00010	1	WASHER 10(10.5*21*2)	10.5*21*2		

Index

Patrs Number	Key No.	Patrs Number	Key No.	Patrs Number	Key No.
178113-55330	2 - 14	900855-06900	1 - 12		
302029-55330	2 - 16	900858-06900	1 - 11		
302029-55331	2 - 16	C506-000000	1 - 2		
302029-55332	2 - 16	C506-000001	1 - 2		
302410-52631	2 - 12	C730-000030	2 - 12		
302424-52630	2 - 15				
610206-46130	1 - 3				
610217-52630	1 - 5				
610239-04130	1 - 32				
610246-44730	1 - 4				
610250-55330	2 - 17				
610300-52630	1 - 13				
610313-07130	1 - 28				
610313-07131	1 - 28				
610314-04131	1 - 29				
610315-07130	1 - 25				
610360-08931	1 - 23				
610402-52631	1 - 8				
610402-52632	1 - 8				
610402-52633	1 - 8				
610413-07130	1 - 26				
610434-50030	1 - 16				
610434-50031	1 - 16				
696015-52632	2 - 4				
699010-52630	2 - 5				
699017-55330	2 - 18				
699025-52630	2 - 8				
890160-25560	1 - 1				
890617-55630	1 - 1				
897518-01131	1 - 44				
900080-00100	2 - 11				
900080-00200	2 - 20				
900080-00300	2 - 9				
900100-05030	1 - 15				
900162-05022	2 - 6				
900242-05010	1 - 17				
900300-20022	1 - 31				
900513-00010	1 - 30				
900562-50005	2 - 7				
900600-00005	1 - 14				
900602-00008	2 - 13				
900602-00010	2 - 24				
900605-00008	2 - 10				
900702-00022	1 - 10				
900702-00032	1 - 27				
900706-00010	1 - 22				
900706-00012	1 - 9				
900800-00609	1 - 21				
900810-06201	1 - 24				

YAMABIKO CORPORATION

7-2 SUEHIROCHO 1-CHOME, OHME, TOKYO 198-8760, JAPAN
PHONE: 81-428-32-6118. FAX: 81-428-32-6145.



No. ger)