



PARTS CATALOGUE

HEDGE TRIMMER HC-2300,2300(W)

HC-2300,2300(W)

1. Cylinder, Crankcase, Piston

No.1

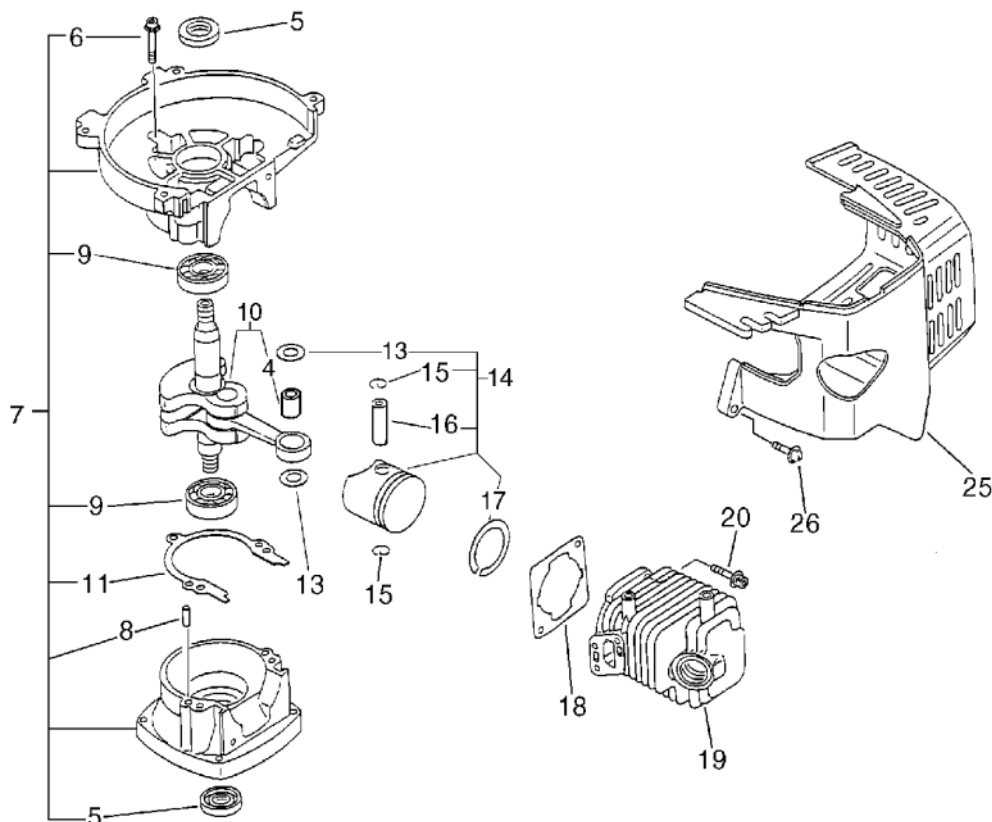

KEY	LV	PART NUMBER	Q'TY	DESCRIPTION	REMARKS	NOTE1	NOTE2
7		100204-51030	1	CRANKCASE KIT		Sus. by 100204-51031	
7		100204-51031	1	CRANKCASE KIT			
5	+	100212-42030	2	OILSEAL	ISCD12*22*4.5	Sus. by 100212-42031	
5	+	100212-42031	2	OILSEAL	ISCD 12*22*4.5		
6	+	900238-05028	3	SCREW 5*28	5*28	Sus. by 900162-05028	
6	+	900162-05028	3	BOLT, H.S. 5*28	5*28 W,SW		
8	+	100215-03930	2	PIN, DOWEL			
9	+	900810-36201	2	BEARING, BALL 6201	6201/C3	Sus. by 94035-36201	
9	+	94035-36201	2	BEARING BALL	6201X3JR2C3		
11	+	100242-42030	1	GASKET, CRANKCASE			
10		100100-05962	1	CRANKSHAFT ASSY		Sus. by 100100-05963	
10		100100-05963	1	CRANKSHAFT			
4	+	100012-51230	1	BEARING, NEEDLE	8*12*10	Sus. by V553-000010	
4	+	V553-000030	1	BEARING,NEEDLE 8		Sus. by V553-000010	
4	+	V553-000010	1	BEARING,NEEDLE 8	HK0810		
14		100000-44330	1	PISTON KIT		Sus. by 100000-44331	
14		100000-44331	1	PISTON KIT			

1. Cylinder, Crankcase, Piston

No.1

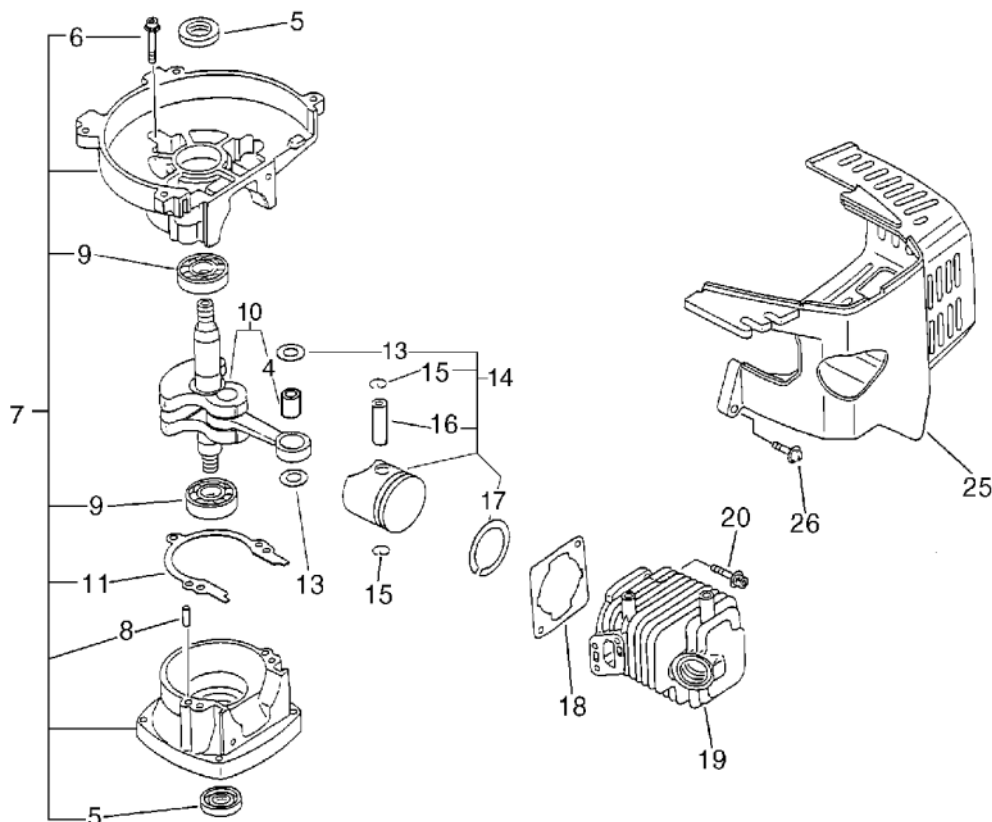

KEY	LV	PART NUMBER	Q'TY	DESCRIPTION	REMARKS	NOTE1	NOTE2
13	+	100014-11520	2	SPACER, PISTON PIN			
15	+	100015-04630	2	CIRCLIP, PISTON PIN			
16	+	100013-11520	1	PIN, PISTON			
17	+	100011-05330	1	RING, PISTON			
18		101010-44331	1	GASKET, CYL. BASE		Sus. by 101010-44332	
18		101010-44332	1	GASKET, CYL. BASE			
19		101011-45230	1	CYLINDER			
20		900162-05022	2	BOLT, H.S. 5*22	5*22 W,SW		
25		101514-05960	1	COVER, CYLINDER			
26		900238-04022	2	SCREW 4*22	4*22		

2. Starter, Magneto, Clutch

No.2

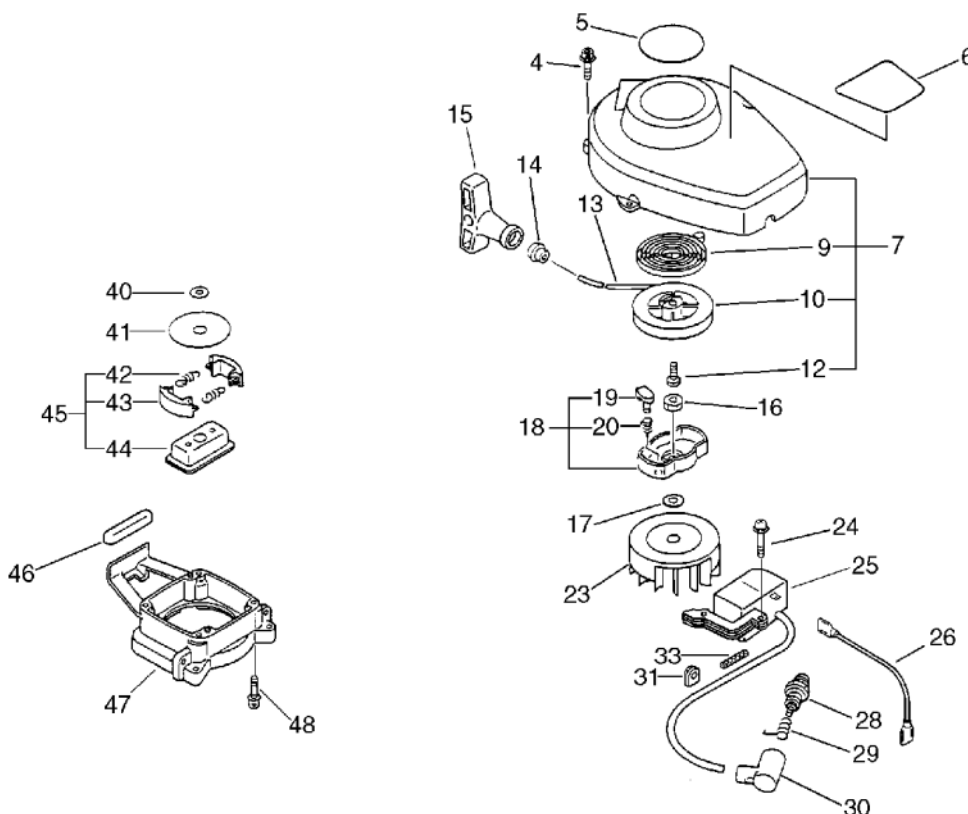

KEY	LV	PART NUMBER	Q'TY	DESCRIPTION	REMARKS	NOTE1	NOTE2
4		900238-04016	4	SCREW 4*16	4*16		
5		890118-49130	1	LABEL, ECHO		Sus. by 890112-07560	
5		890112-07560	1	LABEL, MODEL			
6		890112-07360	1	LABEL, MODEL HC-2300		Sus. by 890617-07660	
6		890112-07361	1	LABEL, MODEL		Sus. by 890617-07660	
6		890112-07362	1	LABEL, MODEL 1996		Sus. by 890617-07660	
6		890617-07660	1	LABEL, CAUTION			
7		177200-07162	1	STARTER ASSY			
9	+	177220-42030	1	SPRING, REWIND			
10	+	177215-05960	1	DRUM, STARTER			
12	+	177236-44330	1	SCREW			
13	+	177226-05960	1	ROPE, STARTER	3.5*830		
14	+	177227-42030	1	GUIDE, ROPE			
15	+	177228-06530	1	GRIP, STARTER			
16		900512-00008	1	NUT 3N 8 (L-H)	3N 8		
17		900600-00008	1	WASHER 8	8		
18		177202-07360	1	PAWL ASSY, STARTER		Sus. by 177202-07361	
18		177202-07361	1	PAWL ASM., STARTER			
19	+	177218-44330	1	PAWL, STARTER	BLACK		
20	+	177234-05960	1	SPRING, RETURN		Sus. by P022-007980	

2. Starter, Magneto, Clutch

No.2

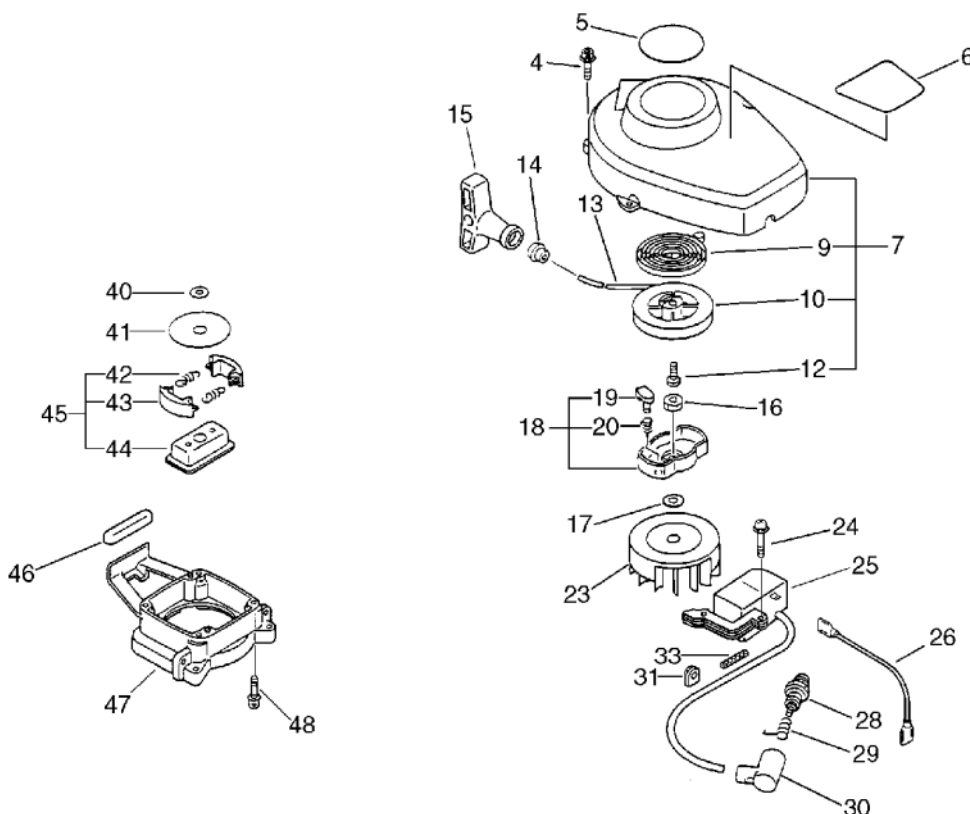

KEY	LV	PART NUMBER	Q'TY	DESCRIPTION	REMARKS	NOTE1	NOTE2
20	+	P022-007980	1	SPRING, RETURN			
23		156801-44730	1	FLYWHEEL		Sus. by 156801-44731	
23		156801-12360	1	ROTOR, MAGNETO		Sus. by 156801-44731	
23		156801-44731	1	FLYWHEEL			
24		900238-04022	2	SCREW 4*22	4*22		
25		156601-44730	1	COIL, IGNITION		Sus. by 156601-44731	
25		156601-44731	1	COIL, IGNITION		Sr/Nr 017876 and before	
25		156601-52130	1	COIL, IGNITION		Sr/Nr 017877 and after	
26		162010-52830	1	LEAD, GROUND		Sr/Nr 017877 and after	
28		159017-10230	1	PLUG, SPARK (RCJ-7Y)	RCJ-7Y		
29		159011-03432	1	COIL, SPARK PLUG			
30		159012-03433	1	CAP, SPARK PLUG			
31		156110-04920	1	BUSHING			
33		V475-001900	1	TUBE	7*8.6*30		
40		175014-05360	1	WASHER, CLUTCH	8.2*19*3.2		
41		175019-04920	1	PLATE, CLUTCH			
45		175000-02962	1	CLUTCH ASSY			
42	+	175018-05960	2	SPRING, CLUTCH			
43	+	175009-05131	2	SHOE, CLUTCH			
44	+	175016-07330	1	HUB, CLUTCH			

2. Starter, Magneto, Clutch

No.2

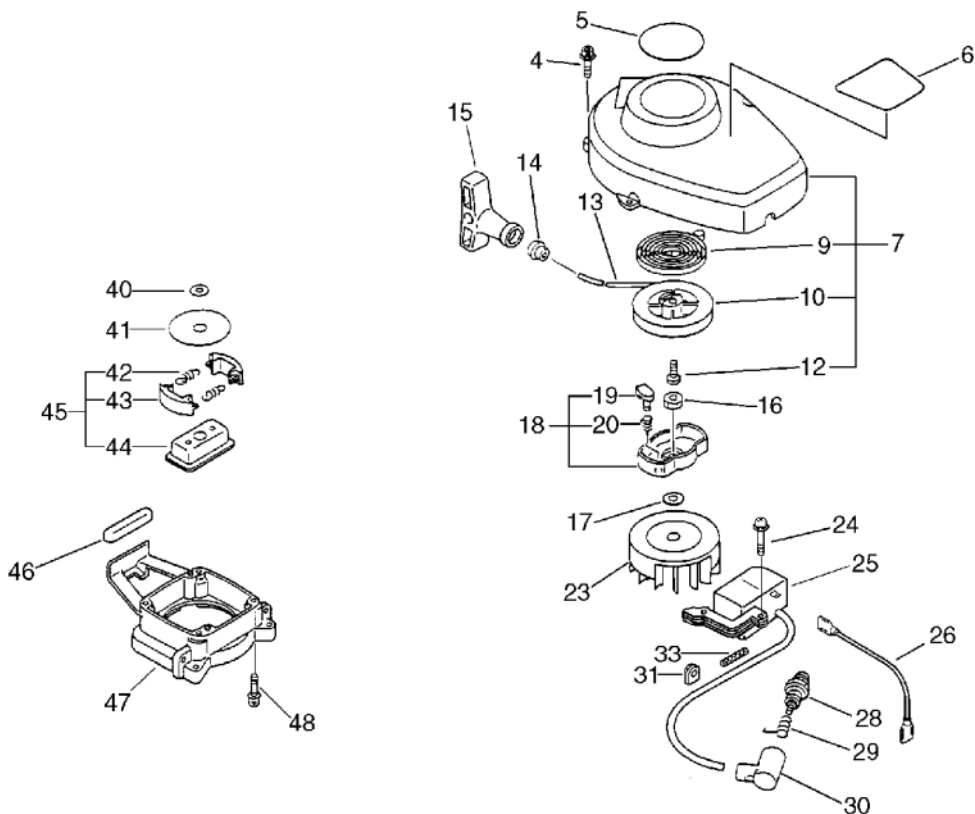

KEY	LV	PART NUMBER	Q'TY	DESCRIPTION	REMARKS	NOTE1	NOTE2
46		131920-28230	1	CUSHION, FUEL TANK			
47		610223-05960	1	CASE, CLUTCH			
48		900238-04016	4	SCREW 4*16	4*16		

3. Air Cleaner, Muffler

No.3

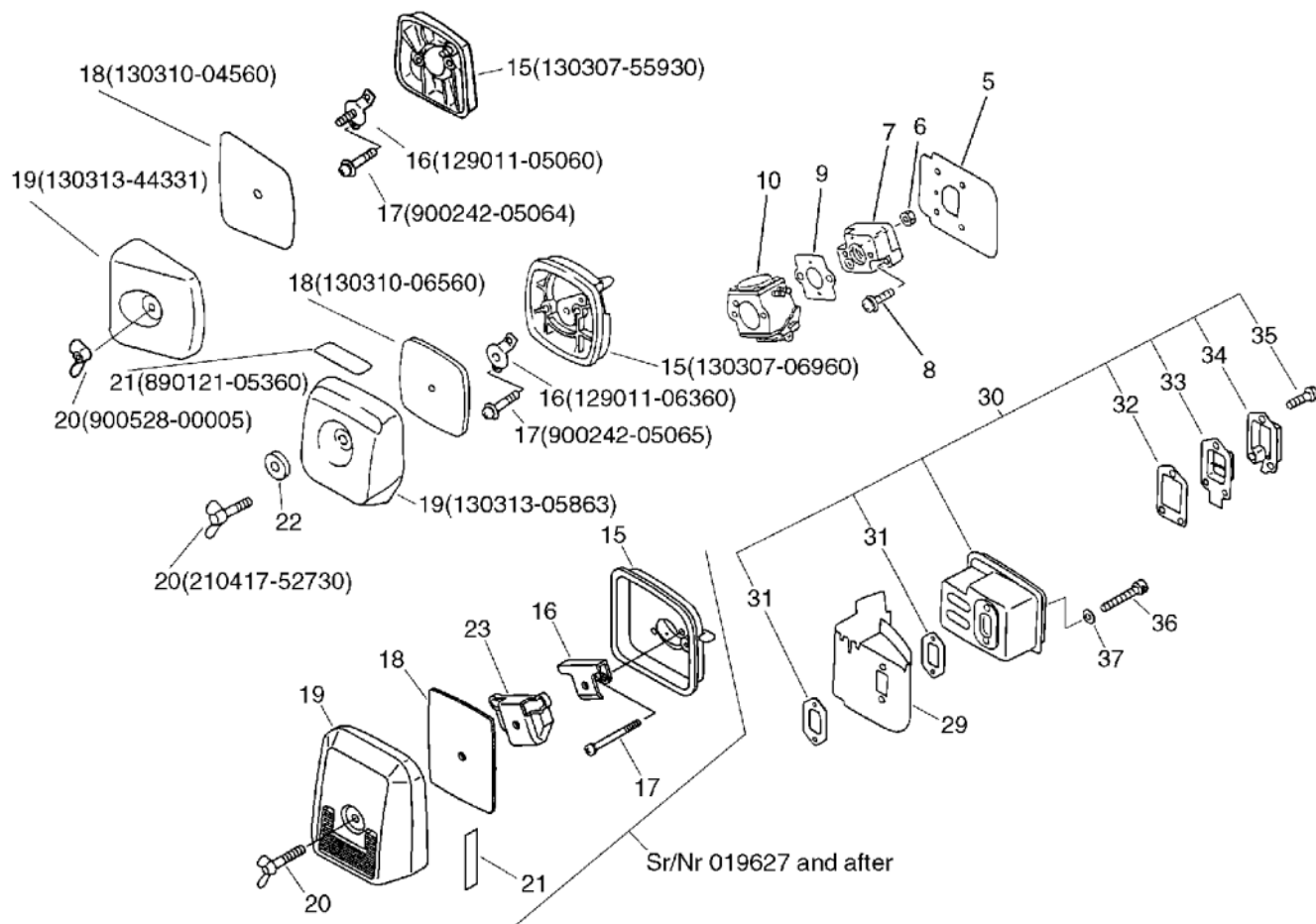

KEY	LV	PART NUMBER	Q'TY	DESCRIPTION	REMARKS	NOTE1	NOTE2
5		130010-42032	1	GASKET,INTAKE			
6		900500-00005	2	NUT 5	5		
7		130017-42031	1	INSULATOR, INTAKE			
8		900238-05020	2	SCREW 5*20	5*20		
9		130016-42031	1	GASKET, INTAKE			
10		125200-06961	1	CARBURETOR ASSY	C1U-K18	Sus. by 125200-05964	
10		125200-06962	1	CARBURETOR ASSY	C1U-K18A	Sus. by 125200-05964	
10		125200-05961	1	CARBURETOR C1U-K51	C1U-K51	Sus. by 125200-05964	
10		125200-05962	1	CARBURETOR	C1U-K51	Sus. by 125200-05964	
10		125200-05963	1	CARBURETOR C1U-K51	C1U-K51	Sus. by 125200-05964	
10		125200-05964	1	CARBURETOR	C1U-K51		
15		130307-05360	1	CASE, AIR CLEANER		Sus. by 130307-55930	
15		130307-55930	1	CASE, AIR CLEANER		Sr/Nr 007566 and before	
15		130307-06960	1	CASE, AIR CLEANER		Sr/Nr 007567 to 019626	
15		130307-09660	1	CASE ASSY, CLEANER		Sus. by 130307-09662	
15		130307-09661	1	CASE, AIR CLEANER		Sus. by 130307-09662	

3. Air Cleaner, Muffler

No.3

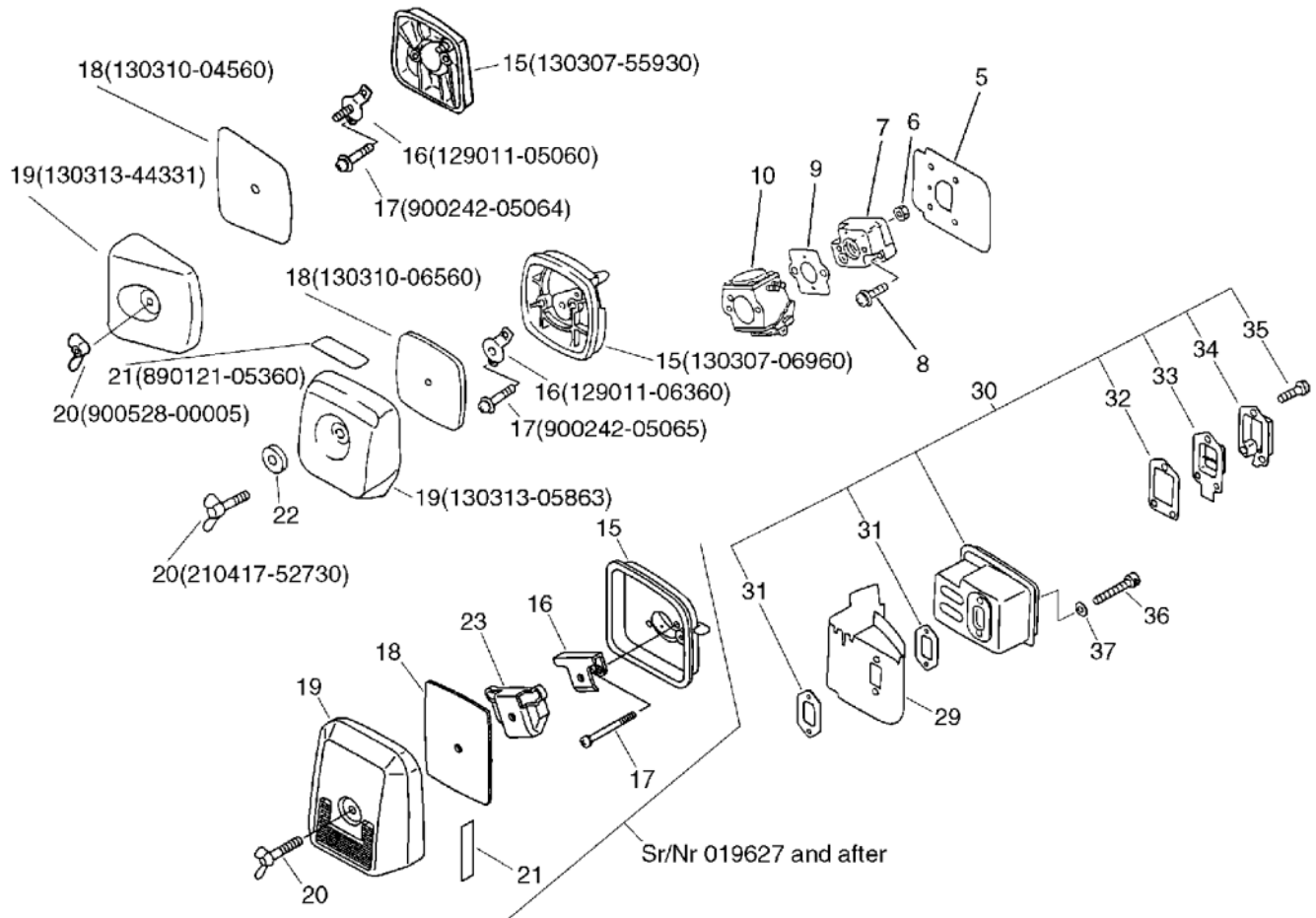

KEY	LV	PART NUMBER	Q'TY	DESCRIPTION	REMARKS	NOTE1	NOTE2
15		130307-09662	1	CASE, AIR CLEANER		Sr/Nr 019627 and after	
16		129011-05060	1	PLATE		Sr/Nr 007566 and before	
16		129011-06360	1	PLATE, PREVENT		Sr/Nr 007567 to 019626	
16		130422-09660	1	PLATE, PREVENT		Sr/Nr 019627 and after	
17		900242-05064	2	SCREW 5*64	5*64	Sr/Nr 007566 and before	
17		900242-05065	2	SCREW 5*65	5*65	Sr/Nr 007567 to 019626	
17		900242-05057	2	SCREW 5*57	5*57	Sr/Nr 019627 and after	
18		130310-04560	1	FILTER, AIR		Sr/Nr 007566 and before	
18		130310-06560	1	FILTER, AIR		Sr/Nr 007567 to 019626	
18		130310-51830	1	FILTER, AIR		Sr/Nr 019627 and after	
19		130313-44331	1	COVER, AIR CLEANER		Sr/Nr 007566 and before	
19		130313-05862	1	LID, CLEANER(ID1110)		Sus. by 130313-05863	
19		130313-05863	1	LID, AIR CLEANER		Sr/Nr 007567 to 019626	

3. Air Cleaner, Muffler

No.3

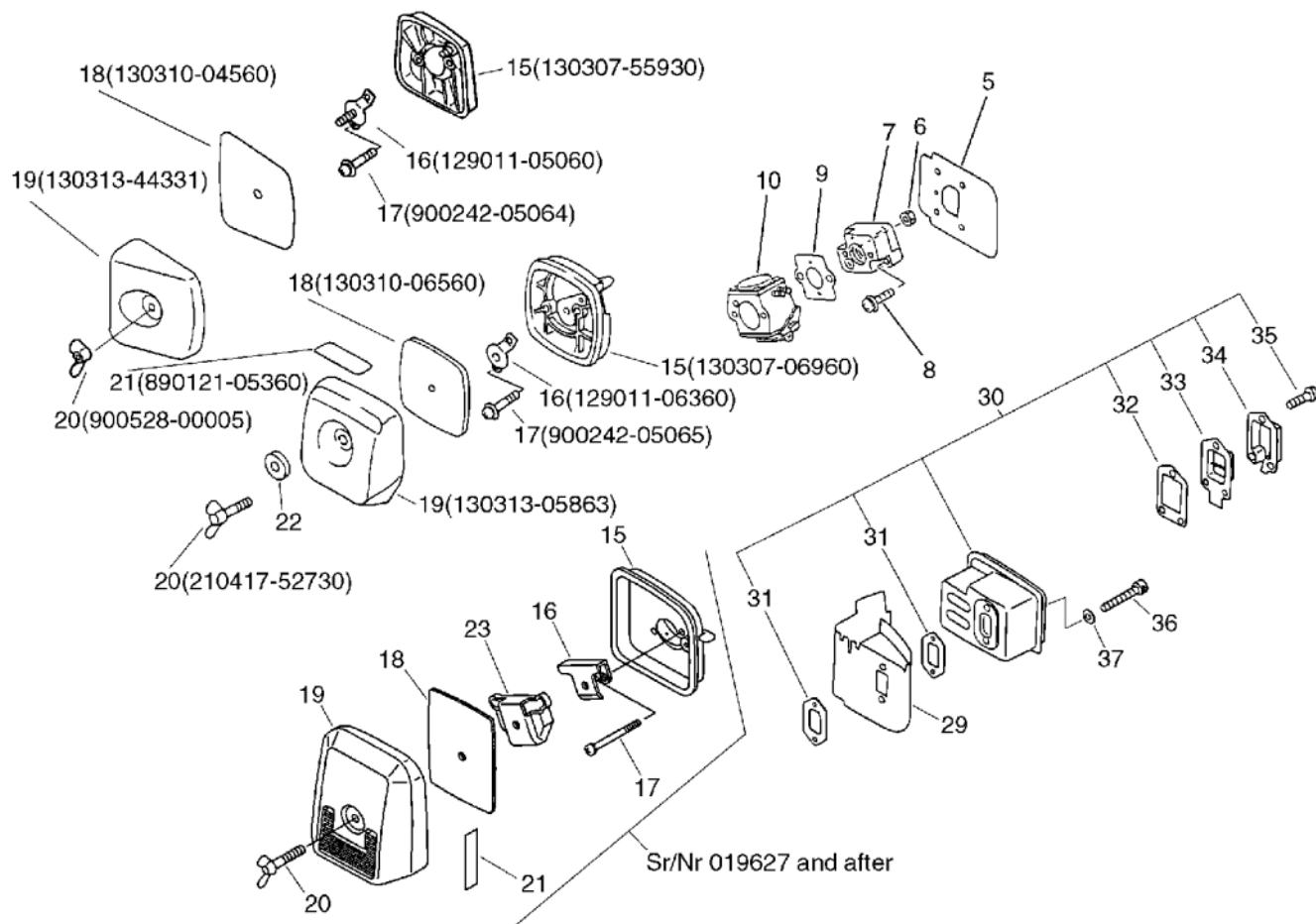

KEY	LV	PART NUMBER	Q'TY	DESCRIPTION	REMARKS	NOTE1	NOTE2
19		130313-09561	1	LID, CLEANER		Sr/Nr 019627 and after	
20		900528-00005	1	NUT	5	Sr/Nr 007566 and before	
20		210417-52730	1	BOLT, WING	5*20	Sr/Nr 007567 to 019626	
20		210417-09560	1	BOLD, WING	5*24	Sr/Nr 019627 and after	
21		890121-05360	1	LABEL, METERING		Sr/Nr 019626 and before	
21		890121-09560	1	LABEL, CHOKE		Sr/Nr 019627 and after	
22		610444-28230	1	SPACER		Sr/Nr 007567 to 019626	
23		129011-09560	1	PLATE		Sr/Nr 019627 and after	
29		145871-44331	1	COVER, MUFFLER		Sus. by A320-000251	
29		145631-42030	1	COVER, MUFFLER		Sus. by A320-000251	
29		A320-000250	1	COVER,MUFFLER		Sus. by A320-000251	
29		A320-000251	1	COVER,MUFFLER			
30		145802-05960	1	MUFFLER ASSY			
31	+	145510-42031	2	GASKET, MUFFLER		Sus. by V104-000160	

3. Air Cleaner, Muffler

No.3

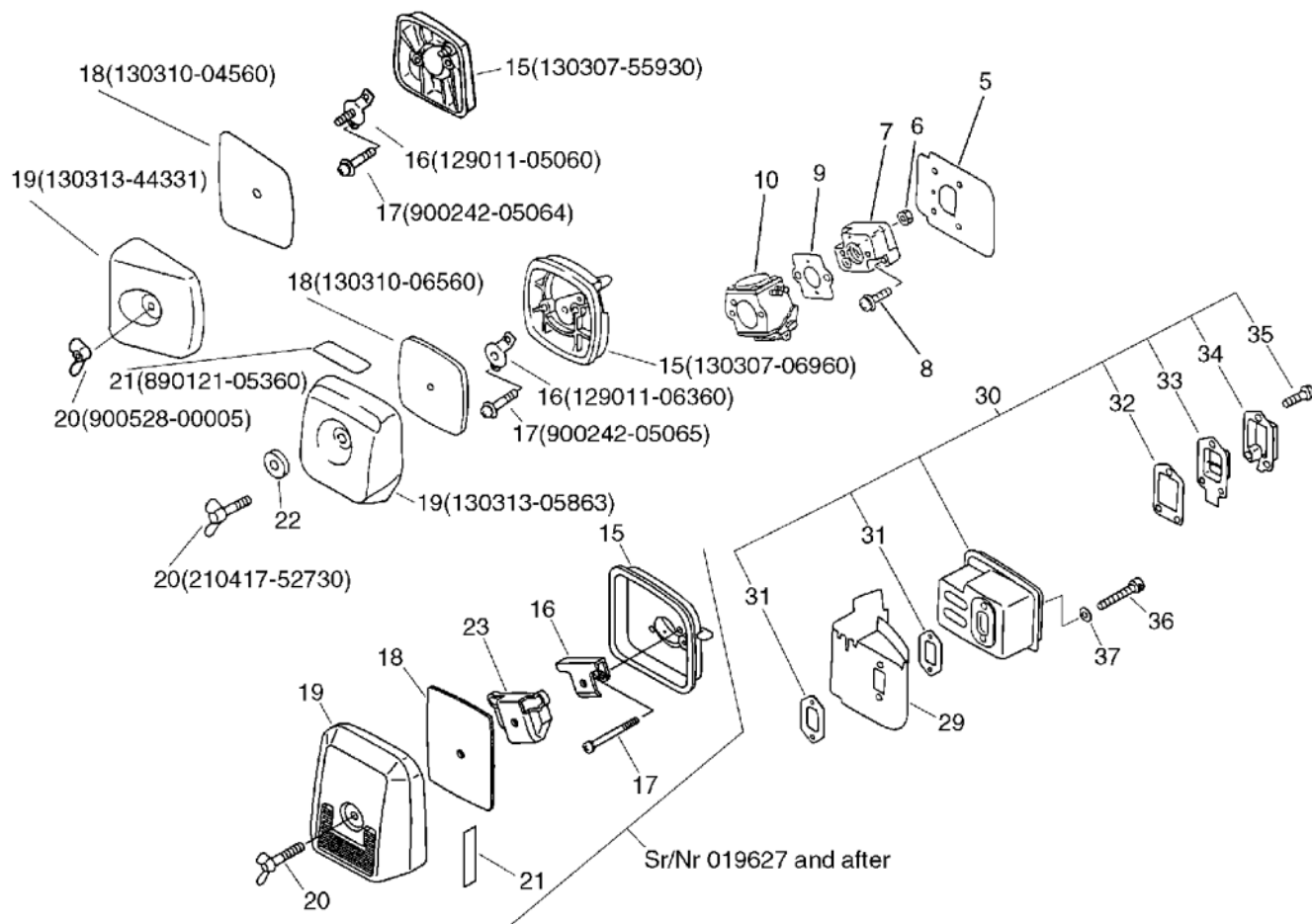

KEY	LV	PART NUMBER	Q'TY	DESCRIPTION	REMARKS	NOTE1	NOTE2
31	+	V104-000160	2	GASKET,EXHAUST			
32	+	145866-42031	1	GASKET, MUFFLER LID			
33	+	145876-42030	1	LID, MUFFLER (B)			
34	+	145863-06960	1	FIXTURE, SCREEN			
35	+	900242-04010	3	SCREW 4*10	4*10		
36		900105-05055	2	BOLT, H.S. 5*55	5*55		
37		900600-00005	2	WASHER 5	5		

4. Fuel Tank

No.4

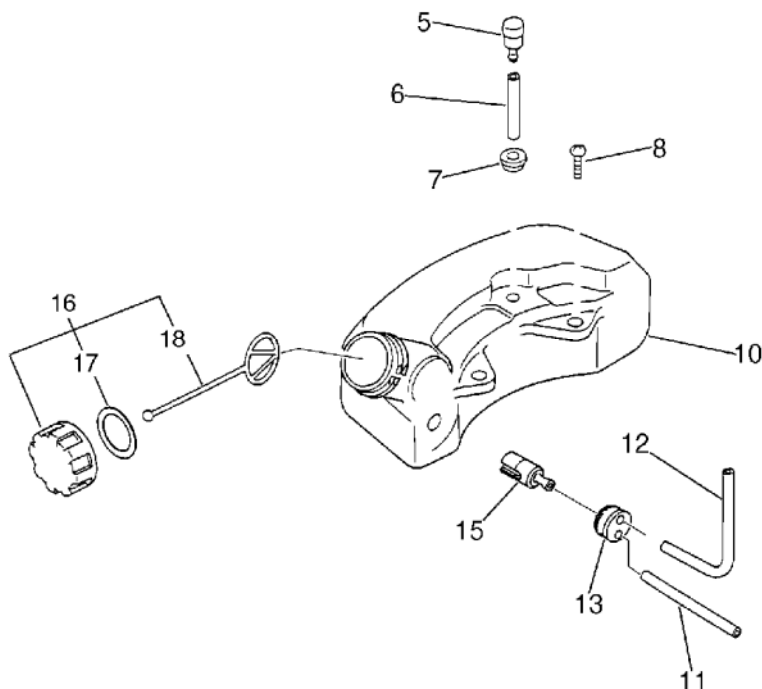

KEY	LV	PART NUMBER	Q'TY	DESCRIPTION	REMARKS	NOTE1	NOTE2
5		131300-49930	1	VALVE, CHECK		Sus. by 131300-56430	
5		131300-56430	1	VALVE, CHECK			
6		132010-21160	1	PIPE, FUEL	3*6*35	Sus. by V471-001180	
6		V471-001180	1	PIPE	3*6*35 NBR		
7		132115-01461	1	GROMMET			
8		900243-05016	2	SCREW 5*16	5*16		
10		131002-08960	1	TANK, FUEL		Sus. by 131002-08961	
10		131002-08961	1	TANK, FUEL			
11		132717-06460	1	PIPE 3*5*110	3*5*110	Sus. by 132010-06460	
11		132010-06460	1	PIPE 3*6*110	3*6*110 YL		
12		132010-02160	1	PIPE, FUEL (INNER)	L=190		
13		132115-44330	1	GROMMET			
15		131205-50430	1	STRAINER, FUEL		Sus. by 131205-07320	
15		131205-07320	1	STRAINER, FUEL			
16		131004-46730	1	CAP ASSY, FUEL TANK		Sus. by 131004-08960	
16		131004-08960	1	CAP ASSY, FUEL			
17	+	131016-40630	1	GASKET, FUEL CAP		Can be used on 131004-46730	

4. Fuel Tank

No.4

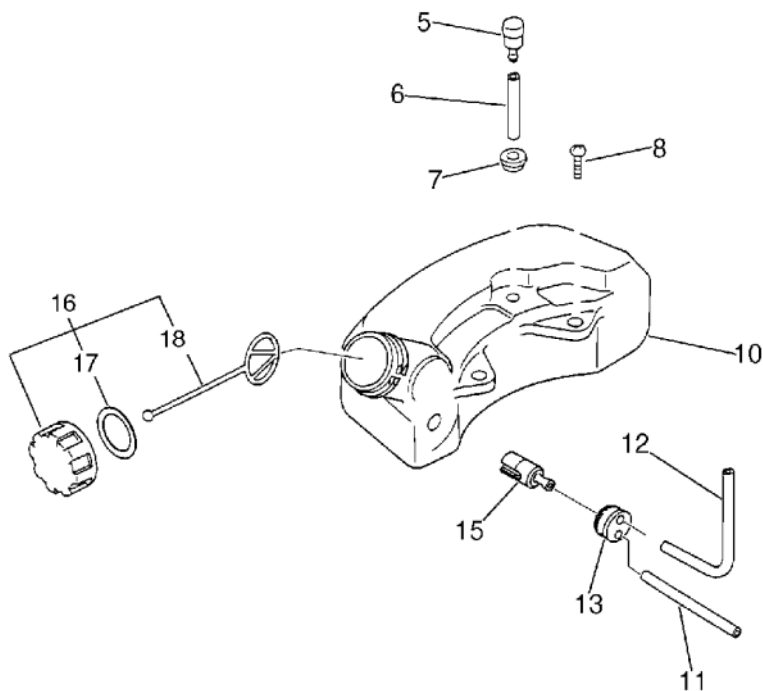

KEY	LV	PART NUMBER	Q'TY	DESCRIPTION	REMARKS	NOTE1	NOTE2
17	+	131016-55830	1	GASKET, FUEL CAP		Can be used on 131004-08960	
18	+	131051-52430	1	CONNECTOR, CAP	80L		

5. Carburetor

No.5

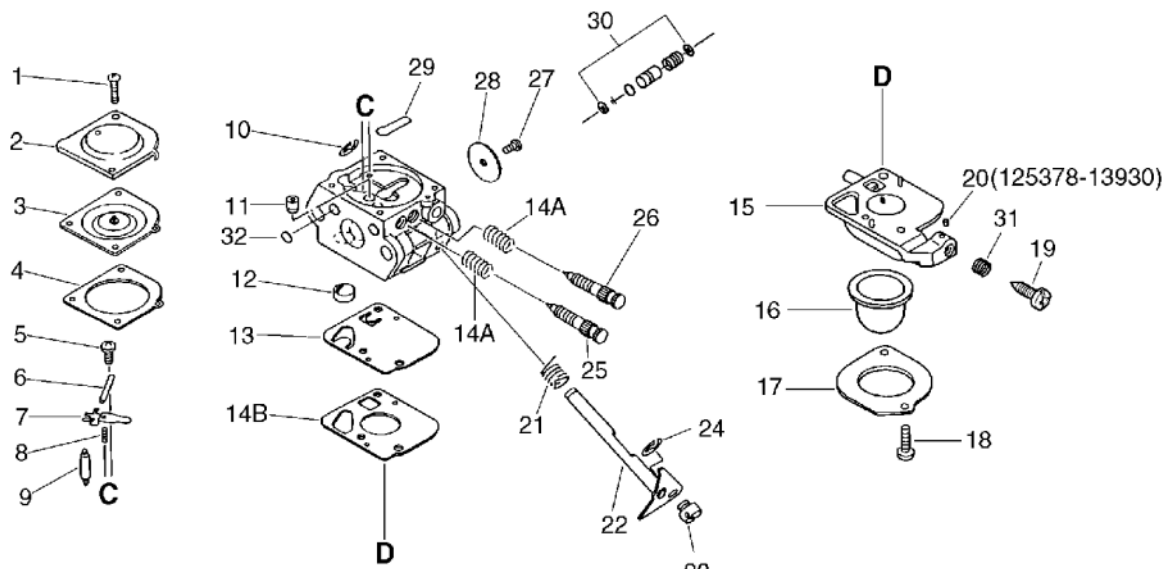

A:125303-13310(3,4,13,14)
 B:125300-13310(3,4,6,7,8,9,12,13,14,29)

KEY	LV	PART NUMBER	Q'TY	DESCRIPTION	REMARKS	NOTE1	NOTE2
		125200-06961	1	CARBURETOR ASSY	C1U-K18	Sus. by 125200-05964	
		125200-06962	1	CARBURETOR ASSY	C1U-K18A	Sus. by 125200-05964	
		125200-05961	1	CARBURETOR C1U-K51	C1U-K51	Sus. by 125200-05964	
		125200-05962	1	CARBURETOR	C1U-K51	Sus. by 125200-05964	
		125200-05963	1	CARBURETOR C1U-K51	C1U-K51	Sus. by 125200-05964	
		125200-05964	1	CARBURETOR	C1U-K51		
1	+	125344-52130	2	SCREW			
2	+	125342-52130	1	COVER, DIAPHRAGM			
3	+	125341-42030	1	DIAPHRAGM		Sr/Nr 010916 and before	
3	+	125341-49030	1	DIAPHRAGM		Sr/Nr 010917 and after	
4	+	125340-51030	1	GASKET, DIAPHRAGM			
5	+	125339-42030	1	SCREW			
6	+	125338-13930	1	PIN, METERING ARM			
7	+	125323-42030	1	LEVER, METERING			
8	+	125322-07260	1	SPRING, COIL		Sr/Nr 010916 and before	
8	+	125322-42030	1	SPRING, COIL		Sr/Nr 010917 and after	
9	+	125337-06960	1	VALVE, INLET NEEDLE			

5. Carburetor

No.5

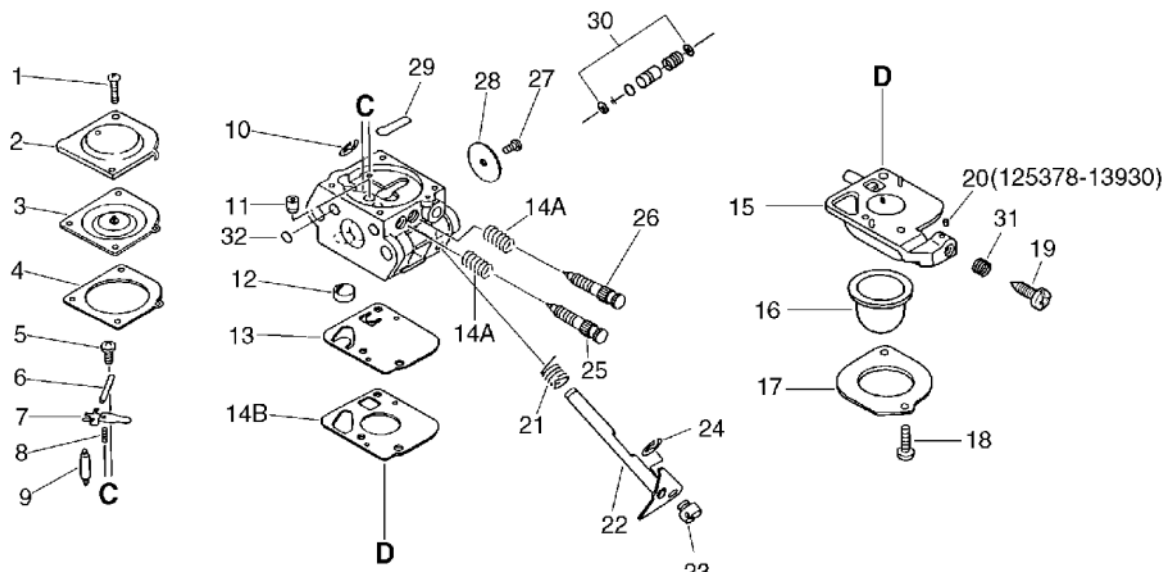

A:125303-13310(3,4,13,14)
 B:125300-13310(3,4,6,7,8,9,12,13,14,29)

KEY	LV	PART NUMBER	Q'TY	DESCRIPTION	REMARKS	NOTE1	NOTE2
10	+	125327-15130	1	CLIP			
11	+	125376-13120	1	NOZZLE, CHECK VALVE			
12	+	125326-42030	1	STRAINER			
13	+	125312-42030	1	DIAPHRAGM, FUEL PUMP		Sr/Nr 010916 and before	
13	+	125312-12820	1	DIAPHRAGM, FUEL PUMP		Sr/Nr 010917 and after	
14A	+	125319-42030	1	SPRING, COIL		Sr/Nr 010916 and before	
14B	+	125325-42030	1	GASKET, FUEL PUMP		Sr/Nr 010916 and before	
14B	+	125325-13310	1	GASKET, PUMP		Sr/Nr 010917 and after	
15	+	125324-11610	1	COVER, PUMP		Sr/Nr 010916 and before	
15	+	125383-13310	1	BASE, PRIMER		Sus. by P005-000590	
15	+	P005-000590	1	BASE,ASY PRIMER		Sr/Nr 010917 and after	
16	+	125381-46730	1	PUMP, PRIMING		Sr/Nr 010916 and before	
16	+	125381-08660	1	PUMP, PRIMING		Sr/Nr 010917 and after	
17	+	125363-11610	1	RING			
18	+	125310-11610	2	SCREW			

5. Carburetor

No.5

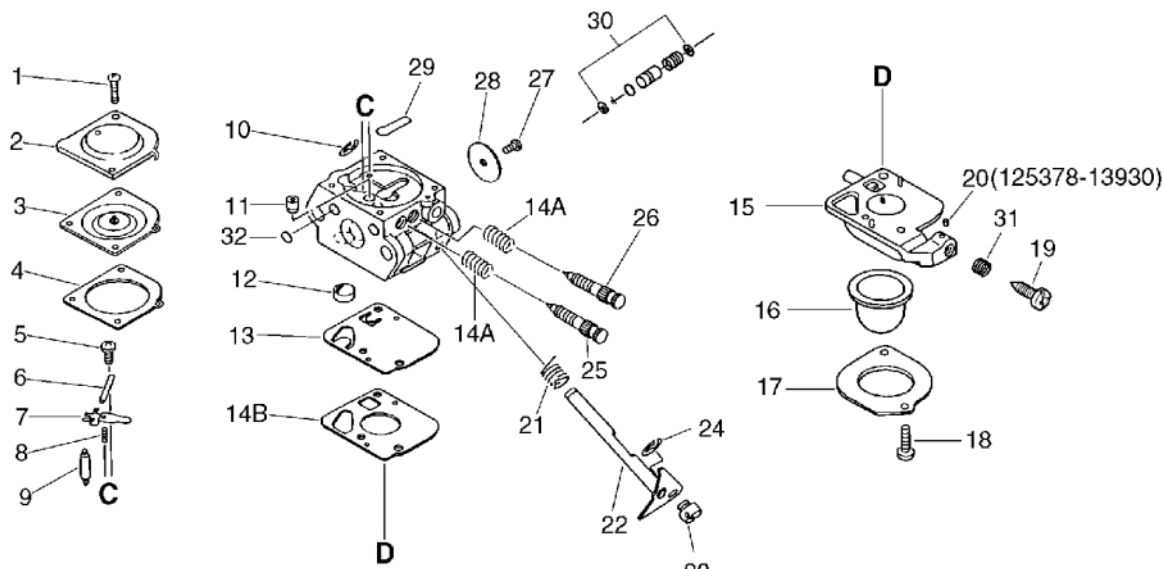

A:125303-13310(3,4,13,14)
 B:125300-13310(3,4,6,7,8,9,12,13,14,29)

KEY	LV	PART NUMBER	Q'TY	DESCRIPTION	REMARKS	NOTE1	NOTE2
19	+	125334-13930	1	SCREW, IDLE ADJUST		Sr/Nr 016476 and before	
19	+	125334-06960	1	SCREW, THROTTLE ADJUST		Sr/Nr 016477 and after	
20	+	125378-13930	1	PIECE, FRICTION		Sr/Nr 016476 and before	
21	+	125313-42030	1	SPRING, THRT. RETURN			
22	+	125317-42030	1	SHAFT, THROTTLE		Sr/Nr 010916 and before	
22	+	125317-13310	1	SHAFT, THROTTLE		Sr/Nr 010917 and after	
23	+	125372-42030	1	SWIVEL			
24	+	125327-13930	1	CLIP			
25	+	125320-07260	1	NEEDLE, HIGH SPEED		Sr/Nr 010916 and before	
25	+	125320-13310	1	NEEDLE, HIGH SPEED		Sr/Nr 010917 and after	
26	+	125318-42030	1	NEEDLE, IDLE		Sr/Nr 010916 and before	
26	+	125318-13310	1	SCREW, IDLE NEEDLE		Sr/Nr 010917 to 011526	
26	+	125318-13120	1	SCREW, IDLE NEEDLE		Sr/Nr 011527 and after	
27	+	125314-13930	1	SCREW	3*4		
28	+	125316-07260	1	VALVE, THROTTLE		Sr/Nr 010916 and before	

5. Carburetor

No.5

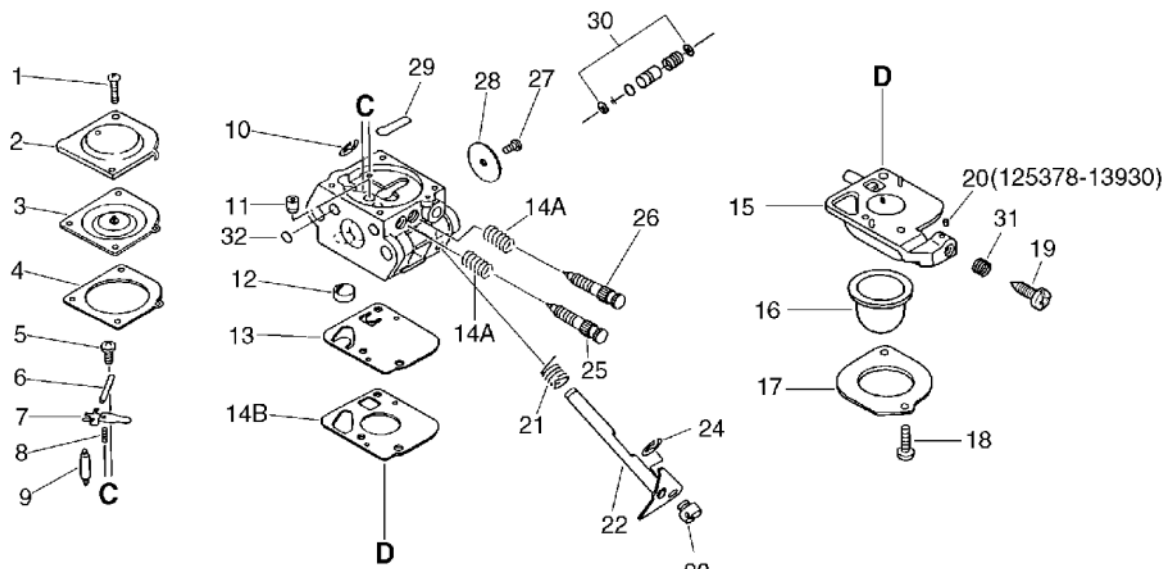

A:125303-13310(3,4,13,14)

B:125300-13310(3,4,6,7,8,9,12,13,14,29)

KEY	LV	PART NUMBER	Q'TY	DESCRIPTION	REMARKS	NOTE1	NOTE2
28	+	125316-49030	1	VALVE, THROTTLE		Sr/Nr 010917 and after	
29	+	125345-15130	1	PLUG, WELCH			
30	+	125306-13120	1	PUMP KIT, ACC.		Sr/Nr 010917 and after	
31	+	125333-06960	1	SPRING, IDLE ADJUSTER		Sr/Nr 016477 and after	
32	+	125345-13310	1	PLUG, WELCH			
A		125303-13310	1	DIAPHRAGM/GASKET KIT			
B		125300-13310	1	REBUILD KIT			

6. Handle

No.6

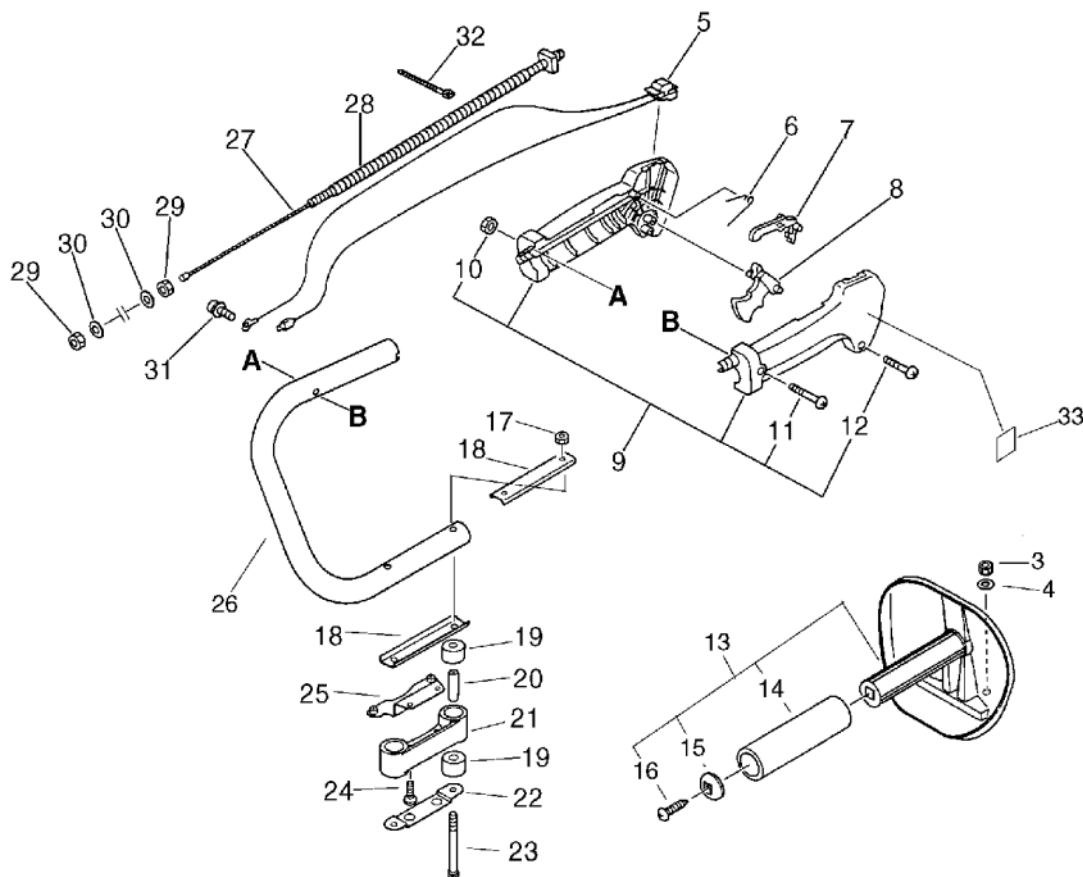

KEY	LV	PART NUMBER	Q'TY	DESCRIPTION	REMARKS	NOTE1	NOTE2
3		900560-00006	2	NUT, LOCK	6		
4		900603-00006	2	WASHER 6	6.5*13*1		
5		163400-05960	1	SWITCH, IGNITION			
6		178013-35631	1	SPRING, THR. LOCK			
7		178012-05960	1	LOCKOUT, THROTTLE			
8		178010-05960	1	CONTROL, THROTTLE			
9		351102-47530	1	GRIP ASSY, F-HANDLE			
10	+	900500-00005	1	NUT 5	5		
11	+	900220-05030	1	SCREW 5*30	5*30		
12	+	900246-03025	4	SCREW 3*25	3*25		
13		351200-07360	1	HANDLE ASSY		Sus. by 351200-07363	
13		351200-07361	1	HANDLE ASY		Sus. by 351200-07363	
13		351200-07362	1	HANDLE ASY		Sus. by 351200-07363	
13		351200-07363	1	HANDLE ASY			
14	+	351012-07360	1	GRIP, HANDLE	22*32*155L	Sus. by 351012-07361	
14	+	351012-07361	1	GRIP, REAR HANDLE			
15	+	351217-07360	1	SUPPORTER, F. HANDLE			
16	+	900253-05014	1	SCREW 5*14	5*14		
17		900560-00005	2	NUT, LOCK 5	5		
18		351243-01260	2	BRACKET			
19		351228-01260	4	CUSHION			
20		351241-01260	2	SPASER			

6. Handle

No.6

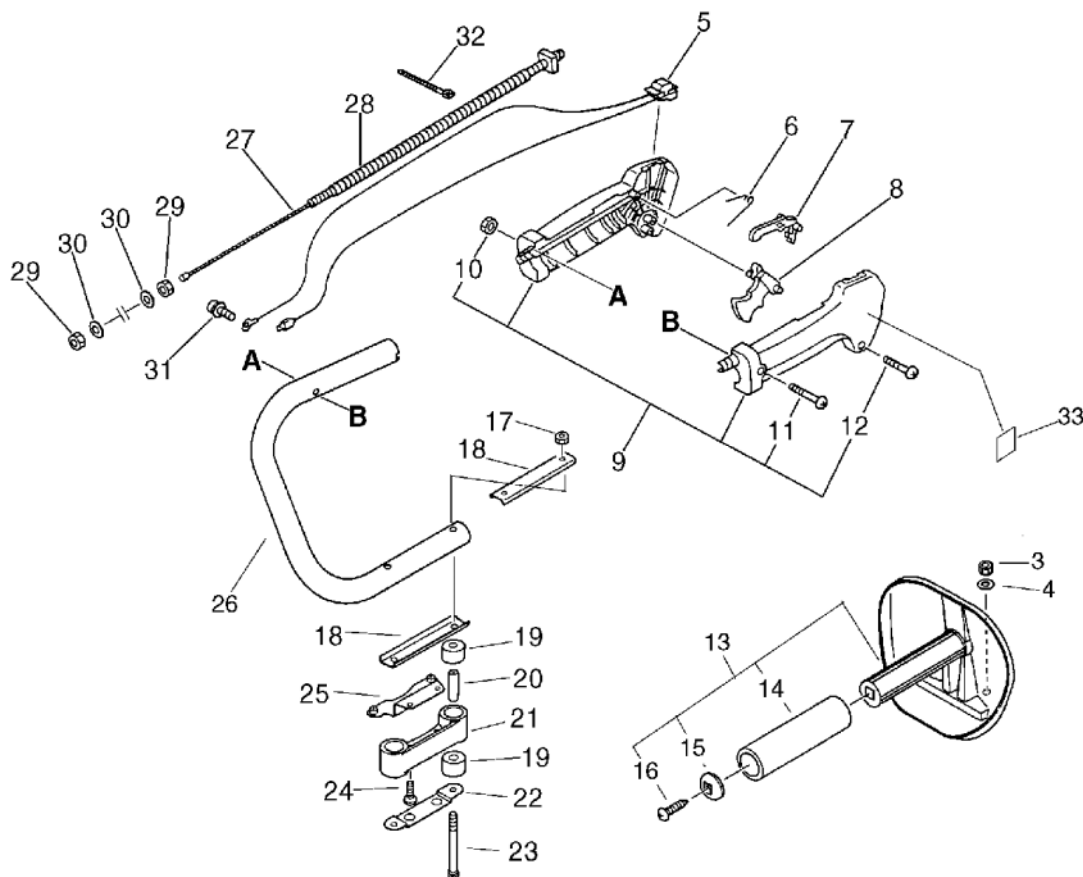

KEY	LV	PART NUMBER	Q'TY	DESCRIPTION	REMARKS	NOTE1	NOTE2
21		351217-05960	1	SUPPORTER, F.HANDLE			
22		351242-01261	1	PLATE			
23		900105-05060	2	BOLT, H.S. 5*60	5*60		
24		900242-05016	2	SCREW 5*16	5*16		
25		610438-01260	1	PLATE			
26		351205-08961	1	HANDLE, REAR			
27		178001-05960	1	WIRE, THROTTLE			
28		178127-05960	1	TUBE	7*330		
29		900502-00006	2	NUT 6 (3N)	3N6		
30		900600-00006	2	WASHER 6	6		
31		900238-05010	1	SCREW 5*10	5*10		
32		178121-10050	1	BAND	CV-150		
33		890157-39130	1	LABEL, SWITCH		Disuse	

7. Gear Case(HC-2300), Cutter, Tools

No.7 (HC-2300)

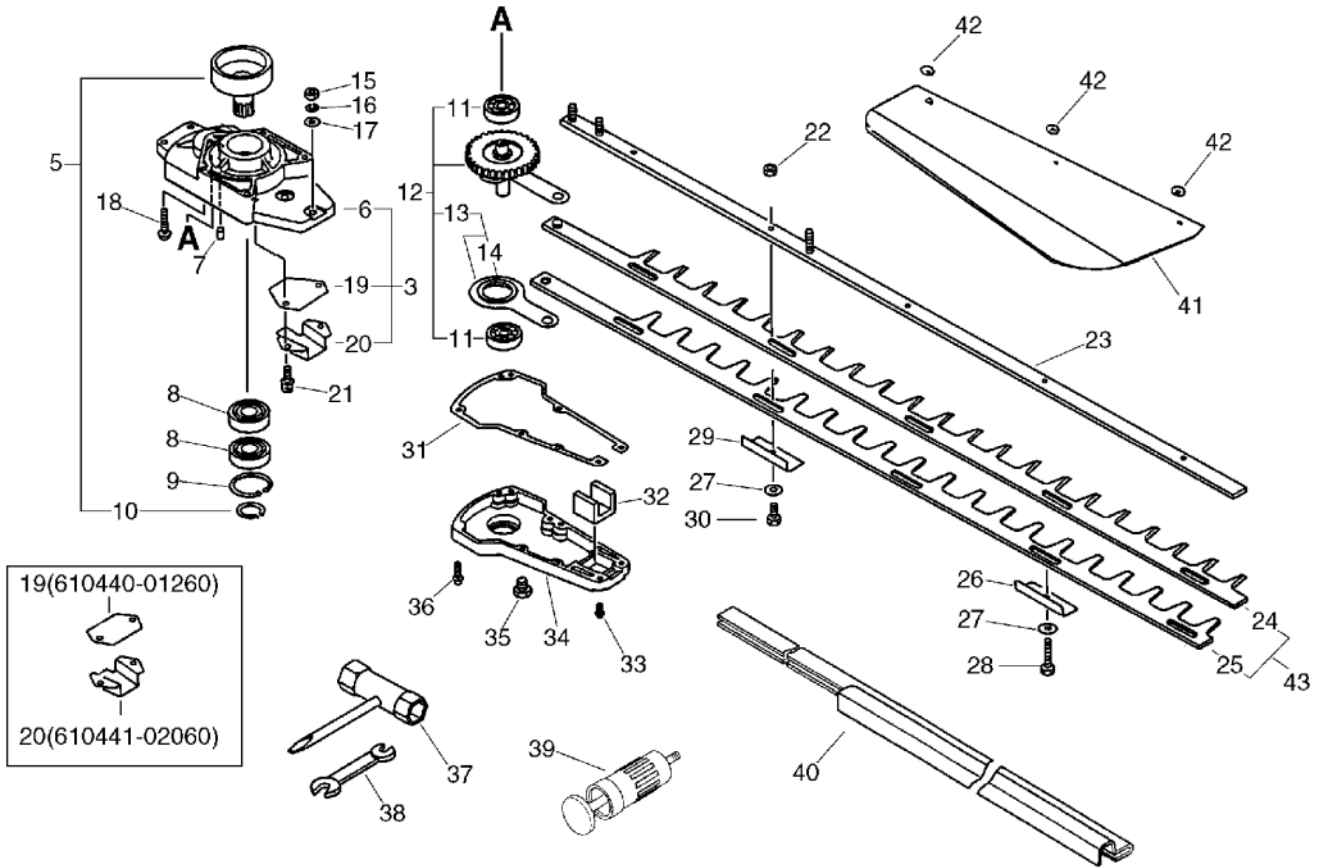

KEY	LV	PART NUMBER	Q'TY	DESCRIPTION	REMARKS	NOTE1	NOTE2
5		175003-01261	1	DRUM W/CLIP, CLUTCH			
10	+	900701-00016	1	CIRCLIP 16	CS-16		
6		610410-05960	1	CASE, GEAR		Sus. by 610406-05961	
3		610406-05960	1	CASE, GEAR		Sus. by 610406-05961	
3		610406-05961	1	CASE, GEAR			
6	+	610410-05961	1	CASE, GEAR		Sus. by 610410-05962	
6	+	610410-05962	1	CASE, GEAR		Added mark "A"	
7	+	100215-03930	1	PIN, DOWEL			
19	+	610440-08960	1	GUIDE,CUTTER		Current	
20	+	610441-08960	1	GUIDE,CUUTER		Current	
8		900802-06003	2	BEARING, BALL 6003	6003DDU(LLU)		
9		900702-00035	1	CIRCLIP 35	CR-35		
12		610302-01260	1	GEAR ASS'Y		Sus. by 610302-01261	
12		610302-01261	1	GEAR ASY			
11	+	900810-06200	2	BEARING, BALL 6200	6200		
13	+	610307-01260	1	CON-ROD ASS'Y		Sus. by 610307-01261	
13	+	610307-01261	1	ROD, CONNECTING			
14	++	610327-01260	1	BEARING, NEEDLE		Sus. by 610327-01261	
14	++	610327-01261	1	BEARING, NEEDLE			

7. Gear Case(HC-2300), Cutter, Tools

No.7 (HC-2300)

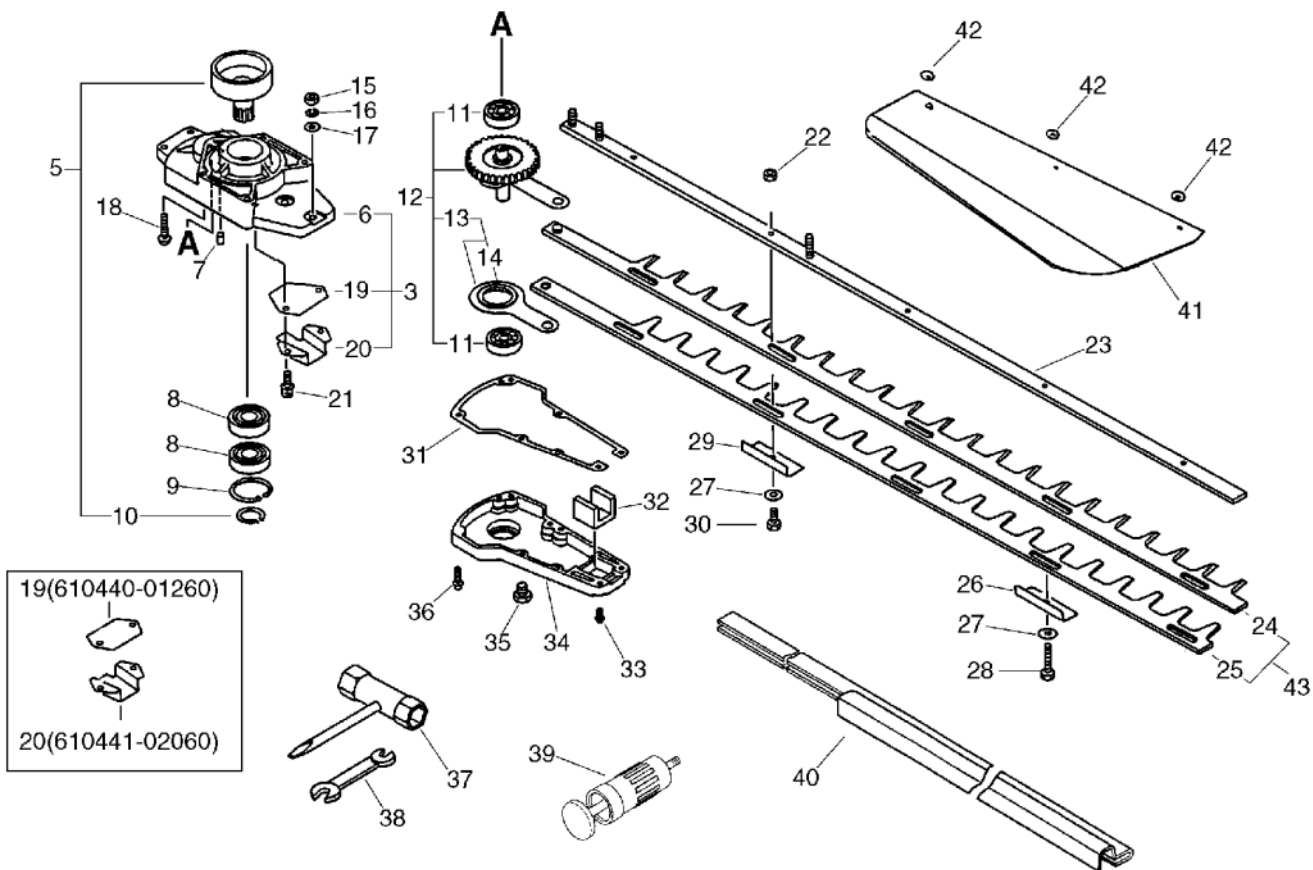

KEY	LV	PART NUMBER	Q'TY	DESCRIPTION	REMARKS	NOTE1	NOTE2
15		900500-00006	2	NUT 6	6		
16		900605-00006	2	WASHER, SPRING 6	6		
17		900600-00006	2	WASHER 6	6		
18		900242-05030	4	SCREW 5*30	5*30		
19		610440-01260	1	GUIDE		Former	
20		610441-02060	1	GUIDE		Former	
21		900162-05014	2	BOLT, H.S. 5*14	5*14 W,SW		
22		900560-00006	4	NUT, LOCK	6		
23		699105-02061	1	BAR, FRAME		Sus. by X425-000100	
23		699110-02062	1	SUPPORT, CUTTER		Sus. by X425-000100	
23		X425-000100	1	SUPPORT, CUTTER			
43		697000-02060	1	CUTTER SET			
24	+	697010-02060	1	CUTTER (UPPER)			
25	+	697011-02060	1	CUTTER (LOWER)			
26		699213-04160	4	INSULATOR			
27		699118-04160	5	WASHER			
28		699115-04160	4	BOLT			
29		699213-02062	1	INSULATOR		Sus. by 699213-02063	
29		699213-02063	1	INSULATOR			
30		351027-02060	1	BOLT			
31		610414-01260	1	GASKET, GEAR HOUSING			
32		610426-01260	1	SEAL			
33		900242-04014	4	SCREW 4*14	4*14		

7. Gear Case(HC-2300), Cutter, Tools

No.7 (HC-2300)

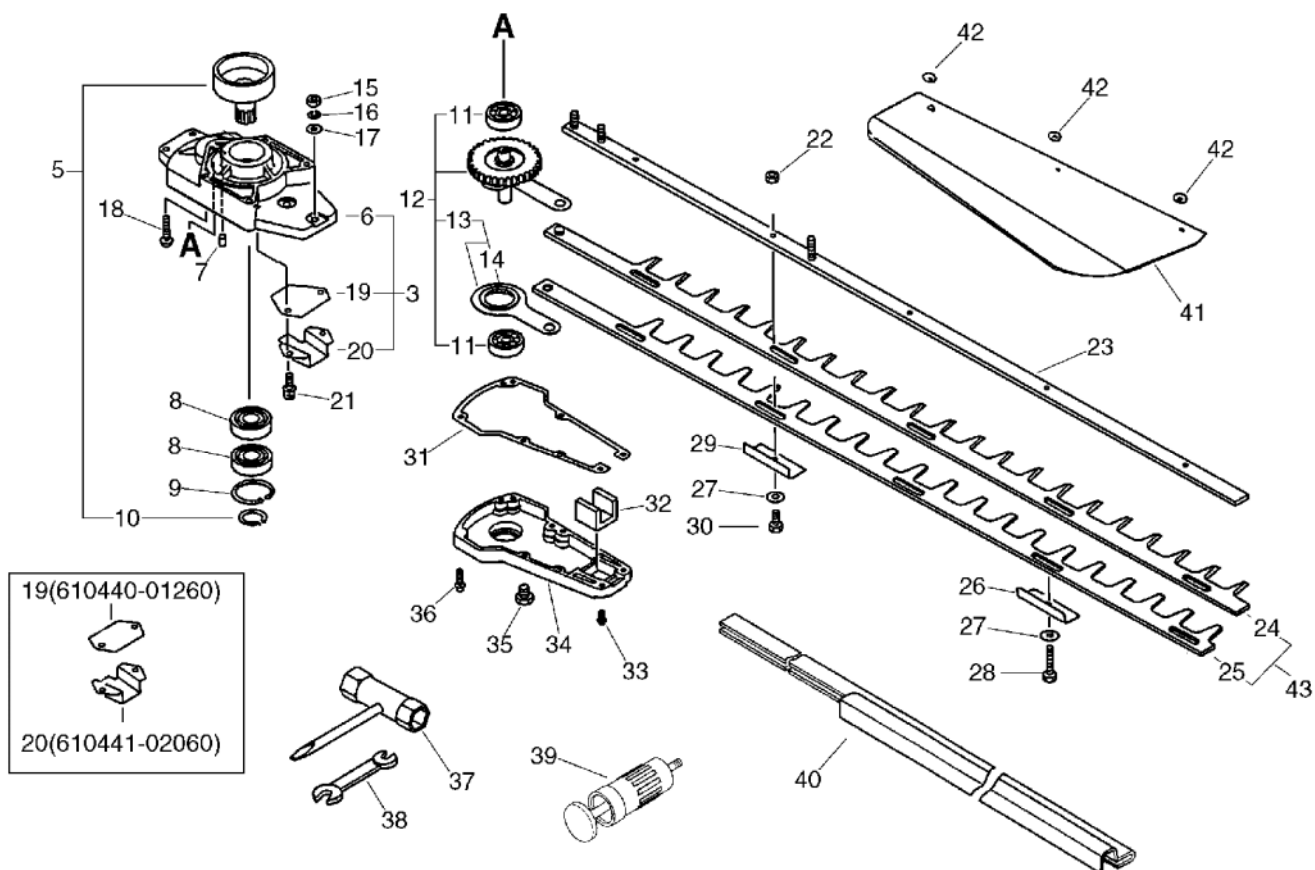

KEY	LV	PART NUMBER	Q'TY	DESCRIPTION	REMARKS	NOTE1	NOTE2
34		610411-05960	1	LID,GEARE CASE		Sus. by 610411-05961	
34		610411-05961	1	CASE, GEAR	M8		
35		610434-50030	1	BOLT 8* 6		Sus. by 610434-50031	
35		610434-50031	1	BOLT 8* 8	M8*8		
36		900242-04022	2	SCREW 4*22	4*22		
37		895410-00430	1	WRENCH, W/S. DRIVER			
38		895112-00330	1	SPANNER 8*10			
39		880300-01260	1	PUMP ASS'Y, GREASE			
40		898523-02961	1	COVER, CUTTER			
41		699511-07360	1	GUIDE, CORRECTION			
42		900603-00006	3	WASHER 6	6.5*13*1		

8. Gear Case(HC-2300W), Cutter, Tools

No.8 (HC-2300W)

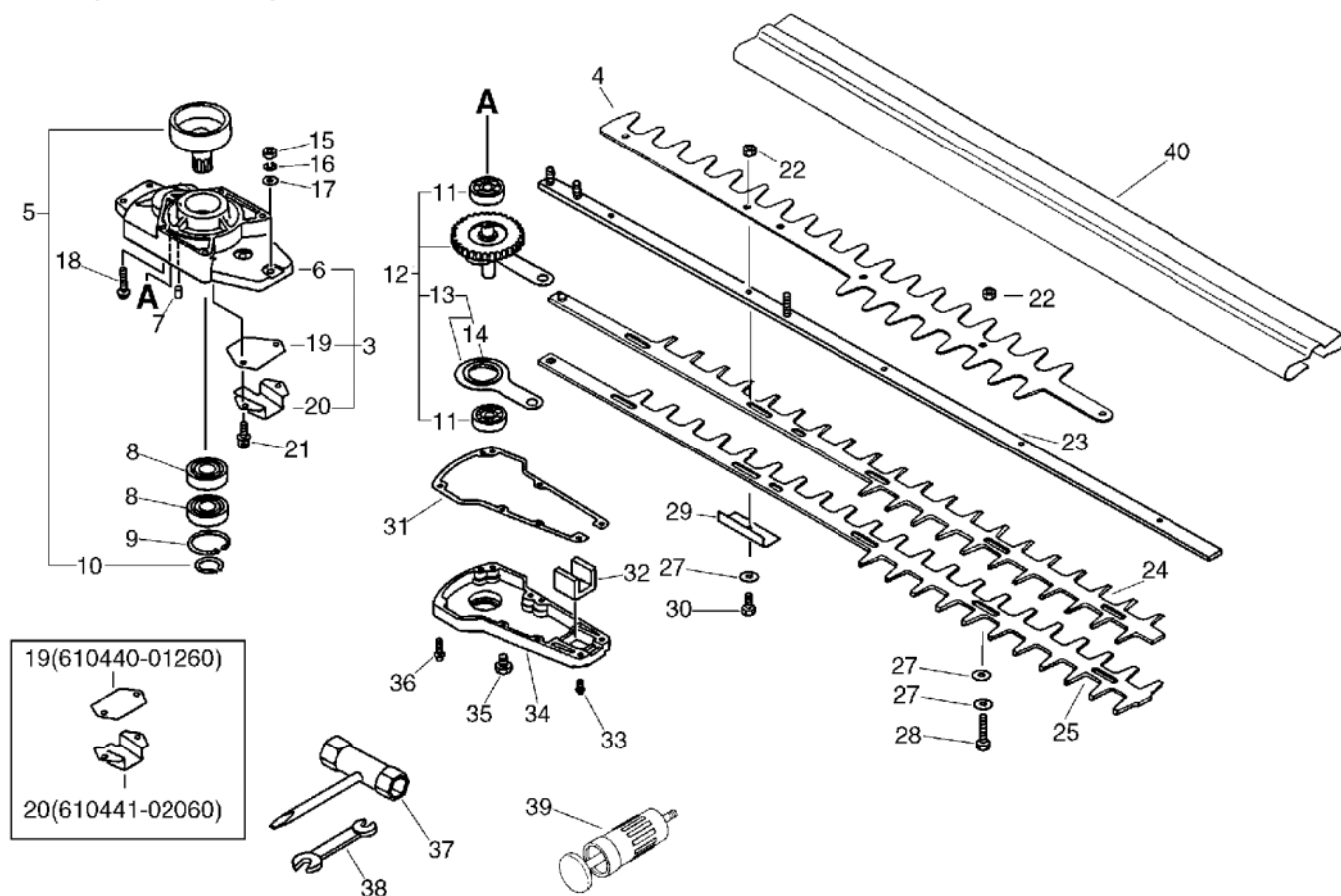

KEY	LV	PART NUMBER	Q'TY	DESCRIPTION	REMARKS	NOTE1	NOTE2
4		699125-07360	1	BLUNT	692L		
5		175003-01261	1	DRUM W/CLIP, CLUTCH			
10	+	900701-00016	1	CIRCLIP 16	CS-16		
6		610410-05960	1	CASE, GEAR		Sus. by 610406-05961	
3		610406-05960	1	CASE, GEAR		Sus. by 610406-05961	
3		610406-05961	1	CASE, GEAR			
6	+	610410-05961	1	CASE, GEAR		Sus. by 610410-05962	
6	+	610410-05962	1	CASE, GEAR		Added mark "A"	
7	+	100215-03930	1	PIN, DOWEL			
19	+	610440-08960	1	GUIDE,CUTTER		Current	
20	+	610441-08960	1	GUIDE,CUUTER		Current	
8		900802-06003	2	BEARING, BALL 6003	6003DDU(LLU)		
9		900702-00035	1	CIRCLIP 35	CR-35		
12		610302-01260	1	GEAR ASS'Y		Sus. by 610302-01261	
12		610302-01261	1	GEAR ASY			
11	+	900810-06200	2	BEARING, BALL 6200	6200		
13	+	610307-01260	1	CON-ROD ASS'Y		Sus. by 610307-01261	
13	+	610307-01261	1	ROD, CONNECTING			
14	++	610327-01260	1	BEARING, NEEDLE		Sus. by 610327-01261	

8. Gear Case(HC-2300W), Cutter, Tools

No.8 (HC-2300W)

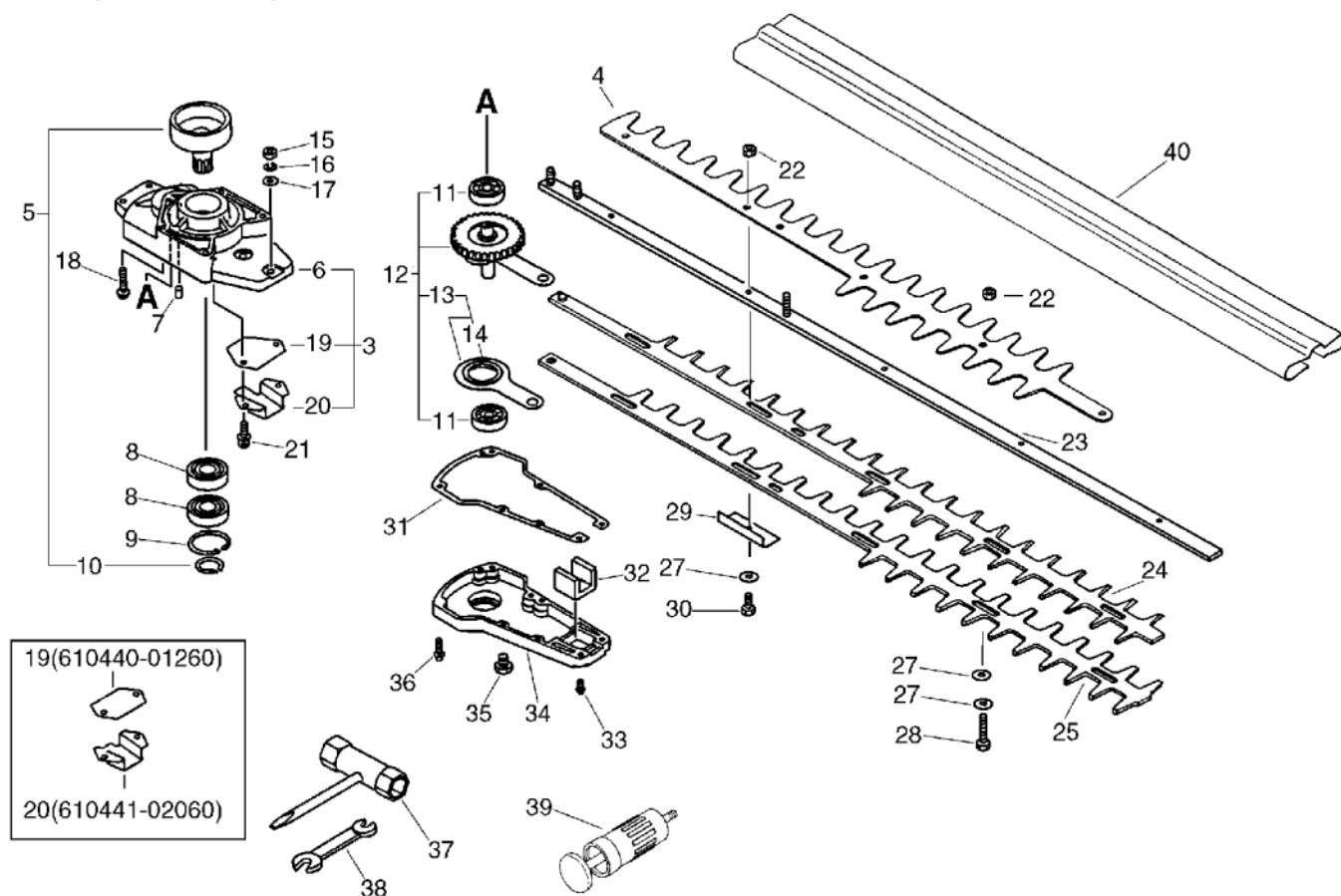

KEY	LV	PART NUMBER	Q'TY	DESCRIPTION	REMARKS	NOTE1	NOTE2
14	++	610327-01261	1	BEARING, NEEDLE			
15		900500-00006	2	NUT 6	6		
16		900605-00006	2	WASHER, SPRING 6	6		
17		900600-00006	2	WASHER 6	6		
18		900242-05030	4	SCREW 5*30	5*30		
19		610440-01260	1	GUIDE		Former	
20		610441-02060	1	GUIDE		Former	
21		900162-05014	2	BOLT, H.S. 5*14	5*14 W,SW		
22		900560-00006	4	NUT, LOCK	6		
23		699105-02061	1	BAR, FRAME		Sus. by X425-000100	
23		699110-02062	1	SUPPORT, CUTTER		Sus. by X425-000100	
23		X425-000100	1	SUPPORT, CUTTER			
24		697010-07360	1	CUTTER		Sus. by 697010-07361	
24		697010-07361	1	CUTTER			
25		697011-07360	1	CUTTER		Sus. by 697011-07361	
25		697011-07361	1	CUTTER			
27		699118-04160	9	WASHER			
28		699115-04160	4	BOLT			
29		699213-02062	1	INSULATOR		Sus. by 699213-02063	
29		699213-02063	1	INSULATOR			
30		351027-02060	1	BOLT			

8. Gear Case(HC-2300W), Cutter, Tools

No.8 (HC-2300W)

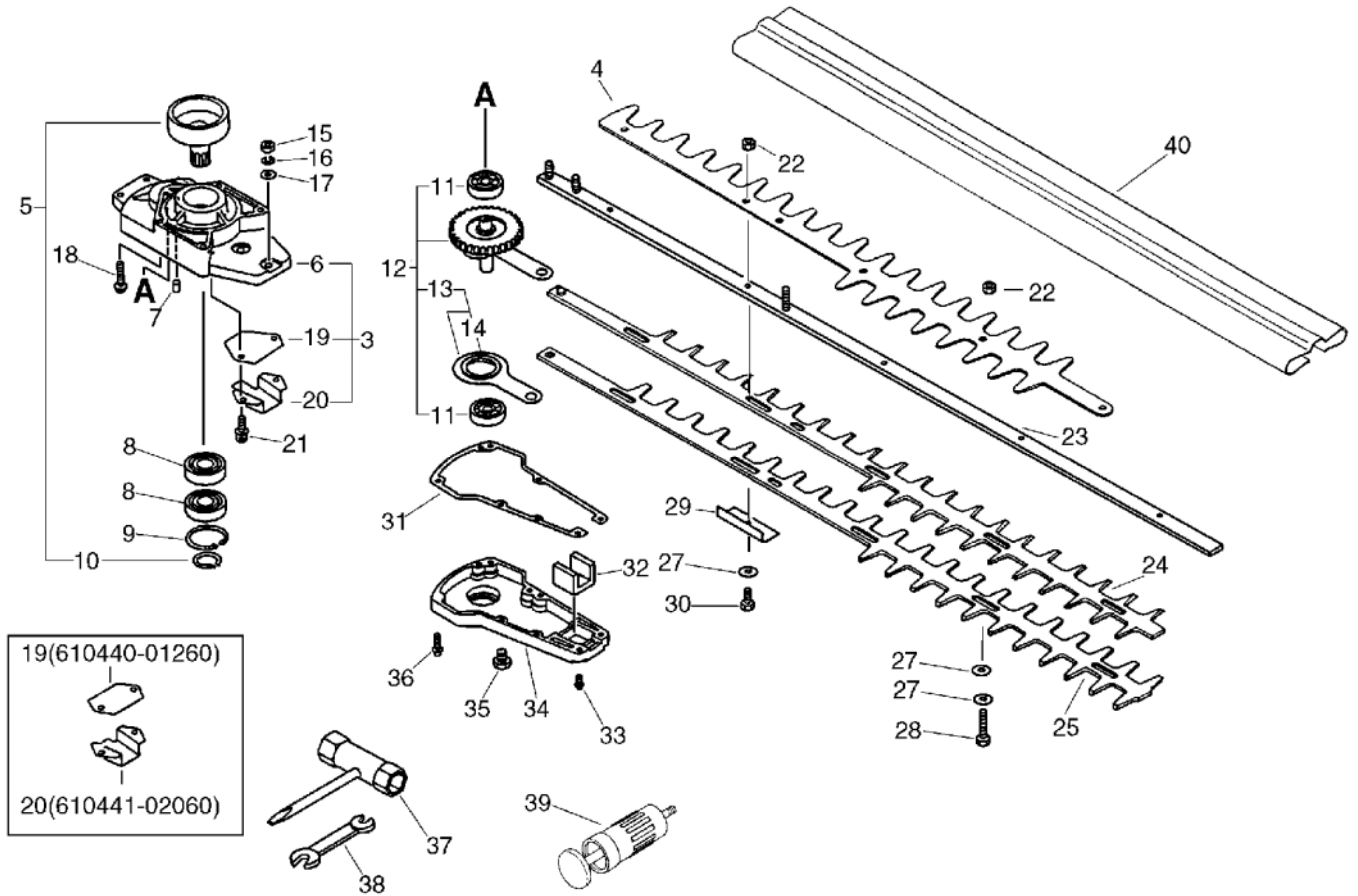

KEY	LV	PART NUMBER	Q'TY	DESCRIPTION	REMARKS	NOTE1	NOTE2
31		610414-01260	1	GASKET, GEAR HOUSING			
32		610426-01260	1	SEAL			
33		900242-04014	4	SCREW 4*14	4*14		
34		610411-05960	1	LID,GEARE CASE		Sus. by 610411-05961	
34		610411-05961	1	CASE, GEAR	M8		
35		610434-50030	1	BOLT 8* 6		Sus. by 610434-50031	
35		610434-50031	1	BOLT 8* 8	M8*8		
36		900242-04022	2	SCREW 4*22	4*22		
37		895410-00430	1	WRENCH, W/S. DRIVER			
38		895112-00330	1	SPANNER 8*10			
39		880300-01260	1	PUMP ASS'Y, GREASE			
40		898523-05160	1	COVER, CUTTER			

Index

Patrs Number	Key No.	Patrs Number	Key No.	Patrs Number	Key No.
100000-44330	1 - 14	125320-07260	5 - 25	130313-44331	3 - 19
100000-44331	1 - 14	125320-13310	5 - 25	130422-09660	3 - 16
100011-05330	1 - 17	125322-07260	5 - 8	131002-08960	4 - 10
100012-51230	1 - 4	125322-42030	5 - 8	131002-08961	4 - 10
100013-11520	1 - 16	125323-42030	5 - 7	131004-08960	4 - 16
100014-11520	1 - 13	125324-11610	5 - 15	131004-46730	4 - 16
100015-04630	1 - 15	125325-13310	5 - 14B	131016-40630	4 - 17
100100-05962	1 - 10	125325-42030	5 - 14B	131016-55830	4 - 17
100100-05963	1 - 10	125326-42030	5 - 12	131051-52430	4 - 18
100204-51030	1 - 7	125327-13930	5 - 24	131205-07320	4 - 15
100204-51031	1 - 7	125327-15130	5 - 10	131205-50430	4 - 15
100212-42030	1 - 5	125333-06960	5 - 31	131300-49930	4 - 5
100212-42031	1 - 5	125334-06960	5 - 19	131300-56430	4 - 5
100215-03930	1 - 8	125334-13930	5 - 19	131920-28230	2 - 46
100215-03930	7 - 7	125337-06960	5 - 9	132010-02160	4 - 12
100215-03930	8 - 7	125338-13930	5 - 6	132010-06460	4 - 11
100242-42030	1 - 11	125339-42030	5 - 5	132010-21160	4 - 6
101010-44331	1 - 18	125340-51030	5 - 4	132115-01461	4 - 7
101010-44332	1 - 18	125341-42030	5 - 3	132115-44330	4 - 13
101011-45230	1 - 19	125341-49030	5 - 3	132717-06460	4 - 11
101514-05960	1 - 25	125342-52130	5 - 2	145510-42031	3 - 31
125200-05961	3 - 10	125344-52130	5 - 1	145631-42030	3 - 29
125200-05961	5 -	125345-13310	5 - 32	145802-05960	3 - 30
125200-05962	3 - 10	125345-15130	5 - 29	145863-06960	3 - 34
125200-05962	5 -	125363-11610	5 - 17	145866-42031	3 - 32
125200-05963	3 - 10	125372-42030	5 - 23	145871-44331	3 - 29
125200-05963	5 -	125376-13120	5 - 11	145876-42030	3 - 33
125200-05964	3 - 10	125378-13930	5 - 20	156110-04920	2 - 31
125200-05964	5 -	125381-08660	5 - 16	156601-44730	2 - 25
125200-06961	3 - 10	125381-46730	5 - 16	156601-44731	2 - 25
125200-06961	5 -	125383-13310	5 - 15	156601-52130	2 - 25
125200-06962	3 - 10	129011-05060	3 - 16	156801-12360	2 - 23
125200-06962	5 -	129011-06360	3 - 16	156801-44730	2 - 23
125300-13310	5 - B	129011-09560	3 - 23	156801-44731	2 - 23
125303-13310	5 - A	130010-42032	3 - 5	159011-03432	2 - 29
125306-13120	5 - 30	130016-42031	3 - 9	159012-03433	2 - 30
125310-11610	5 - 18	130017-42031	3 - 7	159017-10230	2 - 28
125312-12820	5 - 13	130307-05360	3 - 15	162010-52830	2 - 26
125312-42030	5 - 13	130307-06960	3 - 15	163400-05960	6 - 5
125313-42030	5 - 21	130307-09660	3 - 15	175000-02962	2 - 45
125314-13930	5 - 27	130307-09661	3 - 15	175003-01261	7 - 5
125316-07260	5 - 28	130307-09662	3 - 15	175003-01261	8 - 5
125316-49030	5 - 28	130307-55930	3 - 15	175009-05131	2 - 43
125317-13310	5 - 22	130310-04560	3 - 18	175014-05360	2 - 40
125317-42030	5 - 22	130310-06560	3 - 18	175016-07330	2 - 44
125318-13120	5 - 26	130310-51830	3 - 18	175018-05960	2 - 42
125318-13310	5 - 26	130313-05862	3 - 19	175019-04920	2 - 41
125318-42030	5 - 26	130313-05863	3 - 19	177200-07162	2 - 7
125319-42030	5 - 14A	130313-09561	3 - 19	177202-07360	2 - 18

Index

Patrs Number	Key No.	Patrs Number	Key No.	Patrs Number	Key No.
177202-07361	2 - 18	610406-05961	8 - 3	699213-04160	7 - 26
177215-05960	2 - 10	610410-05960	7 - 6	699511-07360	7 - 41
177218-44330	2 - 19	610410-05960	8 - 6	880300-01260	7 - 39
177220-42030	2 - 9	610410-05961	7 - 6	880300-01260	8 - 39
177226-05960	2 - 13	610410-05961	8 - 6	890112-07360	2 - 6
177227-42030	2 - 14	610410-05962	7 - 6	890112-07361	2 - 6
177228-06530	2 - 15	610410-05962	8 - 6	890112-07362	2 - 6
177234-05960	2 - 20	610411-05960	7 - 34	890112-07560	2 - 5
177236-44330	2 - 12	610411-05960	8 - 34	890118-49130	2 - 5
178001-05960	6 - 27	610411-05961	7 - 34	890121-05360	3 - 21
178010-05960	6 - 8	610411-05961	8 - 34	890121-09560	3 - 21
178012-05960	6 - 7	610414-01260	7 - 31	890157-39130	6 - 33
178013-35631	6 - 6	610414-01260	8 - 31	890617-07660	2 - 6
178121-10050	6 - 32	610426-01260	7 - 32	895112-00330	7 - 38
178127-05960	6 - 28	610426-01260	8 - 32	895112-00330	8 - 38
210417-09560	3 - 20	610434-50030	7 - 35	895410-00430	7 - 37
210417-52730	3 - 20	610434-50030	8 - 35	895410-00430	8 - 37
351012-07360	6 - 14	610434-50031	7 - 35	898523-02961	7 - 40
351012-07361	6 - 14	610434-50031	8 - 35	898523-05160	8 - 40
351027-02060	7 - 30	610438-01260	6 - 25	900105-05055	3 - 36
351027-02060	8 - 30	610440-01260	7 - 19	900105-05060	6 - 23
351102-47530	6 - 9	610440-01260	8 - 19	900162-05014	7 - 21
351200-07360	6 - 13	610440-08960	7 - 19	900162-05014	8 - 21
351200-07361	6 - 13	610440-08960	8 - 19	900162-05022	1 - 20
351200-07362	6 - 13	610441-02060	7 - 20	900162-05028	1 - 6
351200-07363	6 - 13	610441-02060	8 - 20	900220-05030	6 - 11
351205-08961	6 - 26	610441-08960	7 - 20	900238-04016	2 - 4
351217-05960	6 - 21	610441-08960	8 - 20	900238-04016	2 - 48
351217-07360	6 - 15	610444-28230	3 - 22	900238-04022	1 - 26
351228-01260	6 - 19	697000-02060	7 - 43	900238-04022	2 - 24
351241-01260	6 - 20	697010-02060	7 - 24	900238-05010	6 - 31
351242-01261	6 - 22	697010-07360	8 - 24	900238-05020	3 - 8
351243-01260	6 - 18	697010-07361	8 - 24	900238-05028	1 - 6
610223-05960	2 - 47	697011-02060	7 - 25	900242-04010	3 - 35
610302-01260	7 - 12	697011-07360	8 - 25	900242-04014	7 - 33
610302-01260	8 - 12	697011-07361	8 - 25	900242-04014	8 - 33
610302-01261	7 - 12	699105-02061	7 - 23	900242-04022	7 - 36
610302-01261	8 - 12	699105-02061	8 - 23	900242-04022	8 - 36
610307-01260	7 - 13	699110-02062	7 - 23	900242-05016	6 - 24
610307-01260	8 - 13	699110-02062	8 - 23	900242-05030	7 - 18
610307-01261	7 - 13	699115-04160	7 - 28	900242-05030	8 - 18
610307-01261	8 - 13	699115-04160	8 - 28	900242-05057	3 - 17
610327-01260	7 - 14	699118-04160	7 - 27	900242-05064	3 - 17
610327-01260	8 - 14	699118-04160	8 - 27	900242-05065	3 - 17
610327-01261	7 - 14	699125-07360	8 - 4	900243-05016	4 - 8
610327-01261	8 - 14	699213-02062	7 - 29	900246-03025	6 - 12
610406-05960	7 - 3	699213-02062	8 - 29	900253-05014	6 - 16
610406-05960	8 - 3	699213-02063	7 - 29	900500-00005	3 - 6
610406-05961	7 - 3	699213-02063	8 - 29	900500-00005	6 - 10

Index

Patrs Number	Key No.	Patrs Number	Key No.	Patrs Number	Key No.
900500-00006	7 - 15				
900500-00006	8 - 15				
900502-00006	6 - 29				
900512-00008	2 - 16				
900528-00005	3 - 20				
900560-00005	6 - 17				
900560-00006	6 - 3				
900560-00006	7 - 22				
900560-00006	8 - 22				
900600-00005	3 - 37				
900600-00006	6 - 30				
900600-00006	7 - 17				
900600-00006	8 - 17				
900600-00008	2 - 17				
900603-00006	6 - 4				
900603-00006	7 - 42				
900605-00006	7 - 16				
900605-00006	8 - 16				
900701-00016	7 - 10				
900701-00016	8 - 10				
900702-00035	7 - 9				
900702-00035	8 - 9				
900802-06003	7 - 8				
900802-06003	8 - 8				
900810-06200	7 - 11				
900810-06200	8 - 11				
900810-36201	1 - 9				
94035-36201	1 - 9				
A320-000250	3 - 29				
A320-000251	3 - 29				
P005-000590	5 - 15				
P022-007980	2 - 20				
V104-000160	3 - 31				
V471-001180	4 - 6				
V475-001900	2 - 33				
V553-000010	1 - 4				
V553-000030	1 - 4				
X425-000100	7 - 23				
X425-000100	8 - 23				

YAMABIKO CORPORATION

7-2 SUEHIROCHO 1-CHOME, OHME, TOKYO 198-8760, JAPAN
PHONE: 81-428-32-6118. FAX: 81-428-32-6145.



0(W)
No.