



PARTS CATALOGUE

ELECTRIC HEDGE TRIMMER

DHC-30

1. Gear Case, Cutter

No.1

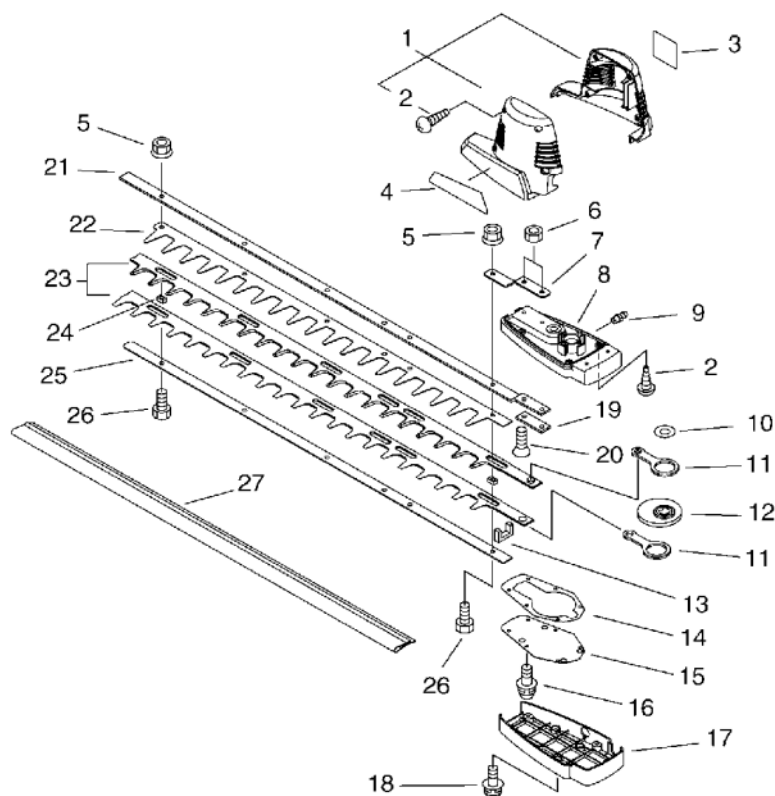

KEY	LV	PART NUMBER	Q'TY	DESCRIPTION	REMARKS	NOTE1	NOTE2
1		P021-010810	1	CASE,MOTOR			
2	+	91604-04022	4	SCREW TAPPING	+BV		
3		X505-002140	1	LABEL,CAUTION			
4		X503-007460	1	LABEL,MODEL	DHC-30		
5		V264-000040	4	NUT,6			
6		91606-06000	2	NUT	N-6		
7		V152-001820	1	PLATE,ANGLE			
8		610410-09961	1	CASE, GEAR			
9		94981-06075	1	NIPPLE, GREASE	A-M6F M6x0.75		
10		610350-04560	1	WASHER			
11		C532-000120	2	ROD, CONNECTING			
12		610312-04560	1	GEAR			
13		610425-04560	1	SEAL			
14		610414-09960	1	GASKET, GEAR HOUSING			
15		610411-09960	1	RID,GEARCASE			
16		91603-04012	4	SCREW	SMB-4*12		
17		660020-09961	1	COVER, GEAR CASE			
18		91603-04016	5	SCREW	SMB-4*16		
19		610440-04560	1	HOLDER, FRAME			
20		91602-06025	2	SCREW	+SF-6*25		
21		X425-000330	1	SUPPORT,CUTTER			
22		E278-000010	1	PROTECTOR			
23		P021-010820	1	CUTTER			
24		V376-000890	6	SPACER			
25		X425-000340	1	SUPPORT,CUTTER			

1. Gear Case, Cutter

No.1

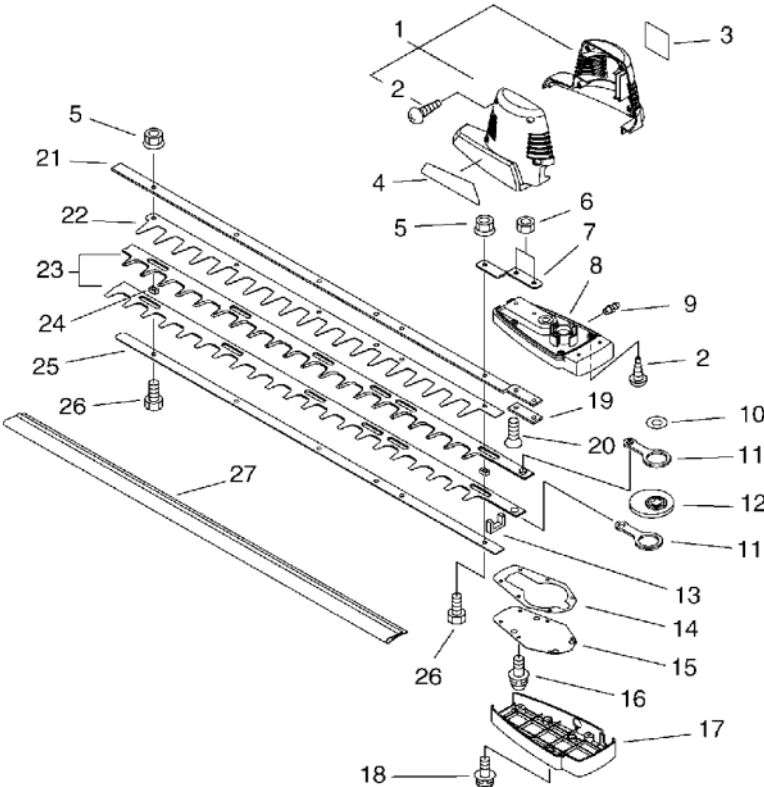

KEY	LV	PART NUMBER	Q'TY	DESCRIPTION	REMARKS	NOTE1	NOTE2
26		V204-000180	4	BOLT,6	6*20		
27		X495-000090	1	SCABBARD,BLADE			

2. Handle

No.2

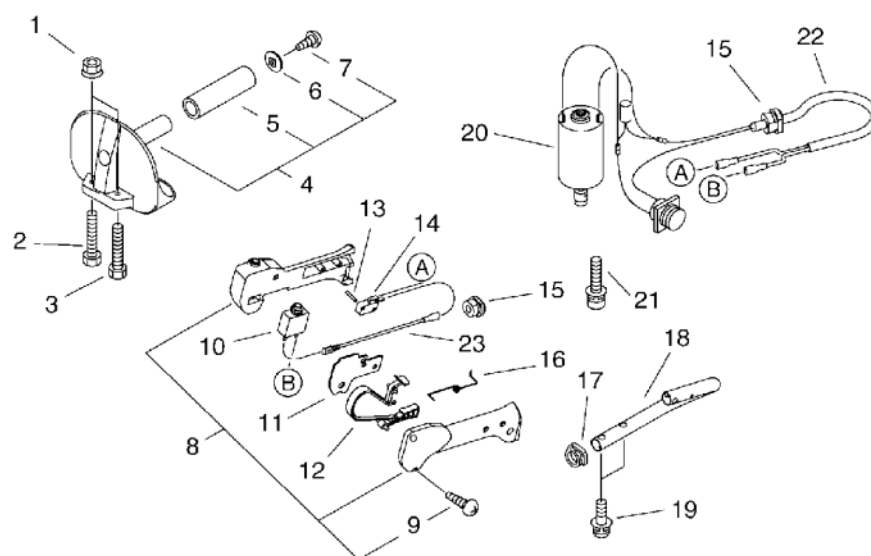

KEY	LV	PART NUMBER	Q'TY	DESCRIPTION	REMARKS	NOTE1	NOTE2
1		V264-000040	2	NUT,6			
2		V204-000170	1	BOLT,6	6*35		
3		V204-000190	1	BOLT,6	6*30		
4		P021-010830	1	HANDLE,FRONT			
5	+	351012-09961	1	GRIP, HANDLE	22*40*109		
6	+	351217-07361	1	SUPPORTER, F. HANDLE			
7	+	91605-05014	1	SCREW TAPPING	+		
8		P021-010840	1	GRIP,HANDLE			
9	+	91604-04022	4	SCREW TAPPING	+BV		
10		C137-000020	1	PROTECTOR, CIRCUIT			
11		163925-09960	1	PLATE, PARTITION			
12		178010-09961	1	CONTROL, THROTTLE			
13		100924-09960	2	PIN, STRAIGHT			
14		A440-000720	1	SWITCH, ON OFF			
15		163915-09960	2	GROMMET, CABLE			
16		163311-09960	1	SPRING			
17		159112-09961	1	CLIP			
18		P021-010850	1	HANDLE,REAR			
19	+	91603-05025	2	SCREW	SMB-5*25		
20		P021-011020	1	MOTOR ASY			
21		900162-05030	2	BOLT, H.S. 5*30	5*30 W,SW		
22		C130-000130	1	HARNESS, WIRE			
23		162010-09960	1	LEAD			

3. Battery Case

No.3

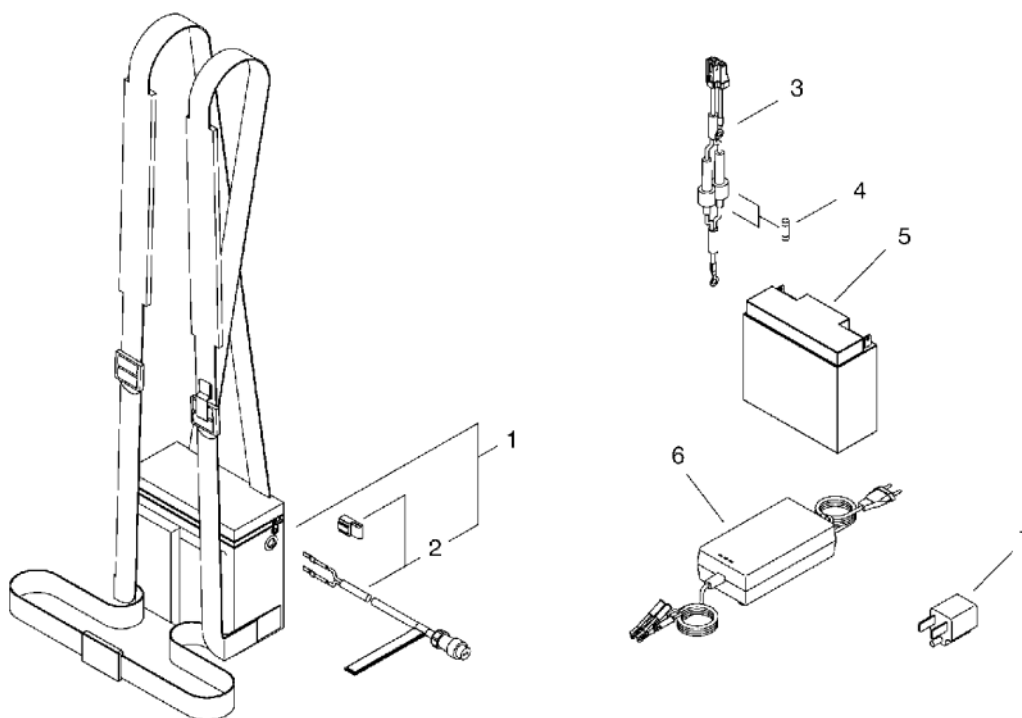

KEY	LV	PART NUMBER	Q'TY	DESCRIPTION	REMARKS	NOTE1	NOTE2
1		P021-010860	1	BATTERY CASE ASM			
2	+	P021-010870	1	HARNESS,WIRE			
3		G306-000220	1	CABLE,BATTERY			
4		P022-003360	2	FUSE	DC32V-30A		
5		V481-000080	1	BATTERY	GT12-18		
6		A046-000030	1	CHARGER	C1205 ROHS		
7		C152-000370	1	CONNECTOR	3PIN BF		

Index

Patrs Number	Key No.	Patrs Number	Key No.	Patrs Number	Key No.
100924-09960	2 - 13	V264-000040	2 - 1		
159112-09961	2 - 17	V376-000890	1 - 24		
162010-09960	2 - 23	V481-000080	3 - 5		
163311-09960	2 - 16	X425-000330	1 - 21		
163915-09960	2 - 15	X425-000340	1 - 25		
163925-09960	2 - 11	X495-000090	1 - 27		
178010-09961	2 - 12	X503-007460	1 - 4		
351012-09961	2 - 5	X505-002140	1 - 3		
351217-07361	2 - 6				
610312-04560	1 - 12				
610350-04560	1 - 10				
610410-09961	1 - 8				
610411-09960	1 - 15				
610414-09960	1 - 14				
610425-04560	1 - 13				
610440-04560	1 - 19				
660020-09961	1 - 17				
900162-05030	2 - 21				
91602-06025	1 - 20				
91603-04012	1 - 16				
91603-04016	1 - 18				
91603-05025	2 - 19				
91604-04022	1 - 2				
91604-04022	2 - 9				
91605-05014	2 - 7				
91606-06000	1 - 6				
94981-06075	1 - 9				
A046-000030	3 - 6				
A440-000720	2 - 14				
C130-000130	2 - 22				
C137-000020	2 - 10				
C152-000370	3 - 7				
C532-000120	1 - 11				
E278-000010	1 - 22				
G306-000220	3 - 3				
P021-010810	1 - 1				
P021-010820	1 - 23				
P021-010830	2 - 4				
P021-010840	2 - 8				
P021-010850	2 - 18				
P021-010860	3 - 1				
P021-010870	3 - 2				
P021-011020	2 - 20				
P022-003360	3 - 4				
V152-001820	1 - 7				
V204-000170	2 - 2				
V204-000180	1 - 26				
V204-000190	2 - 3				
V264-000040	1 - 5				

YAMABIKO CORPORATION

7-2 SUEHIROCHO 1-CHOME, OHME, TOKYO 198-8760, JAPAN
PHONE: 81-428-32-6118. FAX: 81-428-32-6145.



C-30
No.