



PARTS CATALOGUE

ELECTRIC HEDGE TRIMMER

DHC-3000

1. Gear Case, Cutter

No.1

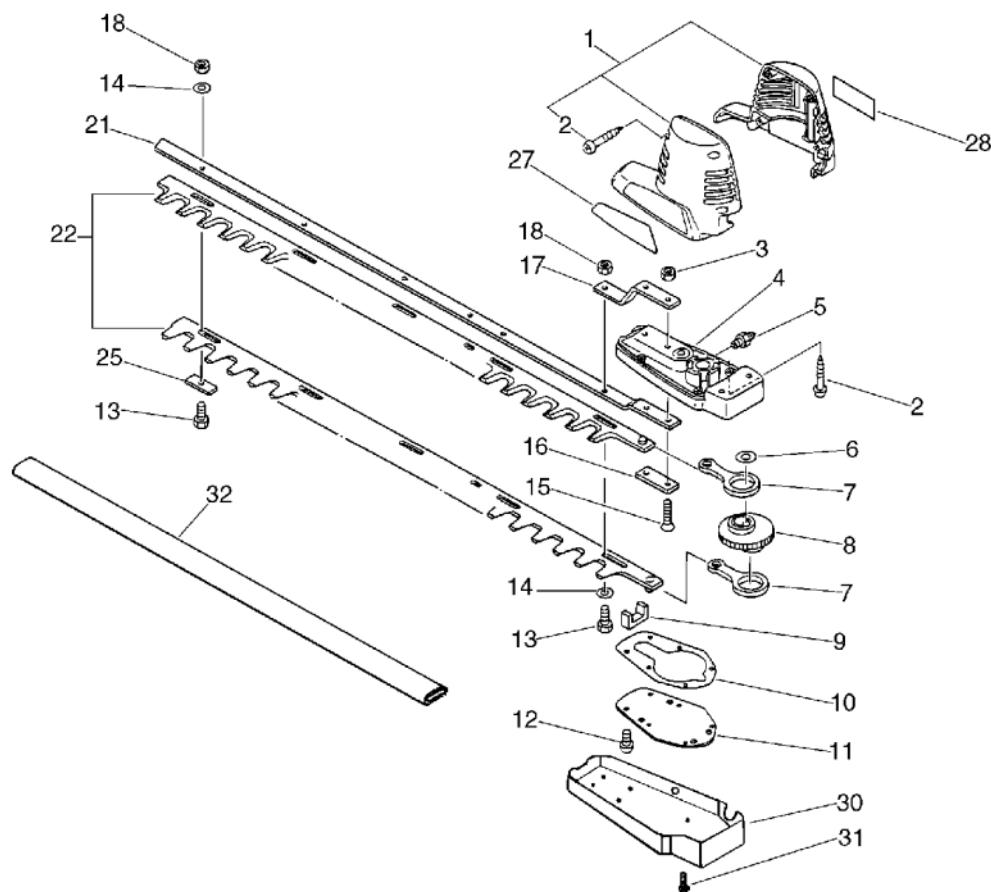

KEY	LV	PART NUMBER	Q'TY	DESCRIPTION	REMARKS	NOTE1	NOTE2
1		161004-20060	1	MOTORCASE KIT		Sus. by 161004-20061	
1		161004-20061	1	MOTORCASE KIT			
2	+	900256-04022	4	SCREW 4*22	4*22		
2		900256-04022	4	SCREW 4*22	4*22		
3		900500-00006	2	NUT 6	6		
4		610410-09960	1	CASE, GEAR		Sus. by 610410-09961	
4		610410-09961	1	CASE, GEAR			
5		880110-10860	1	NIPPLE, GREASE			
6		610350-04560	1	WASHER			
7		610330-04560	2	ROD, CONNECTING		Sus. by C532-000120	
7		610330-04561	2	ROD, CONNECTING		Sus. by C532-000120	
7		C532-000120	2	ROD, CONNECTING			
8		610312-04560	1	GEAR			
9		610425-04560	1	SEAL			
10		610414-09960	1	GASKET, GEAR HOUSING			
11		610411-09960	1	LID, GEARCASE			
12		900238-04012	4	SCREW 4*12	4*12		
13		699115-04660	4	BOLT 6	6*18L		
14		699118-04560	4	WASHER			
15		900212-06025	2	SCREW 6*25	+SF6*25		
16		610440-04560	1	HOLDER, FRAME			
17		699120-07260	1	PLATE, ANGLE			

1. Gear Case, Cutter

No.1

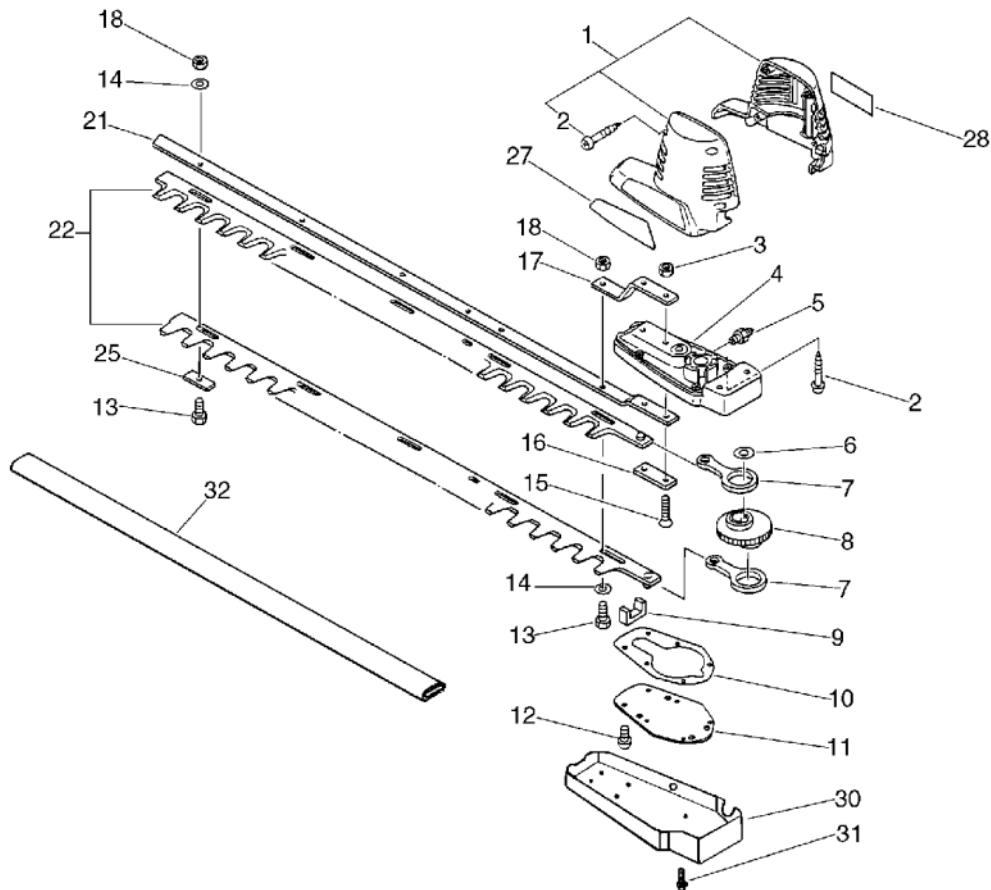

KEY	LV	PART NUMBER	Q'TY	DESCRIPTION	REMARKS	NOTE1	NOTE2
18		433022-06460	4	NUT			
21		699110-20060	1	SUPPORT, CUTTER		Sus. by X425-000110	
21		X425-000110	1	SUPPORT, CUTTER			
22		697000-20060	1	CUTTER SET		Sus. by 697000-20061	
22		697000-20061	1	CUTTER SET, HEDGE C.			
25		699213-02062	1	INSULATOR		Sus. by 699213-02063	
25		699213-02063	1	INSULATOR			
27		890151-20060	1	LABEL, MODEL			
28		890317-20060	1	LABEL, CAUTION		Sus. by 890317-20061	
28		890317-20061	1	LABEL, CAUTION			
30		660020-09960	1	COVER, GEAR CASE		Sus. by 660020-09961	
30		660020-09961	1	COVER, GEAR CASE			
31		900238-04016	5	SCREW 4*16	4*16		
32		898523-20060	1	SCABBARD, BLADE BS			

2. Handle

No.2

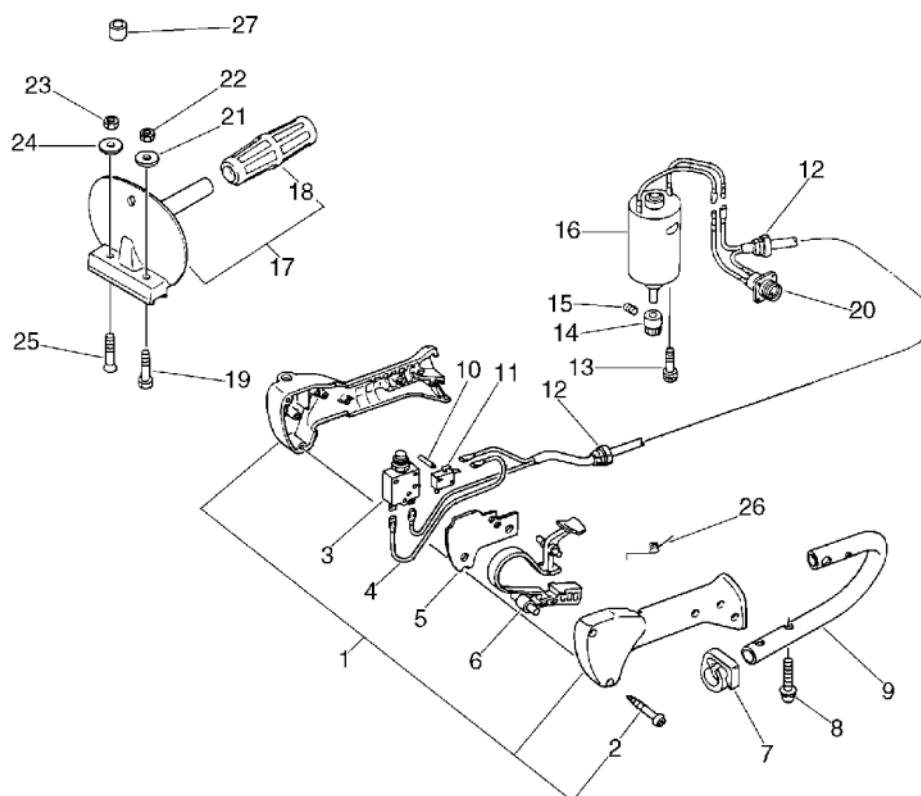

KEY	LV	PART NUMBER	Q'TY	DESCRIPTION	REMARKS	NOTE1	NOTE2
1		351102-09960	1	GRIP ASSY, F-HANDLE		Sus. by 351102-09961	
1		351102-09961	1	GRIP KIT, HANDLE			
2	+	900256-04022	5	SCREW 4*22	4*22		
3		163920-09960	1	PROTECTOR, CIRCUIT			
4		162010-09960	1	LEAD			
5		163925-09960	1	PLATE, PARTITION			
6		178010-09960	1	CONTROL, THROTTLE		Sus. by 178010-09961	
6		178010-09961	1	CONTROL, THROTTLE			
7		159112-09960	1	CLIP		Sus. by 159112-09961	
7		159112-09961	1	CLIP			
8		900238-05025	2	SCREW 5*25	5*25		
9		351210-09960	1	HANDLE, REAR			
10		100924-09960	2	PIN, STRAIGHT			
11		163400-20060	1	SWITCH, IGNITION			
12		163915-09960	2	GROMMET, CABLE			
13		900162-05030	2	BOLT, H.S. 5*30	5*30 W,SW		
14		610312-09960	1	GEAR			
15		900171-04005	1	SCREW, SET 4*5	4*5		
16		161000-20060	1	MOTOR ASSY			
17		351200-20060	1	HANDLE ASSY		Sus. by 351200-20061	
17		351200-20061	1	HANDLE ASY			

2. Handle

No.2

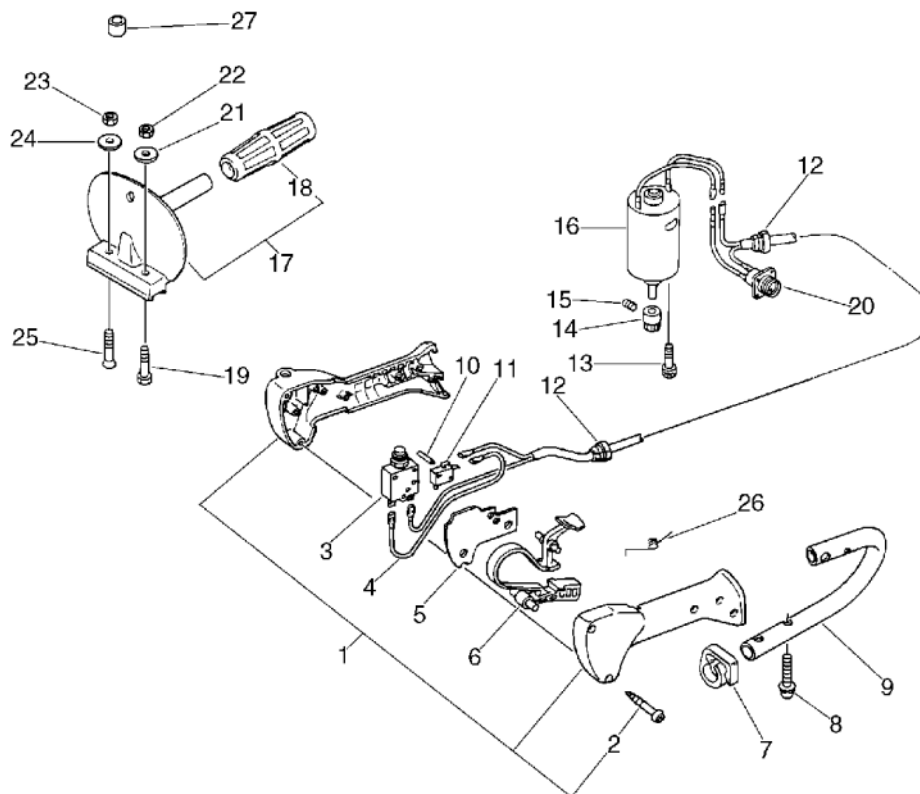

KEY	LV	PART NUMBER	Q'TY	DESCRIPTION	REMARKS	NOTE1	NOTE2
18	+	351012-09960	1	GRIP, HANDLE	22*32*115L	Sus. by 351012-09961	
18	+	351012-09961	1	GRIP, HANDLE	22*40*109		
19		699115-05360	1	BOLT			
20		162083-09960	1	HARNESS,WIRE			
21		351249-20060	1	WASHER	6.5*16*1		
22		433022-06460	1	NUT			
23		900560-00005	1	NUT, LOCK 5	5		
24		130346-32430	1	WASHER, CIRCULAR	5.5*16*1		
25		900212-05030	1	SCREW (5*30*P0.8)	+SF5*30		
26		163311-09960	1	SPRING			
27		351617-20060	1	INSERT, FRONT HANDLE			

3. Battery Case

No.3

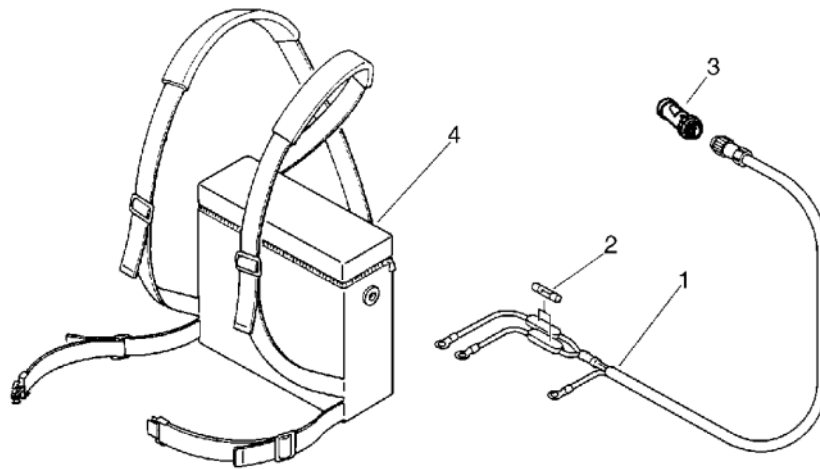

KEY	LV	PART NUMBER	Q'TY	DESCRIPTION	REMARKS	NOTE1	NOTE2
1		162080-20060	1	HARNESS, WIRE		Sus. by 162080-20061	
1		162080-20061	1	HARNESS, WIRING			
2		162029-09960	1	FUSE	DC32V-30A		
3		C152-000000	1	CONNECTOR	202-ADN8UL(10,12		
4		169310-09860	1	CASE, BATTERY			

Index

Patrs Number	Key No.	Patrs Number	Key No.	Patrs Number	Key No.
100924-09960	2 - 10	699118-04560	1 - 14		
130346-32430	2 - 24	699120-07260	1 - 17		
159112-09960	2 - 7	699213-02062	1 - 25		
159112-09961	2 - 7	699213-02063	1 - 25		
161000-20060	2 - 16	880110-10860	1 - 5		
161004-20060	1 - 1	890151-20060	1 - 27		
161004-20061	1 - 1	890317-20060	1 - 28		
162010-09960	2 - 4	890317-20061	1 - 28		
162029-09960	3 - 2	898523-20060	1 - 32		
162080-20060	3 - 1	900162-05030	2 - 13		
162080-20061	3 - 1	900171-04005	2 - 15		
162083-09960	2 - 20	900212-05030	2 - 25		
163311-09960	2 - 26	900212-06025	1 - 15		
163400-20060	2 - 11	900238-04012	1 - 12		
163915-09960	2 - 12	900238-04016	1 - 31		
163920-09960	2 - 3	900238-05025	2 - 8		
163925-09960	2 - 5	900256-04022	1 - 2		
169310-09860	3 - 4	900256-04022	1 - 2		
178010-09960	2 - 6	900256-04022	2 - 2		
178010-09961	2 - 6	900500-00006	1 - 3		
351012-09960	2 - 18	900560-00005	2 - 23		
351012-09961	2 - 18	C152-000000	3 - 3		
351102-09960	2 - 1	C532-000120	1 - 7		
351102-09961	2 - 1	X425-000110	1 - 21		
351200-20060	2 - 17				
351200-20061	2 - 17				
351210-09960	2 - 9				
351249-20060	2 - 21				
351617-20060	2 - 27				
433022-06460	1 - 18				
433022-06460	2 - 22				
610312-04560	1 - 8				
610312-09960	2 - 14				
610330-04560	1 - 7				
610330-04561	1 - 7				
610350-04560	1 - 6				
610410-09960	1 - 4				
610410-09961	1 - 4				
610411-09960	1 - 11				
610414-09960	1 - 10				
610425-04560	1 - 9				
610440-04560	1 - 16				
660020-09960	1 - 30				
660020-09961	1 - 30				
697000-20060	1 - 22				
697000-20061	1 - 22				
699110-20060	1 - 21				
699115-04660	1 - 13				
699115-05360	2 - 19				

YAMABIKO CORPORATION

7-2 SUEHIROCHO 1-CHOME, OHME, TOKYO 198-8760, JAPAN
PHONE: 81-428-32-6118. FAX: 81-428-32-6145.



3000
No.