

shindaiwa[®]

PARTS CATALOGUE

HEDGE TRIMMER DH2510 EC2-2

DH2510 EC2-2

1. CYLINDER, MUFFLER

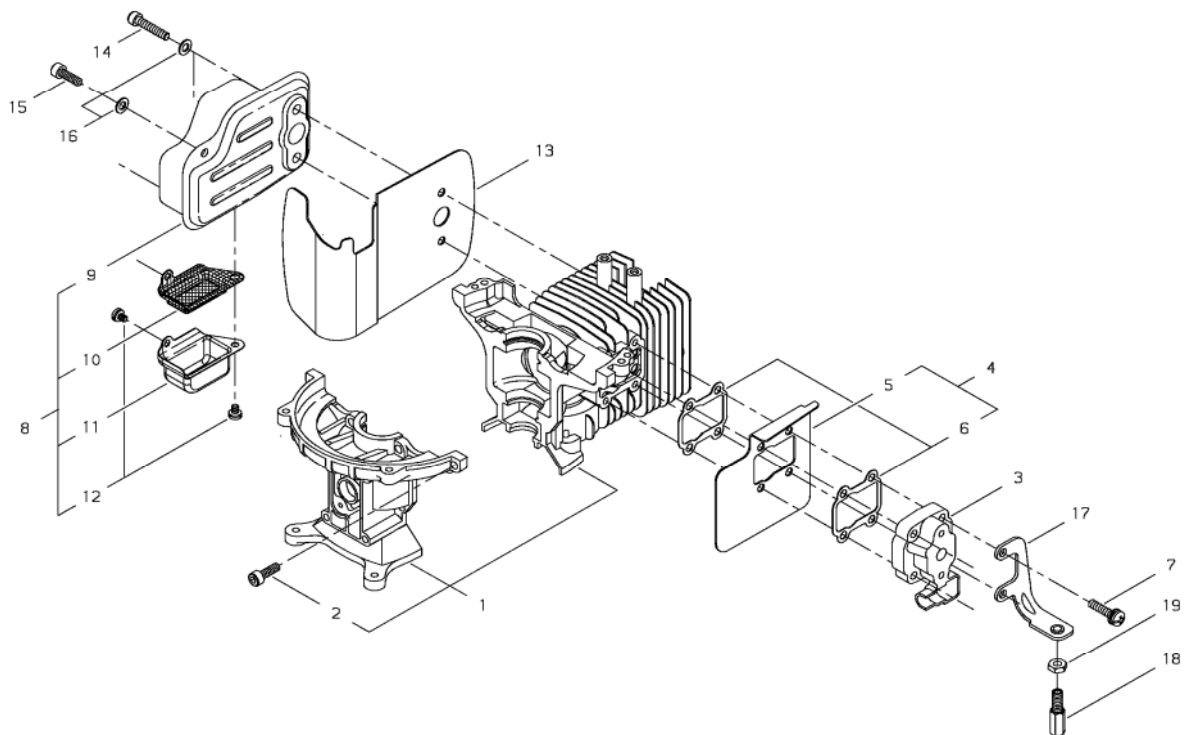

KEY	LV	PART NUMBER	Q'TY	DESCRIPTION	REMARKS	NOTE1	NOTE2
1		60600-98351	1	CYLINDER BLOCK SET			
2	▪	01020-05160	6	BOLT	M5*16 BLACK	M5x16	
3		62902-12310	1	REED VALVE			
4		62902-12320	1	BAFFLE PLATE COMP			
5	▪	62901-12320	1	BAFFLE PLATE			
6	▪	62901-12220	2	GASKET			
7		11206-05225	4	SCREW,PM-SPW	M5*22		
8		38800-15010	1	MUFFLER ASSY			
9	▪	62902-15111	1	MUFFLER			
10	▪	62902-15131	1	SCREEN			
11	▪	38800-15160	1	EXHAUST OUTLET			
12	▪	11204-04060	2	SCREW,PM-SW			
13		62901-15210	1	GASKET			
14		62901-15310	2	BOLT		M5x25	
15		01020-05160	1	BOLT	M5*16 BLACK	M5x16	
16		01610-05080	3	WASHER			
17		62600-83310	1	BRACKET			
18		62902-83310	1	CABLE ADJUSTER			
19		01501-06048	1	NUT		M6	

2. CRANKCASE, CYLINDER COVER

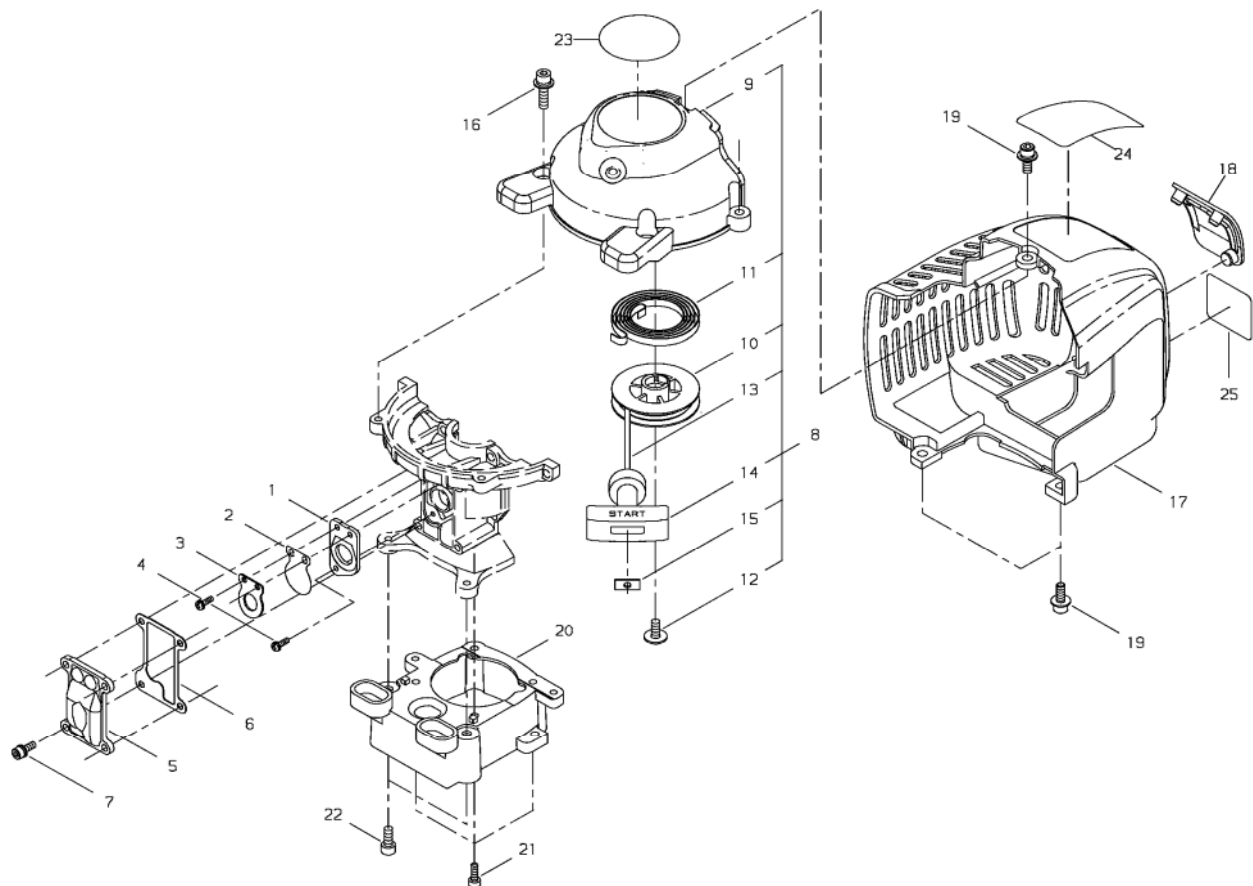

KEY	LV	PART NUMBER	Q'TY	DESCRIPTION	REMARKS	NOTE1	NOTE2
1		62901-21320	1	INSULATOR			
2		72320-83121	1	VALVE			
3		72320-83132	1	STOPPER			
4		01211-03100	3	SCREW-SW	M3*10	M3*10	
5		62901-21120	1	COVER			
6		62901-21130	1	GASKET			
7		11022-04120	4	BOLT-SPW	M4*12	M4*12	
8		62600-31011	1	FAN COVER ASSY			
9		62600-31111	1	FAN COVER			
10		62600-31320	1	REEL			
11		70030-75130	1	RECOIL SPRING			
12		62600-31310	1	SCREW			
13		37076-75140	1	ROPE			
14		20010-75190	1	STARTER KNOB			
15		20010-75210	1	STOPPER			
16		11060-05202	4	BOLT ADHESIVE		M5*20	
17		62600-32110	1	CYLINDER COVER			
18		62901-32312	1	GROMMET			
19		11060-05141	3	BOLT ADHESIVE		M5*14	
20		62600-33310	1	ADAPTER			
21		01020-04120	4	BOLT		M4*12	
22		01020-05120	2	BOLT	M5*12	M5*12	
23		19420-00070	1	LABEL TRADE			
24		19420-00106	1	LABEL TRADE			shindaiwa、C4
25		62602-91320	1	LABEL TRADE			

3. PISTON, VALVE

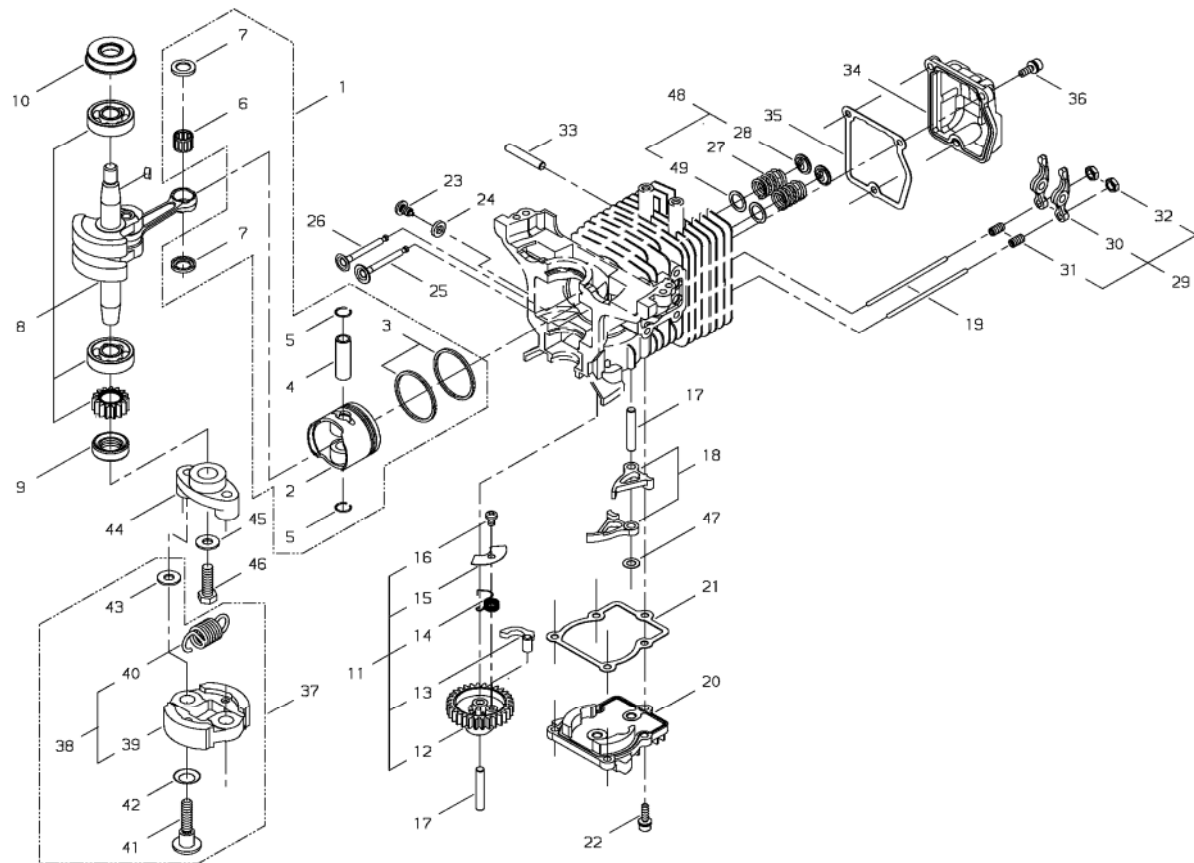

KEY	LV	PART NUMBER	Q'TY	DESCRIPTION	REMARKS	NOTE1	NOTE2
1		62902-41310	1	PISTON SET			
2	▪	62902-41110	1	PISTON			
3	▪	62902-41120	2	PISTON RING			
4	▪	62901-41210	1	PISTON PIN			
5	▪	20000-41320	2	SNAP RING			
6	▪	62901-41230	1	NEEDLE BEARING			
7	▪	37019-41240	2	THRUST WASHER			
8		62600-42020	1	CRANK SHAFT COMP			
9		62901-42260	1	OIL SEAL			
10		62901-42270	1	OIL SEAL			
11		62905-43011	1	CAM GEAR ASSY			
12	▪	62902-43310	1	CAM GEAR			
13	▪	62907-43120	1	WEIGHT			
14	▪	17520-08900	1	COIL SPRING			
15	▪	62905-43131	1	PLATE			
16	▪	01280-04062	1	SCREW,TAPPING			
17		12492-50290	2	ROLLER	5*L29.8	φ5*L29.8	
18		62907-43210	2	LIFTER			
19		62908-43220	2	PUSH ROD			
20		62901-43330	1	CAM GEAR COVER			
21		62901-43240	1	GASKET			
22		11022-04140	5	BOLT-SPW	M4-14	M4*14	
23		62901-43310	1	SCREW			
24		15401-10028	1	COLLAR	5.5,10 T=2		
25		62902-44111	1	INTAKE VALVE			
26		62902-44121	1	EXHAUST VALVE			

3. PISTON, VALVE

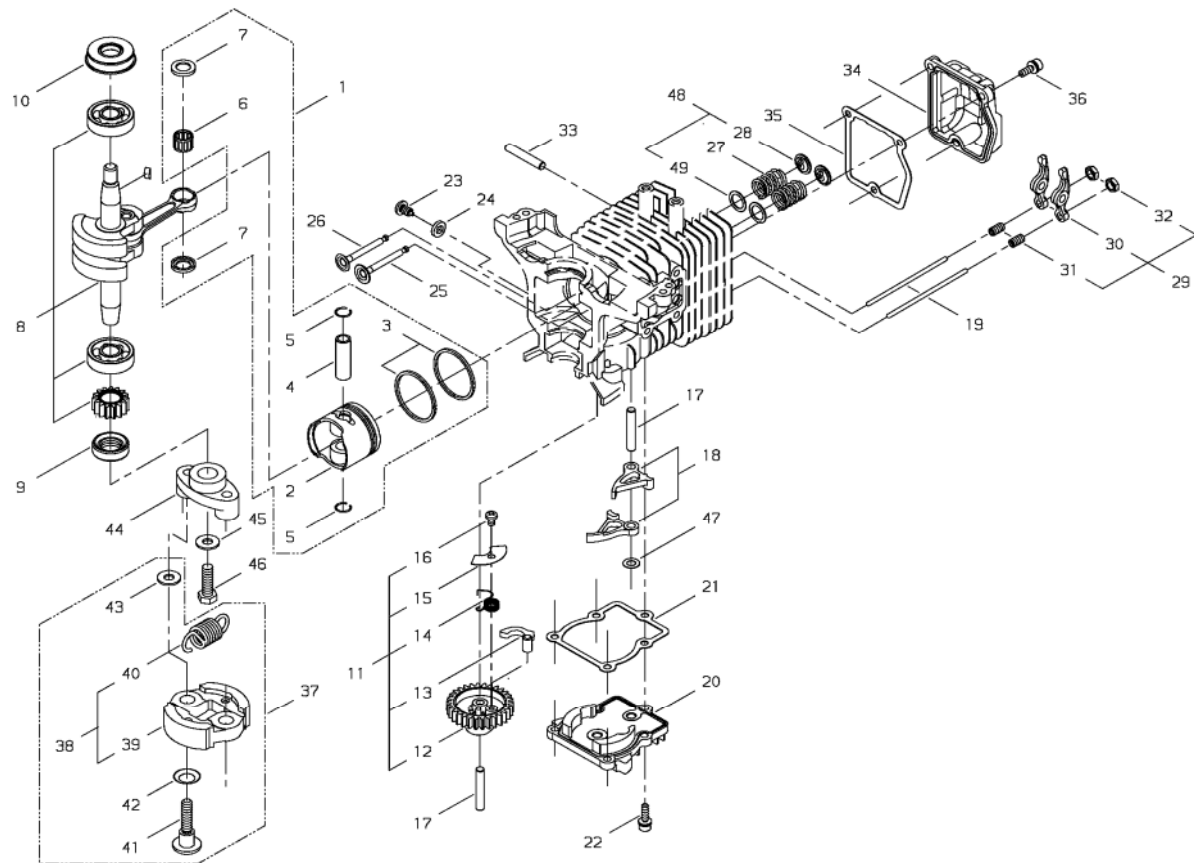

KEY	LV	PART NUMBER	Q'TY	DESCRIPTION	REMARKS	NOTE1	NOTE2
27		62901-44130	2	VALVE SPRING			
28	▪	62908-44140	2	RETAINER			
29		62907-44010	2	ROCKER ARM ASSY			
30	▪	62901-44210	2	ROCKER ARM			
31	▪	62907-44220	2	ADJUST SCREW			
32	▪	62901-44231	2	NUT			
33		12492-50310	1	ROLLER	NTN F5*31.8	φ5×31.8	
34		62901-44241	1	ROCKER ARM COVER			
35		62901-44250	1	GASKET			
36		11022-04140	3	BOLT-SPW	M4-14	M4*14	
37		62600-51010	1	CLUTCH SET			
38	▪	62600-51020	1	CLUTCH SHOE ASSY			
39	▪ ▪	20115-51111	2	CLUTCH SHOE			
40	▪ ▪	62600-51310	1	SPRING			
41	▪	20087-51210	2	BOLT			
42	▪	20087-51231	2	SPRING PLATE			
43	▪	22100-71430	2	WASHER			
44		20870-51211	1	CLUTCH BOSS			
45		22100-71430	1	WASHER			
46		20870-51220	1	BOLT		M6*18	
47		11620-10000	1	WASHER	T0.3		
48		60908-98370	2	RETAINER SET			
49	▪	62908-44310	2	PLATE			

4. MAGNETO

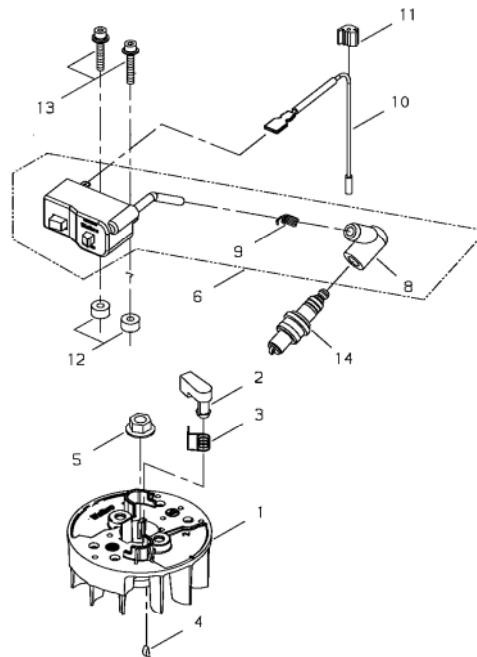

KEY	LV	PART NUMBER	Q'TY	DESCRIPTION	REMARKS	NOTE1	NOTE2
1		62600-71111	1	ROTOR			
2		20870-71120	1	RATCHET			
3		20870-71130	1	COIL SPRING			
4		02403-03100	1	KEY	3*10	3*10	
5		20035-71220	1	NUT		M8	
6		62600-71320	1	COIL ASSY			
8		62905-71250	1	PLUG CAP			
9		62905-71320	1	COIL SPRING			
10		14350-02001	1	LEAD WIRE			
11		62901-71310	1	GROMMET			
12		70030-71620	2	INSULATOR			
13		11024-04265	2	BOLT-SLPW	M4*26	M4*26	
14		13001-10005	1	PLIG	NGK CMR5H	CMR5H	

5. CARBURETOR, CLEANER

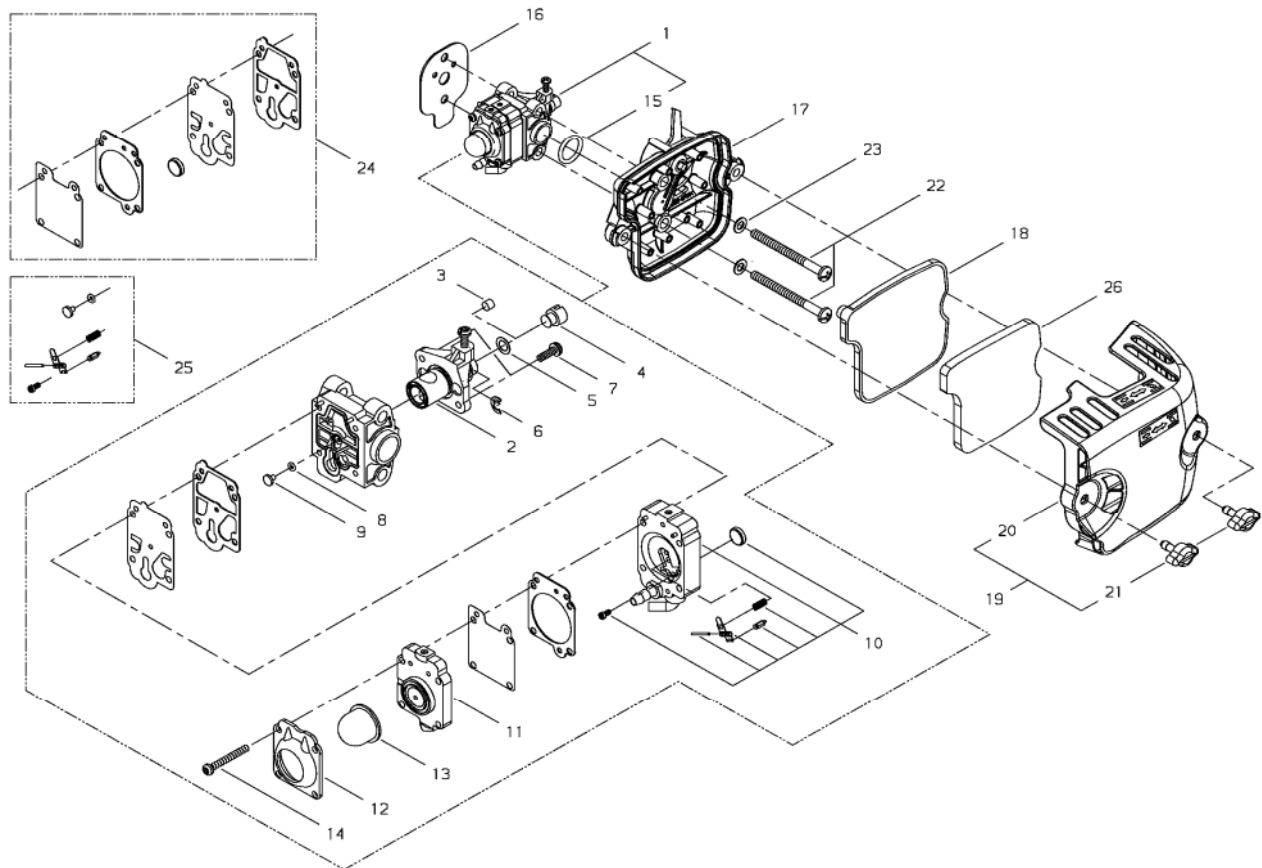

KEY	LV	PART NUMBER	Q'TY	DESCRIPTION	REMARKS	NOTE1	NOTE2
1		62600-81010	1	CABURETOR ASSY			
2	▪	62901-81320	1	VALVE			
3	▪	62074-81320	1	PLAG			
4	▪	72933-81450	1	SWIVEL			
5	▪	20089-81185	1	WASHER			
6	▪	20036-81195	1	E RING			
7	▪	70064-81290	2	SCREW	M3*10		
8	▪	70097-81220	1	O-RING			
9	▪	62902-81310	1	MAIN JET			
10	▪	37013-81350	1	PUMP BODY ASSY			
11	▪	20016-81420	1	PUMP BASE COMP			
12	▪	20016-81510	1	PUMP COVER			
13	▪	20036-81670	1	PRIMER PUMP			
14	▪	20016-81140	4	SCREW			
15	▪	20016-81250	1	O RING			
16		62901-81211	1	GASKET			
17		62908-82010	1	CLEANER BODY ASSY			
18		62908-82120	1	FILTER			
19		62908-82030	1	CLEANER COVER ASSY			
20	▪	62908-82130	1	CLEANER COVER			
21	▪	62901-82330	2	KNOB			
22		11203-05605	2	SCREW,PM			
23		01613-05080	2	WASHER			
24		60902-98030	1	GASKRT			
25		60902-98040	1	VALVE SET			
26		62908-82310	1	PREFILTER			

6. FUEL TANK

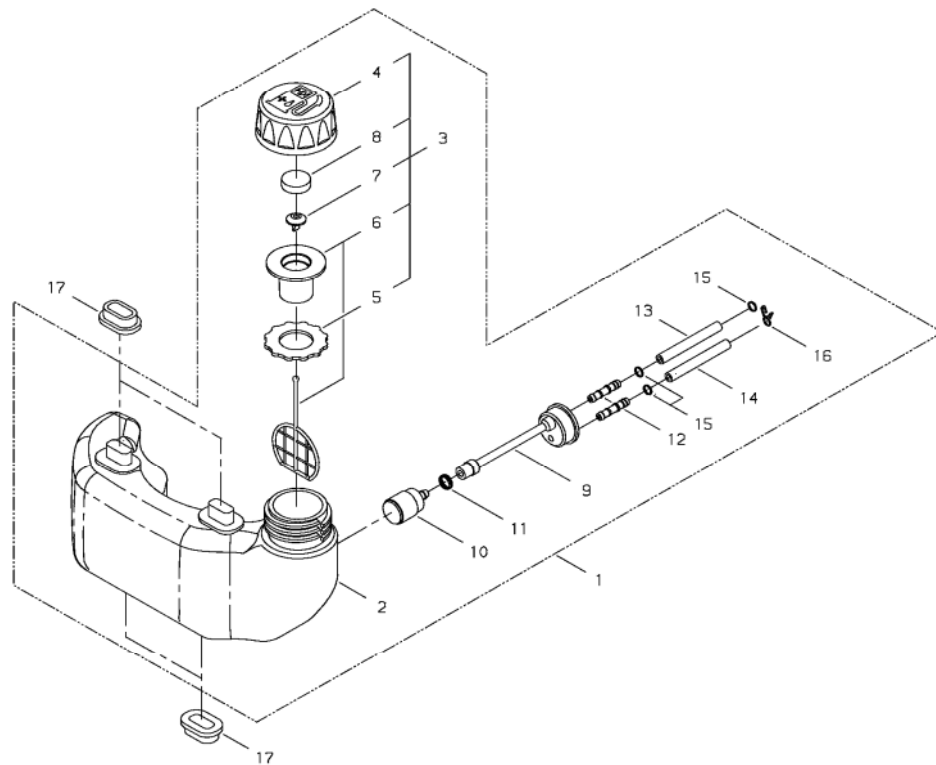

KEY	LV	PART NUMBER	Q'TY	DESCRIPTION	REMARKS	NOTE1	NOTE2
1		62601-85310	1	FUEL TANK ASSY			
2	▪	62600-85110	1	FUEL TANK			
3	▪	62800-85021	1	FUEL CAP ASSY			
4	▪ ▪	20870-85310	1	FUEL CAP			
5	▪ ▪	20870-85160	1	GASKET			
6	▪ ▪	62800-85310	1	HOLDER COMP			
7	▪ ▪	20870-85320	1	VALVE FUEL			
8	▪ ▪	20870-85210	1	SEAL,CIRCULAR			
9	▪	20870-85121	1	FUEL PIPE			
10	▪	20016-85400	1	FUEL FILTER			
11	▪	20000-85350	1	CLAMP B			
12	▪	72933-85620	2	JOINT			
13	▪	20110-83311	1	PIPE			
14	▪	20112-85361	1	PIPE			
15	▪	20020-85540	3	CLIP			
16	▪	37013-85310	1	CLIP			
17		62901-85220	4	TANK CUSHION			

7. CUTTER

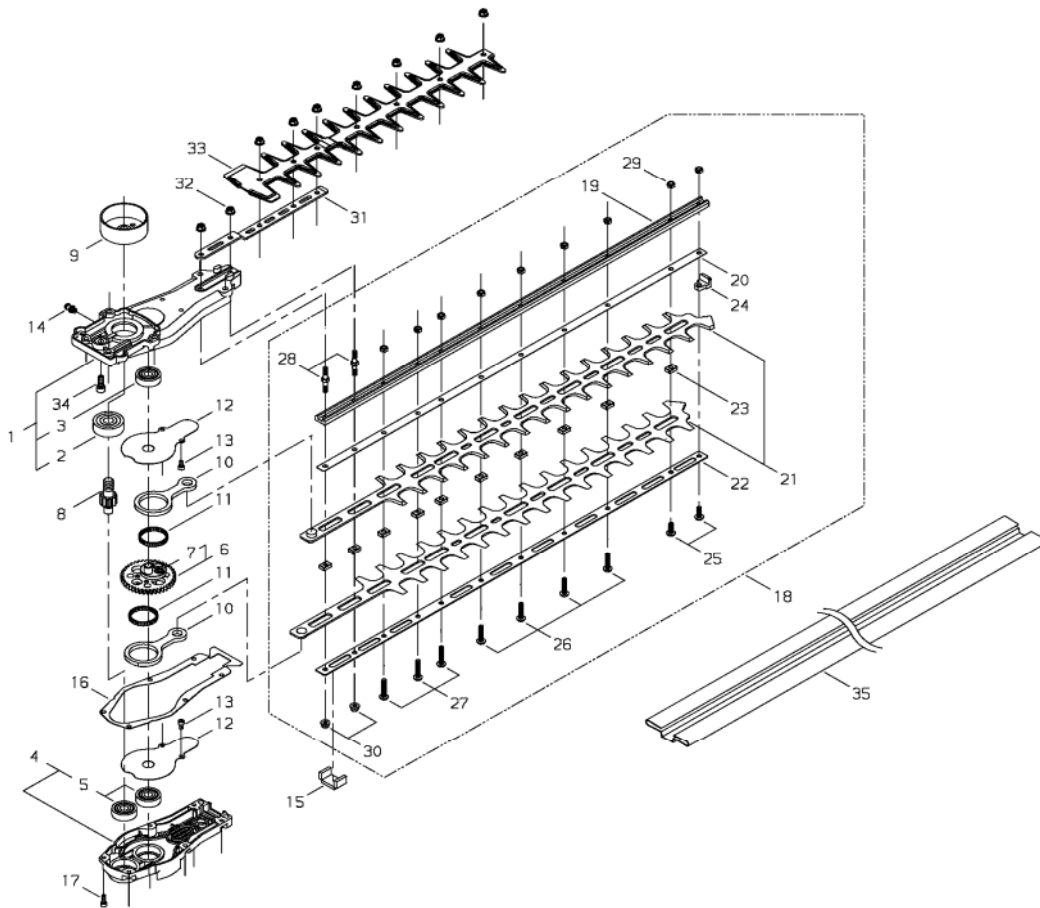

KEY	LV	PART NUMBER	Q'TY	DESCRIPTION	REMARKS	NOTE1	NOTE2
1		63600-61010	1	GEAR CASE COMP			
2	•	02006-06301	1	BEARING		6301DDU	
3	•	02002-06200	1	BEARING		6200ZZ	
4		63600-61020	1	CASE COVER COMP			
5	•	02002-06200	2	BEARING		6200ZZ	
6		63600-61030	1	GEAR COMP			
7	•	63600-61320	4	BOLT		M5x6	
8		63600-61150	1	PINION SHAFT			
9		20870-61420	1	CLUTCH DRUM			
10		63600-61170	2	ROD			
11		63600-61330	2	BEARING, NEEDLE			
12		63600-61340	2	PLATE			
13		01020-04080	4	BOLT		M4x8	
14		20870-61640	1	GREASE NIPPLE			
15		63600-61350	1	SEAL			
16		63600-61360	1	GASKET			
17		01020-04140	6	BOLT		M4x14	
18		63606-62011	1	CUTTER ASSY		24"	
19	•	18501-60006	1	GUIDE BAR		24"	
20	•	63602-62310	1	UPPER PLATE			
21	•	18500-60106	2	BLADE		24" t.2	
22	•	63602-62320	1	LOWER PLATE			
23	•	63600-62331	10	SPACER			
24	•	63600-62340	1	BLOCK			
25	•	11230-05140	2	SCREW BUTTON		M5x14	
26	•	11230-05220	4	SCREW BUTTON		M5x22	

7. CUTTER

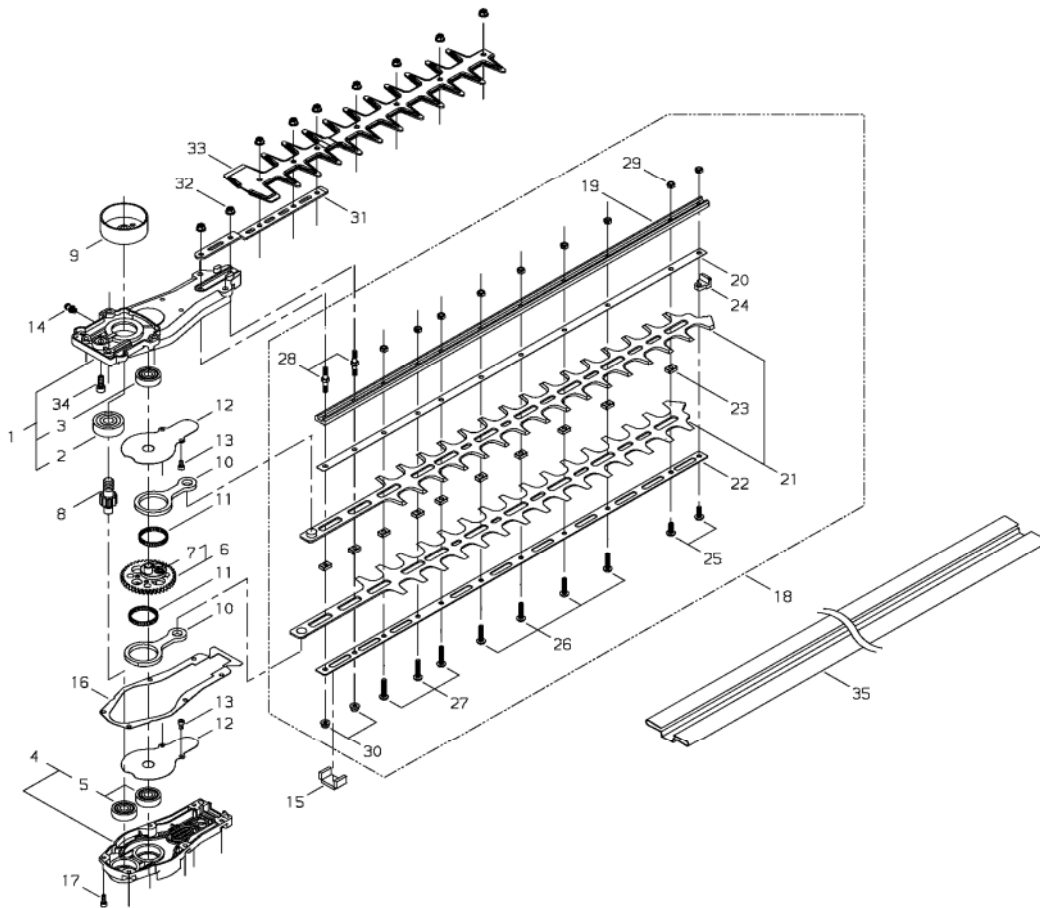

KEY	LV	PART NUMBER	Q'TY	DESCRIPTION	REMARKS	NOTE1	NOTE2
27	•	11230-05250	3	SCREW BUTTON		M5x25	
28	•	63600-62370	2	BOLT			
29	•	72935-61240	9	LOCK NUT		M5	
30	•	11525-05231	2	NUT	M5	M5	
31		63600-62361	1	HOLDER			
32		11525-05231	9	NUT	M5	M5	
33		63606-63310	1	PROTECTOR			
34		01020-06160	3	BOLT		M6x16	
35		19601-01504	1	BLADE COVER		24"	

8. HANDLE

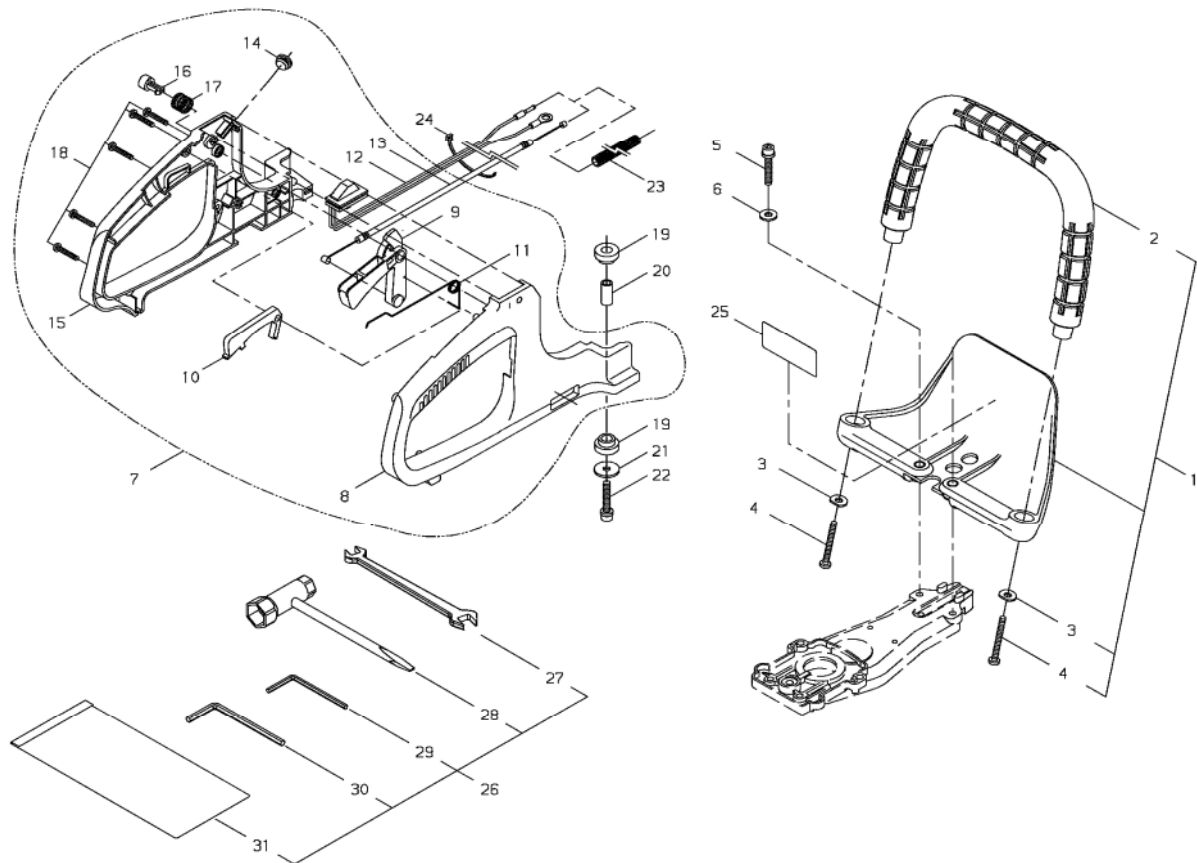

KEY	LV	PART NUMBER	Q'TY	DESCRIPTION	REMARKS	NOTE1	NOTE2
1		62803-64012	1	FRONT HANDLE ASSY			
2	▪	62803-64111	1	FRONT HANDLE			
3	▪	62803-64330	2	WASHER			
4	▪	72935-61230	2	BOLT TAPPING			
5		11020-06300	2	BOLT SW		M6x30	
6		23510-64210	2	WASHER		φ16xφ6.5 t=1.6	
7		64601-65010	1	REAR HANDLE			
8	▪	62803-65114	1	RIGHT HANDLE			
9	▪	62803-65312	1	THROTTLE LEVER			
10	▪	62803-65322	1	LOCK LEVER			
11	▪	62803-65350	1	COIL SPRING			
12	▪	62803-65332	1	SWITCH			
13	▪	64601-65310	1	THROTTLE CABLE			
14	▪	22150-33630	1	PLUG			
15	▪	62803-65124	1	LEFT HANDLE			
16	▪	70871-65170	1	BUTTON			
17	▪	70871-65180	1	COIL SPRING			
18	▪	62803-65360	5	SCREW TAPPING		φ4x18	
19		20870-65421	4	CUSHION			
20		15401-10200	2	COLLAR			
21		15401-20008	2	COLLAR		φ23xφ6.5 t=2	
22		11020-06350	2	BOLT SW		M6x35	
23		64600-65320	1	TUBE			
24		15210-12305	1	BAND			
25		19402-00148	1	LABEL,CAUTION			

8. HANDLE

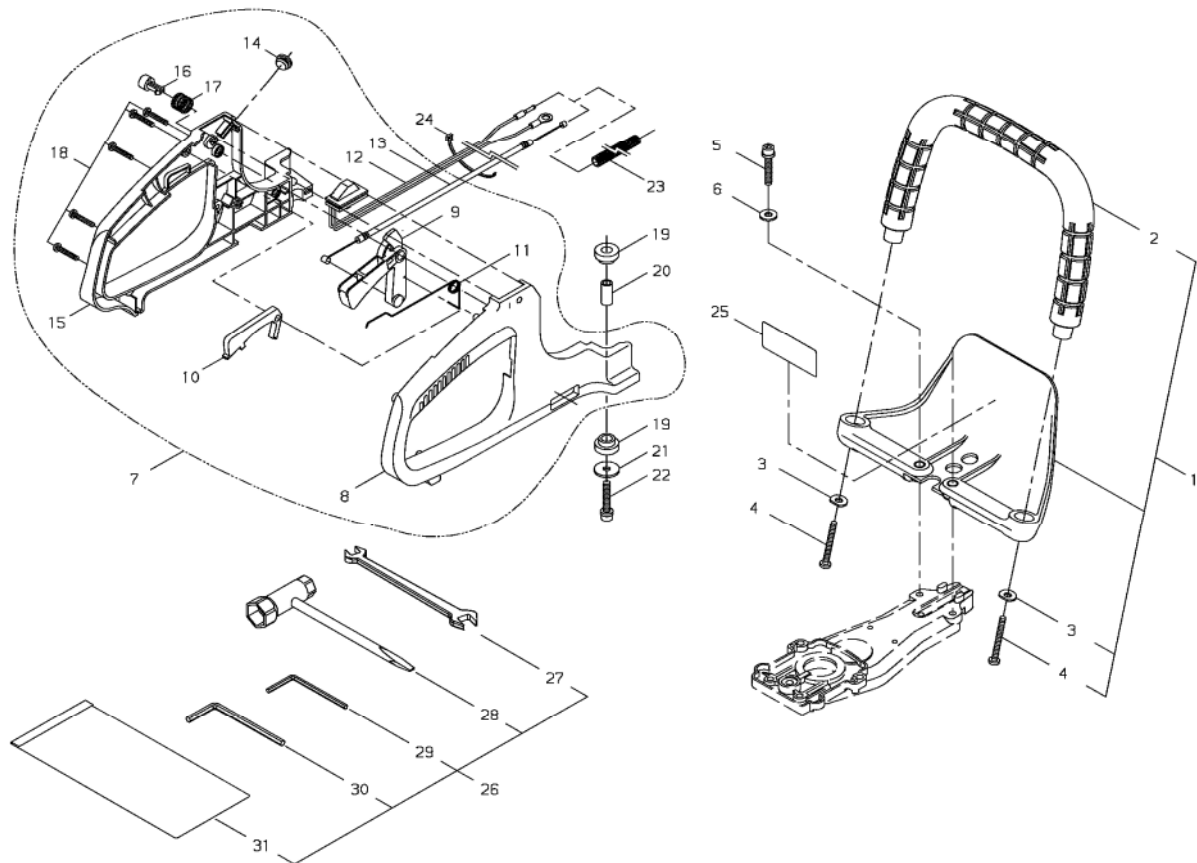

KEY	LV	PART NUMBER	Q'TY	DESCRIPTION	REMARKS	NOTE1	NOTE2
26		64902-92310	1	TOOL SET			
27	▪	22000-91120	1	SPANNER		8x10	
28	▪	22580-91180	1	PLUG WRENCH		13x16	
29	▪	09026-04001	1	HEXA WRENCH	4MM M5ㄗ	4mm M5	
30	▪	09026-05001	1	HEXA WRENCH 6MM		5mm M6	
31	▪	19639-01400	1	BAG,PACKING	140*200*T0.08		

9. SHORT BLOCK

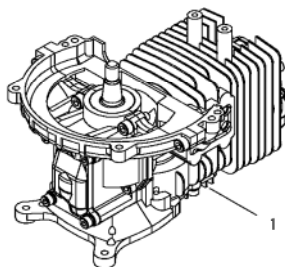

KEY	LV	PART NUMBER	Q'TY	DESCRIPTION	REMARKS	NOTE1	NOTE2
1		60600-98370	1	SHORT BLOCK			

Index

Patrs Number	Key No.	Patrs Number	Key No.	Patrs Number	Key No.
01020-04080	7 - 13	19601-01504	7 - 35	60908-98370	3 - 48
01020-04120	2 - 21	19639-01400	8 - 31	62074-81320	5 - 3
01020-04140	7 - 17	20000-41320	3 - 5	62600-31011	2 - 8
01020-05120	2 - 22	20000-85350	6 - 11	62600-31111	2 - 9
01020-05160	1 - 2	20010-75190	2 - 14	62600-31310	2 - 12
01020-05160	1 - 15	20010-75210	2 - 15	62600-31320	2 - 10
01020-06160	7 - 34	20016-81140	5 - 14	62600-32110	2 - 17
01211-03100	2 - 4	20016-81250	5 - 15	62600-33310	2 - 20
01280-04062	3 - 16	20016-81420	5 - 11	62600-42020	3 - 8
01501-06048	1 - 19	20016-81510	5 - 12	62600-51010	3 - 37
01610-05080	1 - 16	20016-85400	6 - 10	62600-51020	3 - 38
01613-05080	5 - 23	20020-85540	6 - 15	62600-51310	3 - 40
02002-06200	7 - 3	20035-71220	4 - 5	62600-71111	4 - 1
02002-06200	7 - 5	20036-81195	5 - 6	62600-71320	4 - 6
02006-06301	7 - 2	20036-81670	5 - 13	62600-81010	5 - 1
02403-03100	4 - 4	20087-51210	3 - 41	62600-83310	1 - 17
09026-04001	8 - 29	20087-51231	3 - 42	62600-85110	6 - 2
09026-05001	8 - 30	20089-81185	5 - 5	62601-85310	6 - 1
11020-06300	8 - 5	20110-83311	6 - 13	62602-91320	2 - 25
11020-06350	8 - 22	20112-85361	6 - 14	62800-85021	6 - 3
11022-04120	2 - 7	20115-51111	3 - 39	62800-85310	6 - 6
11022-04140	3 - 22	20870-51211	3 - 44	62803-64012	8 - 1
11022-04140	3 - 36	20870-51220	3 - 46	62803-64111	8 - 2
11024-04265	4 - 13	20870-61420	7 - 9	62803-64330	8 - 3
11060-05141	2 - 19	20870-61640	7 - 14	62803-65114	8 - 8
11060-05202	2 - 16	20870-65421	8 - 19	62803-65124	8 - 15
11203-05605	5 - 22	20870-71120	4 - 2	62803-65312	8 - 9
11204-04060	1 - 12	20870-71130	4 - 3	62803-65322	8 - 10
11206-05225	1 - 7	20870-85121	6 - 9	62803-65332	8 - 12
11230-05140	7 - 25	20870-85160	6 - 5	62803-65350	8 - 11
11230-05220	7 - 26	20870-85210	6 - 8	62803-65360	8 - 18
11230-05250	7 - 27	20870-85310	6 - 4	62901-12220	1 - 6
11525-05231	7 - 30	20870-85320	6 - 7	62901-12320	1 - 5
11525-05231	7 - 32	22000-91120	8 - 27	62901-15210	1 - 13
11620-10000	3 - 47	22100-71430	3 - 43	62901-15310	1 - 14
12492-50290	3 - 17	22100-71430	3 - 45	62901-21120	2 - 5
12492-50310	3 - 33	22150-33630	8 - 14	62901-21130	2 - 6
13001-10005	4 - 14	22580-91180	8 - 28	62901-21320	2 - 1
14350-02001	4 - 10	23510-64210	8 - 6	62901-32312	2 - 18
15210-12305	8 - 24	37013-81350	5 - 10	62901-41210	3 - 4
15401-10028	3 - 24	37013-85310	6 - 16	62901-41230	3 - 6
15401-10200	8 - 20	37019-41240	3 - 7	62901-42260	3 - 9
15401-20008	8 - 21	37076-75140	2 - 13	62901-42270	3 - 10
17520-08900	3 - 14	38800-15010	1 - 8	62901-43240	3 - 21
18500-60106	7 - 21	38800-15160	1 - 11	62901-43310	3 - 23
18501-60006	7 - 19	60600-98351	1 - 1	62901-43330	3 - 20
19402-00148	8 - 25	60600-98370	9 - 1	62901-44130	3 - 27
19420-00070	2 - 23	60902-98030	5 - 24	62901-44210	3 - 30
19420-00106	2 - 24	60902-98040	5 - 25	62901-44231	3 - 32

Index

Patrs Number	Key No.	Patrs Number	Key No.	Patrs Number	Key No.
62901-44241	3 - 34	63602-62310	7 - 20		
62901-44250	3 - 35	63602-62320	7 - 22		
62901-71310	4 - 11	63606-62011	7 - 18		
62901-81211	5 - 16	63606-63310	7 - 33		
62901-81320	5 - 2	64600-65320	8 - 23		
62901-82330	5 - 21	64601-65010	8 - 7		
62901-85220	6 - 17	64601-65310	8 - 13		
62902-12310	1 - 3	64902-92310	8 - 26		
62902-12320	1 - 4	70030-71620	4 - 12		
62902-15111	1 - 9	70030-75130	2 - 11		
62902-15131	1 - 10	70064-81290	5 - 7		
62902-41110	3 - 2	70097-81220	5 - 8		
62902-41120	3 - 3	70871-65170	8 - 16		
62902-41310	3 - 1	70871-65180	8 - 17		
62902-43310	3 - 12	72320-83121	2 - 2		
62902-44111	3 - 25	72320-83132	2 - 3		
62902-44121	3 - 26	72933-81450	5 - 4		
62902-81310	5 - 9	72933-85620	6 - 12		
62902-83310	1 - 18	72935-61230	8 - 4		
62905-43011	3 - 11	72935-61240	7 - 29		
62905-43131	3 - 15				
62905-71250	4 - 8				
62905-71320	4 - 9				
62907-43120	3 - 13				
62907-43210	3 - 18				
62907-44010	3 - 29				
62907-44220	3 - 31				
62908-43220	3 - 19				
62908-44140	3 - 28				
62908-44310	3 - 49				
62908-82010	5 - 17				
62908-82030	5 - 19				
62908-82120	5 - 18				
62908-82130	5 - 20				
62908-82310	5 - 26				
63600-61010	7 - 1				
63600-61020	7 - 4				
63600-61030	7 - 6				
63600-61150	7 - 8				
63600-61170	7 - 10				
63600-61320	7 - 7				
63600-61330	7 - 11				
63600-61340	7 - 12				
63600-61350	7 - 15				
63600-61360	7 - 16				
63600-62331	7 - 23				
63600-62340	7 - 24				
63600-62361	7 - 31				
63600-62370	7 - 28				

YAMABIKO CORPORATION

7-2 SUEHIROCHO 1-CHOME, OHME, TOKYO 198-8760, JAPAN
PHONE: 81-428-32-6118. FAX: 81-428-32-6145.

shindaiwa[®]

C2-2
No.