

DCS-1600

Serial number: 35001001-99999999

Last update date: 06/04/2020

TABLE OF CONTENTS

MOTOR	1
CHAIN BRAKE.....	3
ACCESSORIES.....	5

MOTOR

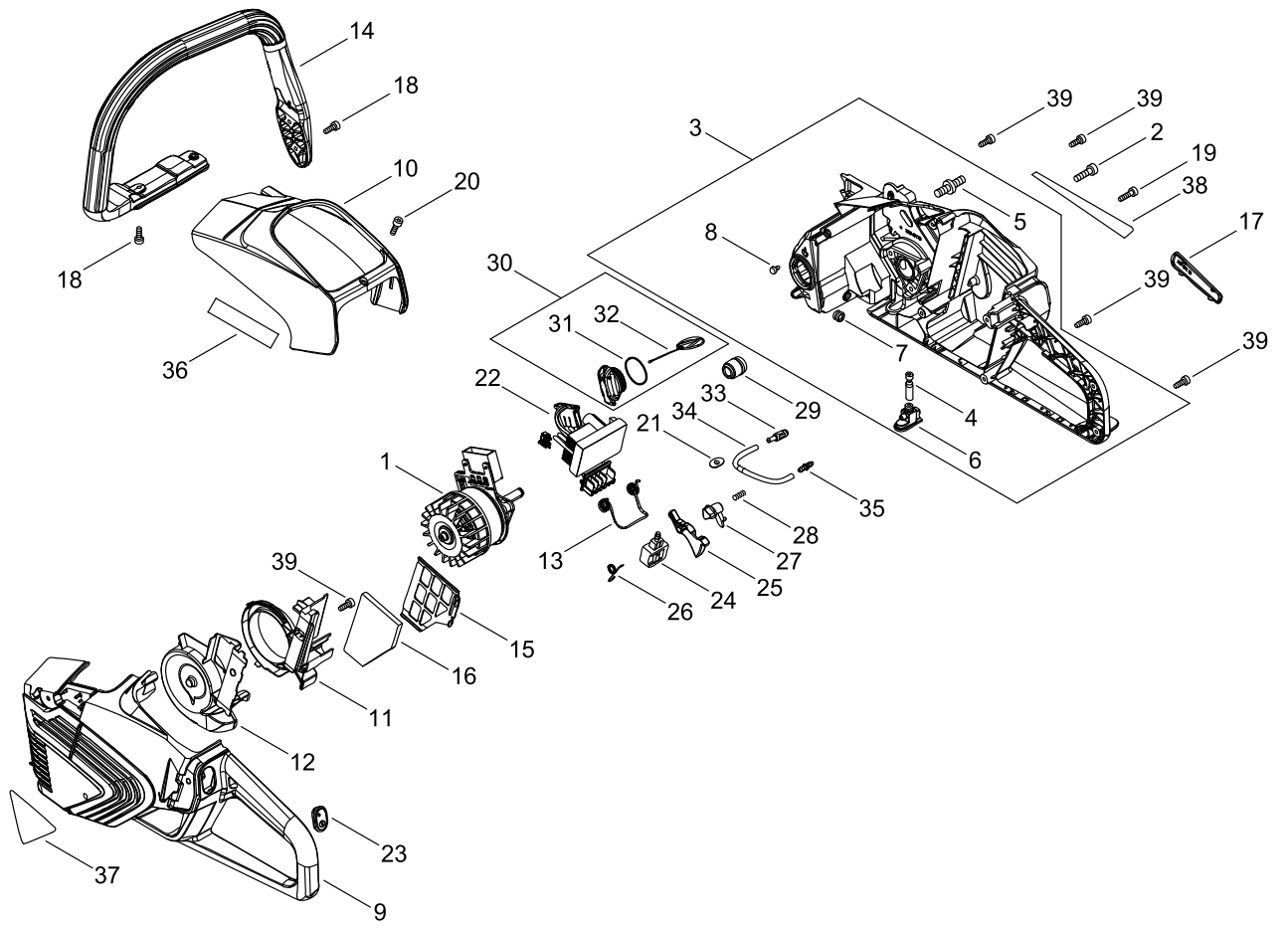

MOTOR

Key No.	LV (+)	Part No	Description	Qty	Standard
1		A054-000290	MOTOR,ASM	1	
2		V805-000160	BOLT, TORX 5	3	TB-5*20 10.9
3		P100-004470	COVER,MOTOR ASY	1	
4	+	C022-000072	AUTO-OILER ASSEMBLY	1	
5	+	V225-000370	BOLT,STUD 8	2	M8
6	+	V470-002350	PIPE	1	
7	+	132115-01461	GROMMET	1	
8	+	A356-000130	VALVE,CHECK	1	
9		A539-000440	COVER,MOTOR	1	
10		J470-008660	COVER	1	
11		E103-001520	CASE,FAN	1	
12		E103-001530	CASE,FAN	1	
13		V452-001790	SPRING,TORSION	1	
14		C400-001650	HANDLE, FRONT	1	
15		A232-001960	LID,CLEANER	1	
16		A226-002180	ELEMENT, AIR FILTER	1	
17		C412-000740	GRIP, HANDLE	1	
18		V804-000010	BOLT, TORX 4	11	TT-4*16 DG 10.9
19		V804-000180	BOLT, TORX 4	1	TT-P 4*20
20		V804-000060	BOLT, TORX 4	1	TB-4*16 10.9
21		V280-000000	NUT,WELD	1	M4
22		A047-000380	BOARD,ASM CONTROL	1	120A
23		A047-000391	SWITCH	1	
24		G334-001830	SWITCH	1	G33407S0080
25		J361-000760	LEVER	1	
26		V452-001780	SPRING,TORSION	1	
27		C490-000000	LOCKOUT	1	
28		V450-002250	SPRING,COMPRESSION	1	
29		V652-000250	GEAR,WORM	1	
30		P100-004610	CAP,OIL ASY	1	
31	+	900720-20029	O-RING	1	P-29
32	+	A365-000050	CONNECTOR,CAP	1	
33		P100-001900	STRAINER, OIL	1	
34		V471-002380	PIPE	1	
35		V186-000510	JOINT,PIPE	1	
36		X502-001060	LABEL,ECHO	1	
37		X543-005090	LABEL,MODEL	1	
38		X505-010220	LABEL,CAUTION	1	
39		V804-000170	BOLT, TORX 4	7	TT-P 4*16

CHAIN BRAKE

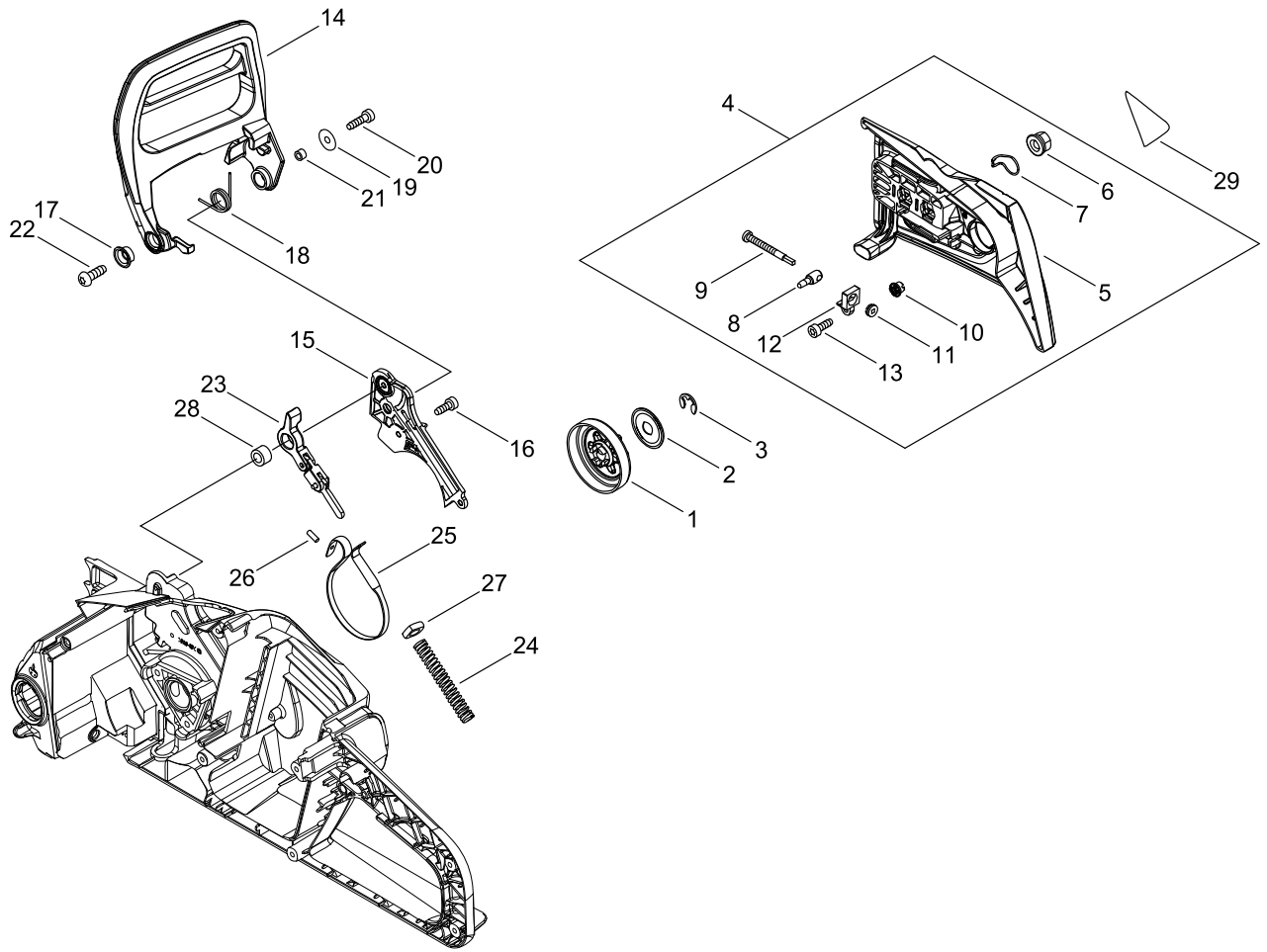

CHAIN BRAKE

Key No.	LV (+)	Part No	Description	Qty	Standard
1		A556-001800	DRUM, CLUTCH	1	3/8
2		V307-000520	WASHER,CIRCULAR 10	1	
3		V583-000440	RING	1	8.1 T1.2
4		P100-004491	GUARD, SPROCKET ASY	1	
5	+	C300-001170	GUARD, SPROCKET	1	
6	+	V265-000550	NUT,8	2	
7	+	C649-000420	HOOK	2	
8	+	C309-000030	TENSIONER,CHAIN	1	
9	+	V203-000041	BOLT,5	1	
10	+	V651-001060	GEAR,BEVEL	1	
11	+	V651-000011	GEAR,BEVEL	1	
12	+	V355-000900	COLLAR,8	1	
13	+	V804-000160	BOLT, TORX 4	1	TT-P ㌵ 4*12
14		C320-000542	LEVER, BRAKE	1	
15		C345-000670	COVER,BRAKE	1	
16		V804-000170	BOLT, TORX 4	3	TT-P ㌵ 4*16
17		V356-000430	COLLAR,10	1	
18		V452-000250	SPRING,TORSION	1	
19		177214-03930	WASHER	1	
20		V804-000180	BOLT, TORX 4	1	TT-P ㌵ 4*20
21		433116-35430	SPACER 8	1	8*12*9
22		V805-000010	BOLT, TORX 5	1	TT-5*20 DG 10.9
23		C334-000100	CONNECTOR, BRAKE	1	
24		V450-002240	SPRING,COMPRESSION	1	
25		C328-000340	BAND, BRAKE	1	
26		93050-30098	ROLLER	1	3*9.8
27		V376-000450	SPACER	1	
28		433116-35430	SPACER 8	1	8*12*9
29		X502-001070	LABEL,ECHO	1	

ACCESSORIES

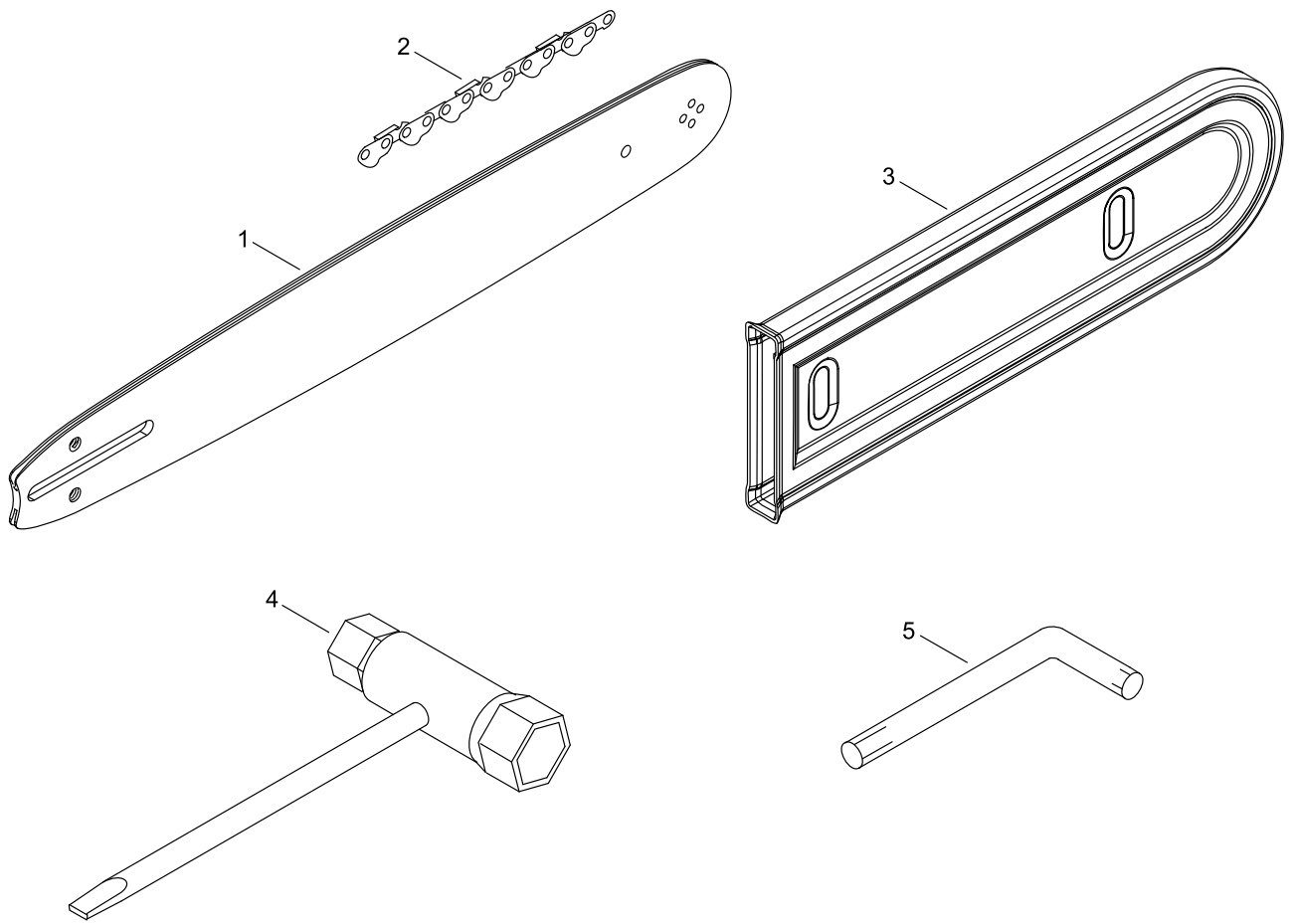

ACCESSORIES

Key No.	LV (+)	Part No	Description	Qty	Standard
1		X123-000231	BAR,GUIDE 35	1	C35S90-52SA-ET
2		X223-000150	CHAIN,SAW	1	90PX-52E
3		X490-000510	SCABBARD,CHAIN	1	
4		X602-000080	TOOL,WRENCH	1	13*19 L180
5		X605-000170	TOOL,L WRENCH	1	

NUMERICAL PARTS INDEX

Part No	Part description	Page	Part No	Part description	Page
132115-01461	GROMMET	2	V452-000250	SPRING,TORSION	4
177214-03930	WASHER	4	V452-001780	SPRING,TORSION	2
433116-35430	SPACER 8	4	V452-001790	SPRING,TORSION	2
900720-20029	O-RING	2	V470-002350	PIPE	2
93050-30098	ROLLER	4	V471-002380	PIPE	2
A047-000380	BOARD,ASM CONTROL	2	V583-000440	RING	4
A047-000391	SWITCH	2	V651-000011	GEAR,BEVEL	4
A054-000290	MOTOR,ASM	2	V651-001060	GEAR,BEVEL	4
A226-002180	ELEMENT, AIR FILTER	2	V652-000250	GEAR,WORM	2
A232-001960	LID,CLEANER	2	V804-000010	BOLT, TORX 4	2
A356-000130	VALVE,CHECK	2	V804-000060	BOLT, TORX 4	2
A365-000050	CONNECTOR,CAP	2	V804-000160	BOLT, TORX 4	4
A539-000440	COVER,MOTOR	2	V804-000170	BOLT, TORX 4	2
A556-001800	DRUM, CLUTCH	4	V804-000170	BOLT, TORX 4	4
C022-000072	AUTO-OILER ASSEMBLY	2	V804-000180	BOLT, TORX 4	2
C300-001170	GUARD, SPROCKET	4	V804-000180	BOLT, TORX 4	4
C309-000030	TENSIONER,CHAIN	4	V805-000010	BOLT, TORX 5	4
C320-000542	LEVER, BRAKE	4	V805-000160	BOLT, TORX 5	2
C328-000340	BAND, BRAKE	4	X123-000231	BAR,GUIDE 35	6
C334-000100	CONNECTOR, BRAKE	4	X223-000150	CHAIN,SAW	6
C345-000670	COVER,BRAKE	4	X490-000510	SCABBARD,CHAIN	6
C400-001650	HANDLE, FRONT	2	X502-001060	LABEL,ECHO	2
C412-000740	GRIP, HANDLE	2	X502-001070	LABEL,ECHO	4
C490-000000	LOCKOUT	2	X505-010220	LABEL,CAUTION	2
C649-000420	HOOK	4	X543-005090	LABEL,MODEL	2
E103-001520	CASE,FAN	2	X602-000080	TOOL,WRENCH	6
E103-001530	CASE,FAN	2	X605-000170	TOOL,L WRENCH	6
G334-001830	SWITCH	2			
J361-000760	LEVER	2			
J470-008660	COVER	2			
P100-001900	STRAINER, OIL	2			
P100-004470	COVER,MOTOR ASY	2			
P100-004491	GUARD, SPROCKET ASY	4			
P100-004610	CAP,OIL ASY	2			
V186-000510	JOINT,PIPE	2			
V203-000041	BOLT,5	4			
V225-000370	BOLT,STUD 8	2			
V265-000550	NUT,8	4			
V280-000000	NUT,WELD	2			
V307-000520	WASHER,CIRCULAR 10	4			
V355-000900	COLLAR,8	4			
V356-000430	COLLAR,10	4			
V376-000450	SPACER	4			
V450-002240	SPRING,COMPRESSION	4			
V450-002250	SPRING,COMPRESSION	2			