

shindaiwa[®]

PARTS CATALOGUE

BRUSHCUTTER 22C INTL

22C INTL

1. CYLINDER, MUFFLER

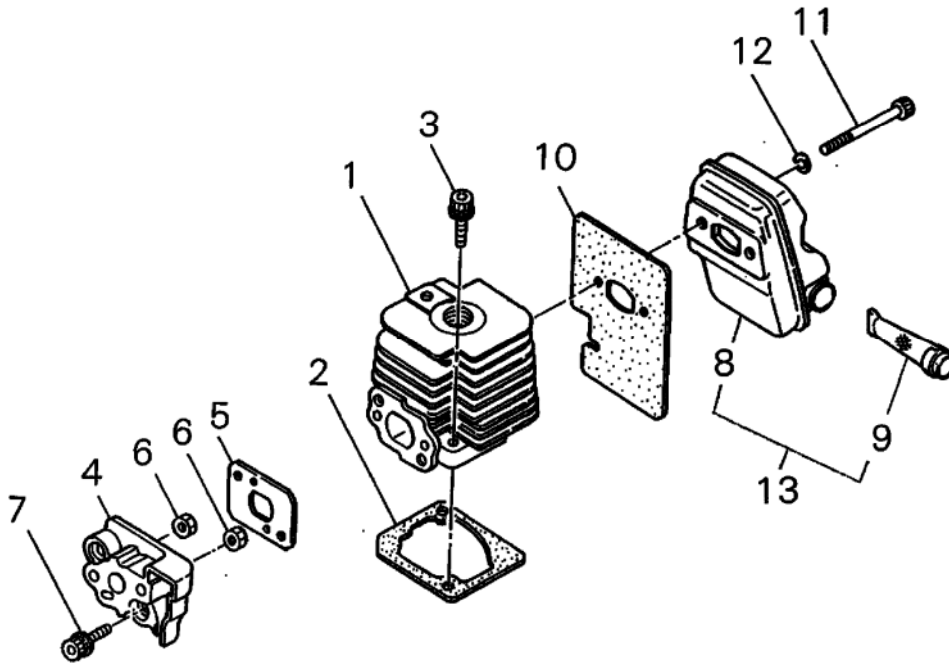

KEY	LV	PART NUMBER	Q'TY	DESCRIPTION	REMARKS	NOTE1	NOTE2
1		20142-12110	1	CYLINDER			
2		20016-12120	1	GASKET			
3		11022-05250	2	BOLT SPW		M5x25	
4		20140-12210	1	INSULATOR			
5		20140-12221	1	GASKET			
6		20011-12260	2	NUT			
7		11022-05250	2	BOLT SPW		M5x25	
13		67000-15010	1	MUFFLER ASSY			
8	·	67000-15110	1	MUFFLER			
9	·	67000-15340	1	SPARK ARRESTER			
10		20140-15120	1	GASKET			
11		01020-05400	2	BOLT		M5x40	
12		01610-05080	2	WASHER		5mm	

2. CRANKCASE, FAN COVER, CLUTCH DRUM

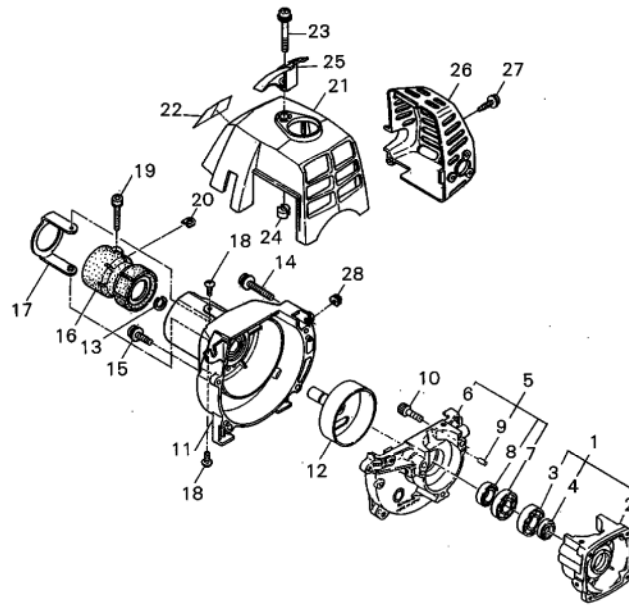

KEY	LV	PART NUMBER	Q'TY	DESCRIPTION	REMARKS	NOTE1	NOTE2
1		20035-21101	1	CRANK CASE S COMP			
2	•	20036-21112	1	CRANK CASE S			
3	•	12900-60010	1	BALL BEARING			
4	•	22150-21250	1	SEAL,OIL			
5		20140-21201	1	CRANK CASE M COMP			
6	•	20036-21124	1	CRANK CASE M			
7	•	12900-60010	1	BALL BEARING			
8	•	20000-21211	1	OIL SEAL			
9	•	12492-40080	2	ROLLER		E4X8F6 C3	
10		01020-05250	3	BOLT		M5x25	
11		20142-31113	1	FAN COVER			
12		20016-31212	1	CLUTCH DRUM			
13		20000-31140	1	SNAP RING			
14		11206-05300	3	SCREW PM SPW		M5x30	
15		11206-05160	1	SCREW PM SPW		M5x16	
16		20087-31411	1	JOINT			
17		20142-31420	1	STOPPER			
18		11260-04081	2	SCREW ADHESIVE		M4x8	
19		11020-05220	1	BOLT-SW		M5x22	
21		20140-32112	1	CYLINDER COVER			
22		62038-91020	1	LABEL TRADE			
23		20140-31250	1	SCREW PM SLPW			
24		20140-31260	1	INSULATOR			
25		20140-34112	1	PROTECTOR			
26		20142-32211	1	MUFFLER COVER			
27		22160-32210	1	SCREW PC			

2. CRANKCASE, FAN COVER, CLUTCH DRUM

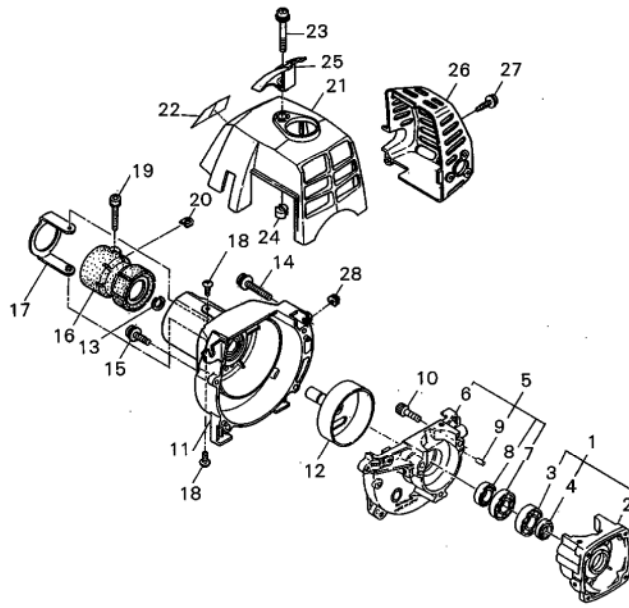

KEY	LV	PART NUMBER	Q'TY	DESCRIPTION	REMARKS	NOTE1	NOTE2
28		20011-72120	1	GROMMET			

3. CRANKSHAFT, PISTON, CLUTCH SHOE

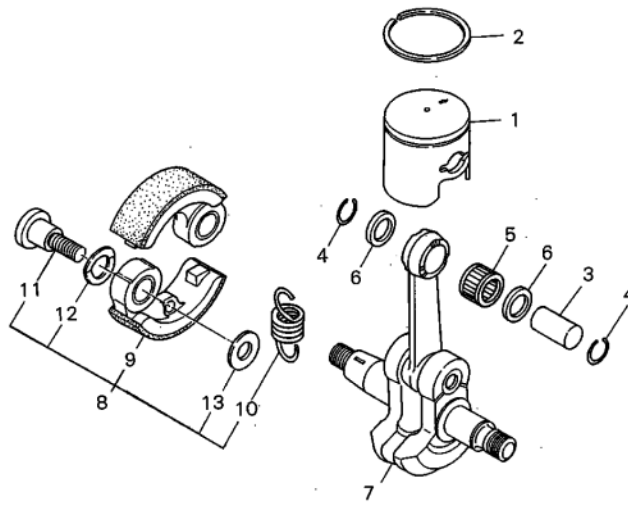

KEY	LV	PART NUMBER	Q'TY	DESCRIPTION	REMARKS	NOTE1	NOTE2
1		20142-41111	1	PISTON			
2		20142-41210	1	PISTON RING			
3		20142-41310	1	PISTON PIN			
4		70030-41320	2	RING,END			
5		67000-41230	1	NEEDLE BEARING			
6		20016-41340	2	THRUST WASHER			
7		67000-42010	1	CRANK SHAFT			
8		67000-51011	1	CLUTCH SHOE SET			
9	•	20035-51111	2	CLUTCH SHOE			
10	•	20035-51221	1	CLUTCH SPRING			
11	•	20142-51210	2	BOLT			
12	•	20087-51231	2	SPRING PLATE			
13	•	22100-71430	2	WASHER			

4. COIL, ROTOR

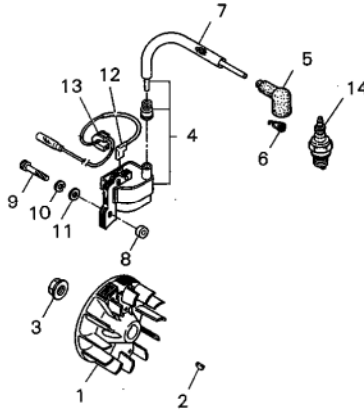

KEY	LV	PART NUMBER	Q'TY	DESCRIPTION	REMARKS	NOTE1	NOTE2
1		20140-71200	1	ROTOR			
2		02403-03100	1	KEY	3*10	3x10	
3		20035-71220	1	NUT		M8 MFZN3-C	
4		20140-71600	1	COIL ASSY			
5		70223-72200	1	PLUG CAP COMP			
6		20000-72230	1	SPRING SPARK PLUG			
7		70064-72111	1	TUBE			
8		70030-71620	2	INSULATOR			
9		11024-04261	2	BOLT		M4x26-12.9	
12		67000-71240	1	CORD			
13		20011-72120	1	GROMMET			
14		13000-13406	1	SPARK PLUG BMR6A		BMR6A	

5. RECOIL STARTER

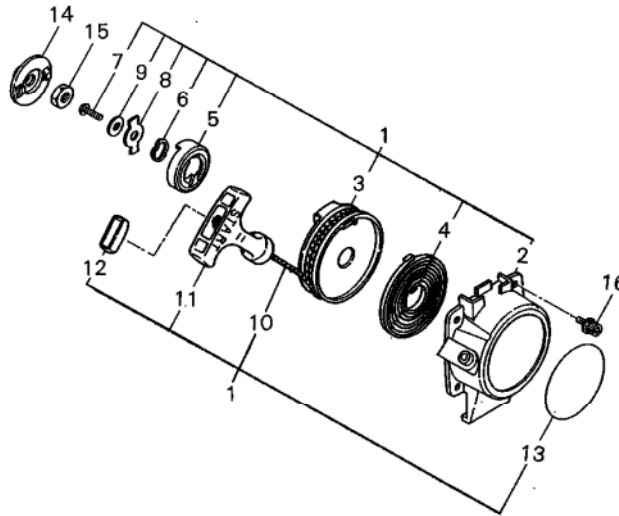

KEY	LV	PART NUMBER	Q'TY	DESCRIPTION	REMARKS	NOTE1	NOTE2
1		20140-75900	1	RECOIL STARETR			
2	•	20140-75110	1	STARTER CASE			
3	•	20140-75120	1	REEL			
4	•	20140-75130	1	SPRING			
5	•	20140-75140	1	DOG			
6	•	20140-75150	1	BRAKE SPRING			
7	•	20140-75160	1	SCREW			
8	•	20140-75170	1	RETAINER			
9	•	20140-75180	1	WASHER			
10	•	70064-75190	1	ROPE			
11	•	70064-75211	1	HANDLE			
12	•	70064-75220	1	STOPPER			
13		62038-91030	1	NAME PLATE			
14		20140-75310	1	STARTER PULLEY			
15		01511-08051	1	NUT		M8	
16		11024-04120	4	BOLT SPW		M4x12	

6. CARBURETOR, CLEANER

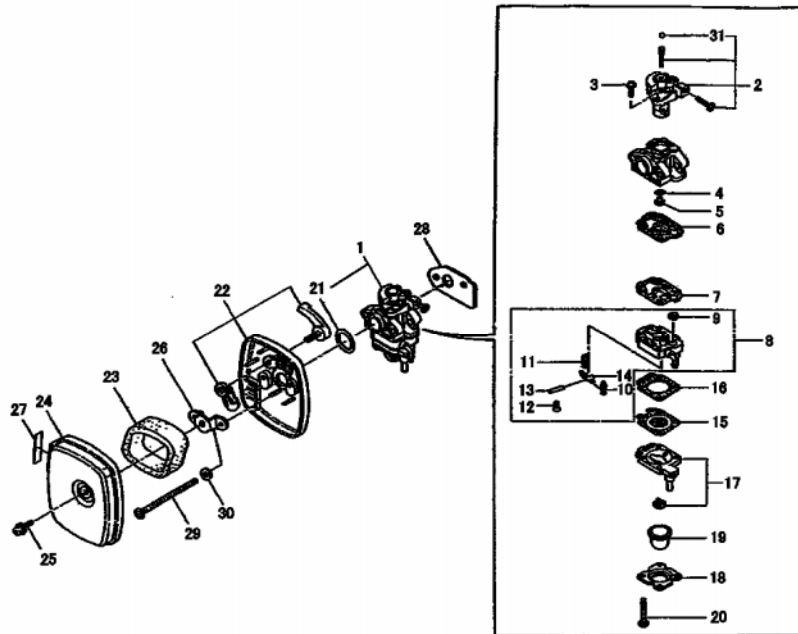

KEY	LV	PART NUMBER	Q'TY	DESCRIPTION	REMARKS	NOTE1	NOTE2
1		67000-81010	1	CARBURETOR ASSY			
2	•	20016-81180	1	VALVE ASSY			
31	•	62074-81320	1	PLAG			
3	•	70064-81290	2	SCREW	M3*10		
4	•	70097-81220	1	O-RING			
5	•	67000-81330	1	MAIN JET			
6	•	70097-81310	1	GASKET,PUMP			
7	•	70097-81320	1	DIAPHRAGM			
8	•	72933-81410	1	PUMP BODY ASSY			
9	• •	70030-81380	1	SCREEN			
10	• •	20036-81440	1	VALVE			
11	• •	72933-81270	1	SPRING			
12	• •	20016-81450	1	SCREW			
13	• •	22100-81250	1	PIN			
14	• •	22100-81230	1	LEVER, METERING			
15	•	22100-81260	1	DIAPHRAGM ASM			
16	•	20016-81280	1	GASKET			
17	•	20016-81420	1	PUMP BASE COMP			
18	•	20016-81510	1	PUMP COVER			
19	•	20036-81670	1	PRIMER PUMP			
20	•	20016-81140	1	SCREW			
21	•	20016-81250	1	O RING			
22		20140-81700	1	CLEANER BODY			
23		20140-82210	1	FILTER			
24		20140-81790	1	CLEANER COVER			
25		37019-82340	1	SCREW PM SLPW			

6. CARBURETOR, CLEANER

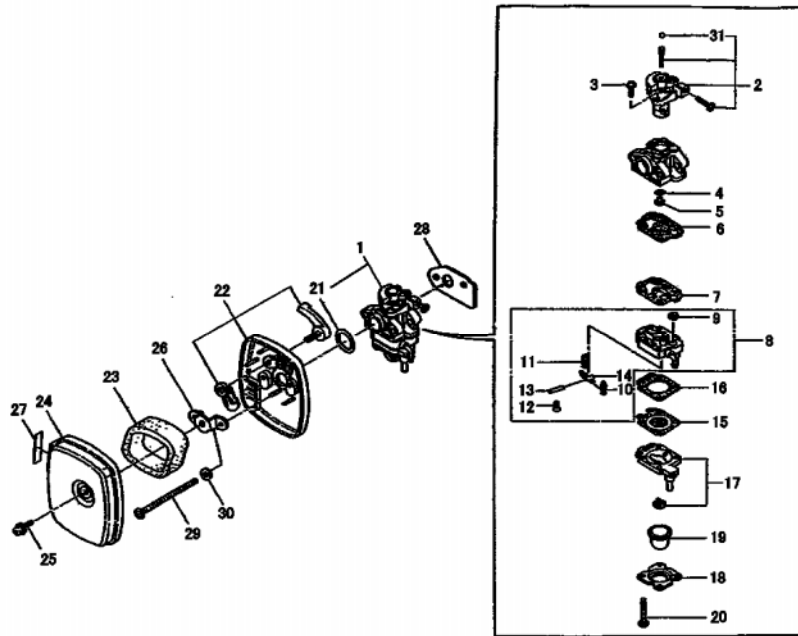

KEY	LV	PART NUMBER	Q'TY	DESCRIPTION	REMARKS	NOTE1	NOTE2
26		20018-81721	1	BACK PLATE			
27		19404-00008	1	LABEL CHOKE			
28		20140-81350	1	GASKET			
29		11203-05658	2	SCREW PM		M5x65	
30		01610-05080	2	WASHER		5mm	

7. FUEL TANK

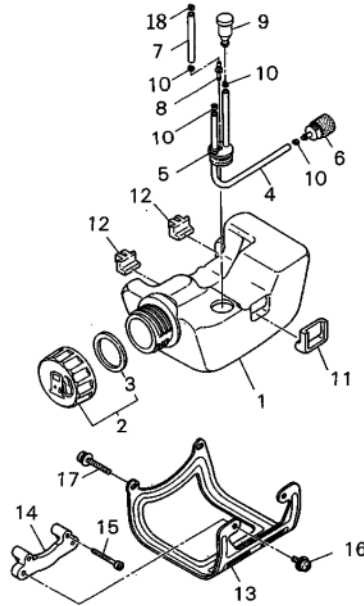

KEY	LV	PART NUMBER	Q'TY	DESCRIPTION	REMARKS	NOTE1	NOTE2
1		20142-85113	1	FUEL TANK			
2		70043-85201	1	FUEL CAP SUB ASSY			
3		20000-85221	1	GASKET			
4		20140-85310	1	FUEL PIPE			
6		20016-85400	1	FUEL FILTER			
7		20112-85361	1	PIPE			
8		72933-85620	1	JOINT			
9		20035-85522	1	VALVE			
10		20020-85540	4	CLIP			
11		20087-86130	1	TANK CUSHION			
12		20087-86141	2	TANK CUSHION			
13		62902-85320	1	TANK GUARD			
14		67000-86310	1	BRACKET			
15		11024-04300	2	BOLT SW		M4x30	
16		11206-05180	2	SCREW PM		M5x18	
17		11206-05350	2	SCREW PM SPW		M5x35	
18		37013-85310	1	CLIP			

8. OUTER PIPE

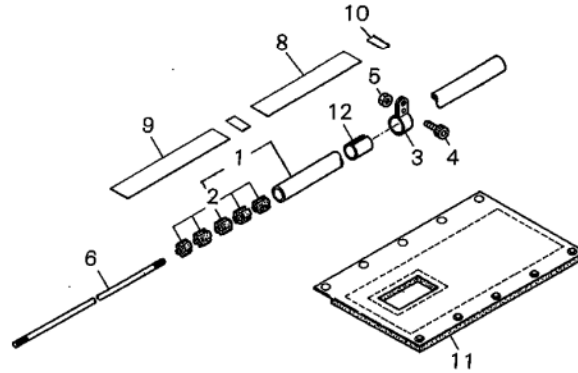

KEY	LV	PART NUMBER	Q'TY	DESCRIPTION	REMARKS	NOTE1	NOTE2
1		22554-12101	1	OUTER PIPE COMP			
2		22410-12120	5	BUSH			
3		22410-12210	1	HANGER			
4		01020-05120	1	BOLT	M5*12	M5x12	
5		01500-05041	1	NUT	M5	M5	
6		22070-12410	1	MAIN SHAFT			
8		19422-00022	1	LABEL CAUTION			
9		63022-91010	1	LABEL TRADE			
10		72005-12140	1	CAUTION PLATE			
11		22057-17110	1	PROTECTOR			

9. GEAR CASE

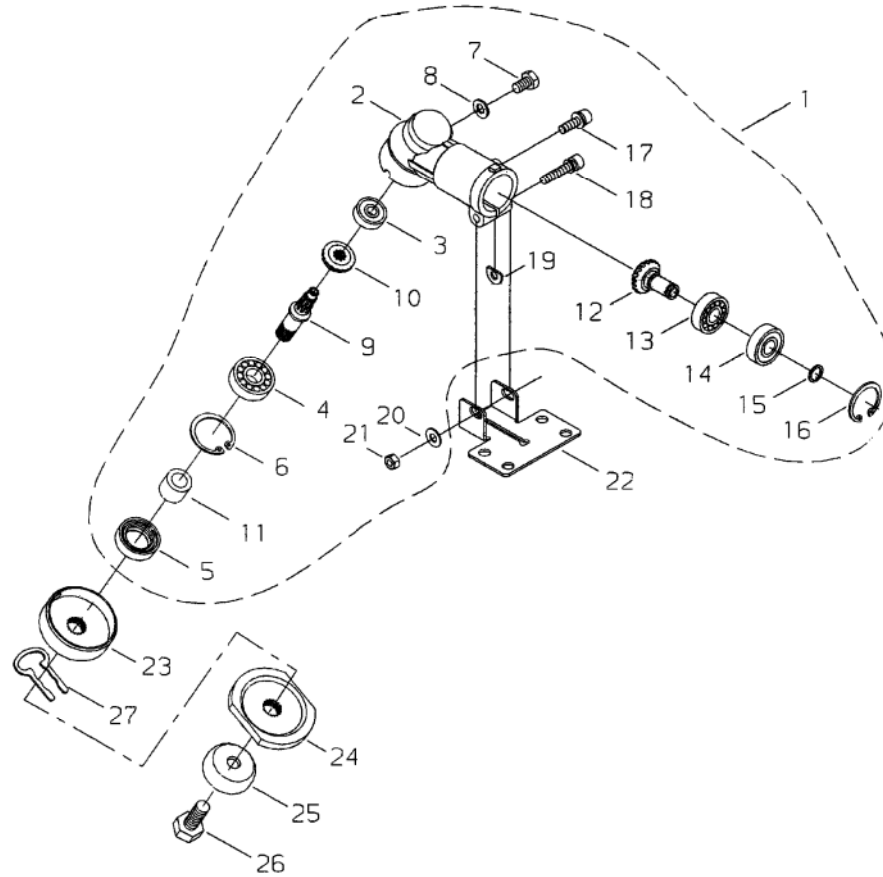

KEY	LV	PART NUMBER	Q'TY	DESCRIPTION	REMARKS	NOTE1	NOTE2
1		63901-63022	1	GEAR CASE SUB ASSY			
2	•	22035-13113	1	GEAR CASE			
3	•	02006-00626	1	BEARING			
4	•	02000-06000	1	BEARING			
5	•	22035-13140	1	OIL SEAL			
6	•	02432-26120	1	SNAP RING		26mm	
7	•	01014-06100	1	BOLT		M6x10	
8	•	22000-13410	1	GASKET			
9	•	22410-13210	1	GEAR SHAFT			
10	•	22035-13220	1	BEVEL GEAR			
11	•	22035-13230	1	COLLAR			
12	•	22035-13391	1	PINION SET			
13	•	02000-00608	1	BEARING		608	
14	•	02002-00608	1	BEARING	608ZZ	608ZZ	
15	•	22035-13340	1	SNAP RING			
16	•	02432-22100	1	SNAP RING		22mm	
17	•	11022-05160	1	BOLT SPW		M5x16	
18	•	11022-05350	1	BOLT SPW		M5x35	
19	•	22000-13420	1	SHIM			
20	•	01613-05080	1	WASHER		5mm	
21	•	01500-05041	1	NUT	M5	M5	
22		72480-16130	1	LOWER CLAMP			
23		22035-13242	1	HOLDER A			
24		22410-13251	1	HOLDER B			
25		22035-13290	1	BOLT GUARD			
26		22035-13271	1	BOLT			

9. GEAR CASE

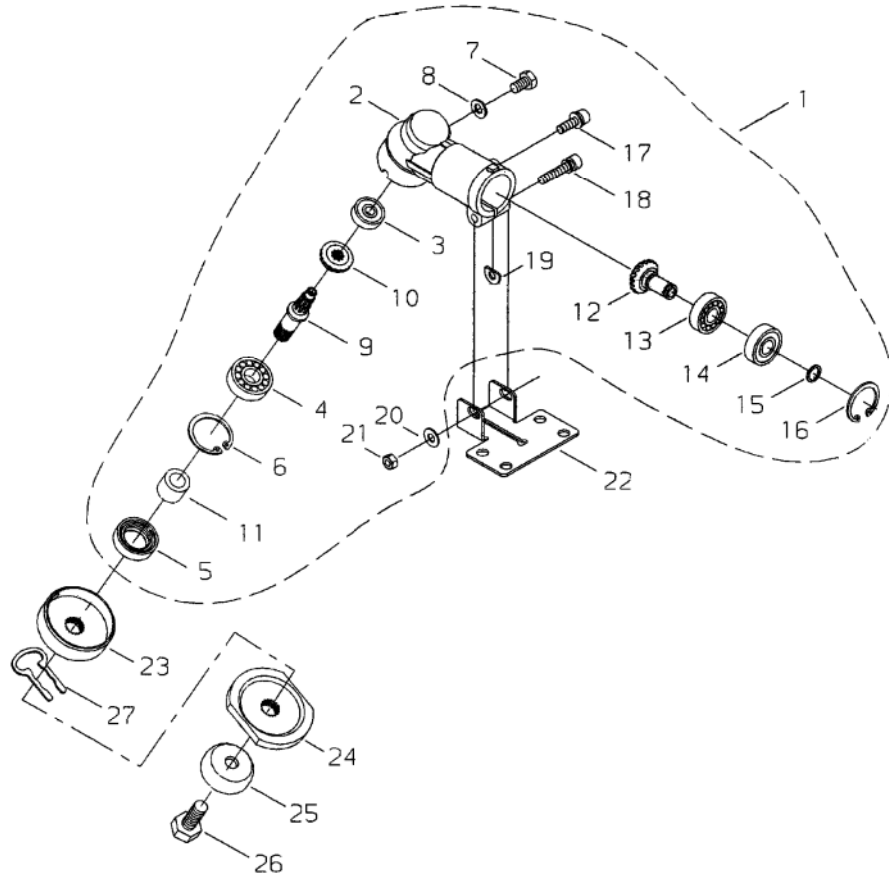

KEY	LV	PART NUMBER	Q'TY	DESCRIPTION	REMARKS	NOTE1	NOTE2
27		22410-13530	1	SLIDE CLIP			

10. TOOL

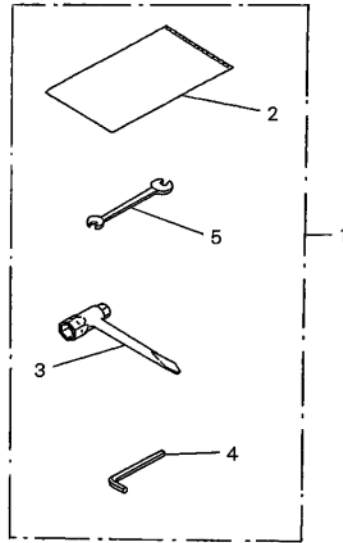

KEY	LV	PART NUMBER	Q'TY	DESCRIPTION	REMARKS	NOTE1	NOTE2
1		22410-91000	1	TOOL SET			
2	•	19639-01400	1	BAG,PACKING	140*200*T0.08		
3	•	22000-91181	1	PLUG WRENCH		13x19mm	
4	•	09026-04001	1	HEXA WRENCH	4MM M5	4mm M5	
5	•	22000-91120	1	SPANNER			

11. HANDLE THROTTLE LEVER

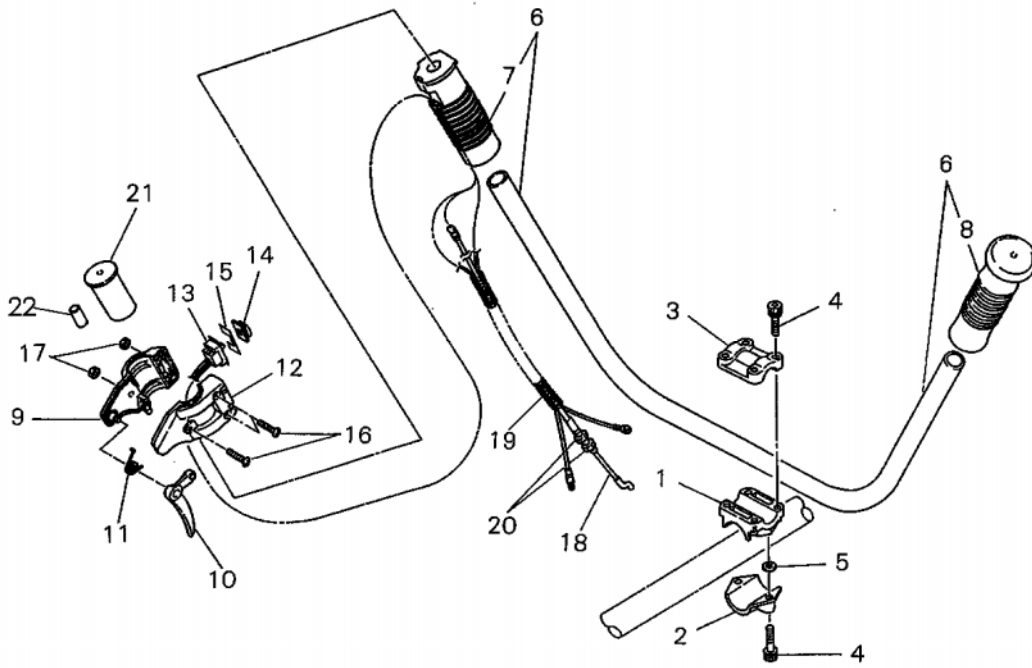

KEY	LV	PART NUMBER	Q'TY	DESCRIPTION	REMARKS	NOTE1	NOTE2
23		34004-64020	1	BRACKET ASSY			
1	▪	34004-64110	1	BRACKET			
2	▪	34004-64120	1	LOWER CAP			
3	▪	34004-64130	1	UPPER CAP			
4	▪	11022-05250	6	BOLT SPW		M5x25	
5	▪	01610-05080	1	WASHER		5mm	
6		72481-14200	1	HANDLE SUB ASSY			
7	▪	22421-14220	1	GRIP			
8	▪	22421-14230	1	GRIP			
24		22411-14302	1	THROTTLE LEVER ASSY			
9	▪	22410-14312	1	BRACKET RIGHT			
10	▪	22410-14321	1	LEVER			
11	▪	22410-14331	1	SPRING			
12	▪	22410-14341	1	BRACKET LEFT			
13	▪	22411-14351	1	SWITCH COMP			
14	▪	22420-12930	1	KNOB			
15	▪	22420-12940	1	PLATE			
16	▪	11206-05300	3	SCREW PM SPW		M5x30	
17	▪	01501-05031	3	NUT		M5	
25		22411-14500	1	CABLE ASSY			
18	▪	22411-14511	1	THROTTLE CABLE			
19	▪	22421-14540	1	TUBE			
20	▪	01501-06041	2	NUT	M6	M6	
21		22411-14611	1	SPACER			
22		22411-14550	1	PIPE			

12. GUARD, STRAP

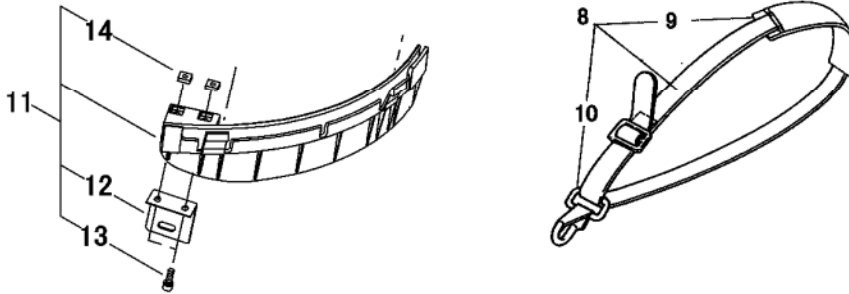

KEY	LV	PART NUMBER	Q'TY	DESCRIPTION	REMARKS	NOTE1	NOTE2
8		22410-17202	1	STRAP ASSY			
9	•	22007-17220	1	PROTECTOR			
10		62903-66111	1	GUARD			
11		62903-66332	1	SUB GUARD ASSY			
12	•	72480-16121	1	CUTTER			
13	•	11020-05160	2	BOLT SW		M5x16	
14	•	22420-16120	2	NUT			

Index

Patrs Number	Key No.	Patrs Number	Key No.	Patrs Number	Key No.
01014-06100	9 - 7	20011-12260	1 - 6	20140-75900	5 - 1
01020-05120	8 - 4	20011-72120	2 - 28	20140-81350	6 - 28
01020-05250	2 - 10	20011-72120	4 - 13	20140-81700	6 - 22
01020-05400	1 - 11	20016-12120	1 - 2	20140-81790	6 - 24
01500-05041	8 - 5	20016-31212	2 - 12	20140-82210	6 - 23
01500-05041	9 - 21	20016-41340	3 - 6	20140-85310	7 - 4
01501-05031	11 - 17	20016-81140	6 - 20	20142-12110	1 - 1
01501-06041	11 - 20	20016-81180	6 - 2	20142-31113	2 - 11
01511-08051	5 - 15	20016-81250	6 - 21	20142-31420	2 - 17
01610-05080	1 - 12	20016-81280	6 - 16	20142-32211	2 - 26
01610-05080	6 - 30	20016-81420	6 - 17	20142-41111	3 - 1
01610-05080	11 - 5	20016-81450	6 - 12	20142-41210	3 - 2
01613-05080	9 - 20	20016-81510	6 - 18	20142-41310	3 - 3
02000-00608	9 - 13	20016-85400	7 - 6	20142-51210	3 - 11
02000-06000	9 - 4	20018-81721	6 - 26	20142-85113	7 - 1
02002-00608	9 - 14	20020-85540	7 - 10	22000-13410	9 - 8
02006-00626	9 - 3	20035-21101	2 - 1	22000-13420	9 - 19
02403-03100	4 - 2	20035-51111	3 - 9	22000-91120	10 - 5
02432-22100	9 - 16	20035-51221	3 - 10	22000-91181	10 - 3
02432-26120	9 - 6	20035-71220	4 - 3	22007-17220	12 - 9
09026-04001	10 - 4	20035-85522	7 - 9	22035-13113	9 - 2
11020-05160	12 - 13	20036-21112	2 - 2	22035-13140	9 - 5
11020-05220	2 - 19	20036-21124	2 - 6	22035-13220	9 - 10
11022-05160	9 - 17	20036-81440	6 - 10	22035-13230	9 - 11
11022-05250	1 - 3	20036-81670	6 - 19	22035-13242	9 - 23
11022-05250	1 - 7	20087-31411	2 - 16	22035-13271	9 - 26
11022-05250	11 - 4	20087-51231	3 - 12	22035-13290	9 - 25
11022-05350	9 - 18	20087-86130	7 - 11	22035-13340	9 - 15
11024-04120	5 - 16	20087-86141	7 - 12	22035-13391	9 - 12
11024-04261	4 - 9	20112-85361	7 - 7	22057-17110	8 - 11
11024-04300	7 - 15	20140-12210	1 - 4	22070-12410	8 - 6
11203-05658	6 - 29	20140-12221	1 - 5	22100-71430	3 - 13
11206-05160	2 - 15	20140-15120	1 - 10	22100-81230	6 - 14
11206-05180	7 - 16	20140-21201	2 - 5	22100-81250	6 - 13
11206-05300	2 - 14	20140-31250	2 - 23	22100-81260	6 - 15
11206-05300	11 - 16	20140-31260	2 - 24	22150-21250	2 - 4
11206-05350	7 - 17	20140-32112	2 - 21	22160-32210	2 - 27
11260-04081	2 - 18	20140-34112	2 - 25	22410-12120	8 - 2
12492-40080	2 - 9	20140-71200	4 - 1	22410-12210	8 - 3
12900-60010	2 - 3	20140-71600	4 - 4	22410-13210	9 - 9
12900-60010	2 - 7	20140-75110	5 - 2	22410-13251	9 - 24
13000-13406	4 - 14	20140-75120	5 - 3	22410-13530	9 - 27
19404-00008	6 - 27	20140-75130	5 - 4	22410-14312	11 - 9
19422-00022	8 - 8	20140-75140	5 - 5	22410-14321	11 - 10
19639-01400	10 - 2	20140-75150	5 - 6	22410-14331	11 - 11
20000-21211	2 - 8	20140-75160	5 - 7	22410-14341	11 - 12
20000-31140	2 - 13	20140-75170	5 - 8	22410-17202	12 - 8
20000-72230	4 - 6	20140-75180	5 - 9	22410-91000	10 - 1
20000-85221	7 - 3	20140-75310	5 - 14	22411-14302	11 - 24

Index

Patrs Number	Key No.	Patrs Number	Key No.	Patrs Number	Key No.
22411-14351	11 - 13	72005-12140	8 - 10		
22411-14500	11 - 25	72480-16121	12 - 12		
22411-14511	11 - 18	72480-16130	9 - 22		
22411-14550	11 - 22	72481-14200	11 - 6		
22411-14611	11 - 21	72933-81270	6 - 11		
22420-12930	11 - 14	72933-81410	6 - 8		
22420-12940	11 - 15	72933-85620	7 - 8		
22420-16120	12 - 14				
22421-14220	11 - 7				
22421-14230	11 - 8				
22421-14540	11 - 19				
22554-12101	8 - 1				
34004-64020	11 - 23				
34004-64110	11 - 1				
34004-64120	11 - 2				
34004-64130	11 - 3				
37013-85310	7 - 18				
37019-82340	6 - 25				
62038-91020	2 - 22				
62038-91030	5 - 13				
62074-81320	6 - 31				
62902-85320	7 - 13				
62903-66111	12 - 10				
62903-66332	12 - 11				
63022-91010	8 - 9				
63901-63022	9 - 1				
67000-15010	1 - 13				
67000-15110	1 - 8				
67000-15340	1 - 9				
67000-41230	3 - 5				
67000-42010	3 - 7				
67000-51011	3 - 8				
67000-71240	4 - 12				
67000-81010	6 - 1				
67000-81330	6 - 5				
67000-86310	7 - 14				
70030-41320	3 - 4				
70030-71620	4 - 8				
70030-81380	6 - 9				
70043-85201	7 - 2				
70064-72111	4 - 7				
70064-75190	5 - 10				
70064-75211	5 - 11				
70064-75220	5 - 12				
70064-81290	6 - 3				
70097-81220	6 - 4				
70097-81310	6 - 6				
70097-81320	6 - 7				
70223-72200	4 - 5				

YAMABIKO CORPORATION

7-2 SUEHIROCHO 1-CHOME, OHME, TOKYO 198-8760, JAPAN
PHONE: 81-428-32-6118. FAX: 81-428-32-6145.

shindaiwa[®]

INTL
No.