



PARTS CATALOGUE

GRASS-TRIMMER / BRUSHCUTTER

SRM-3805

1. Cylinder, Crankcase, Piston, Fan Cover

No.1

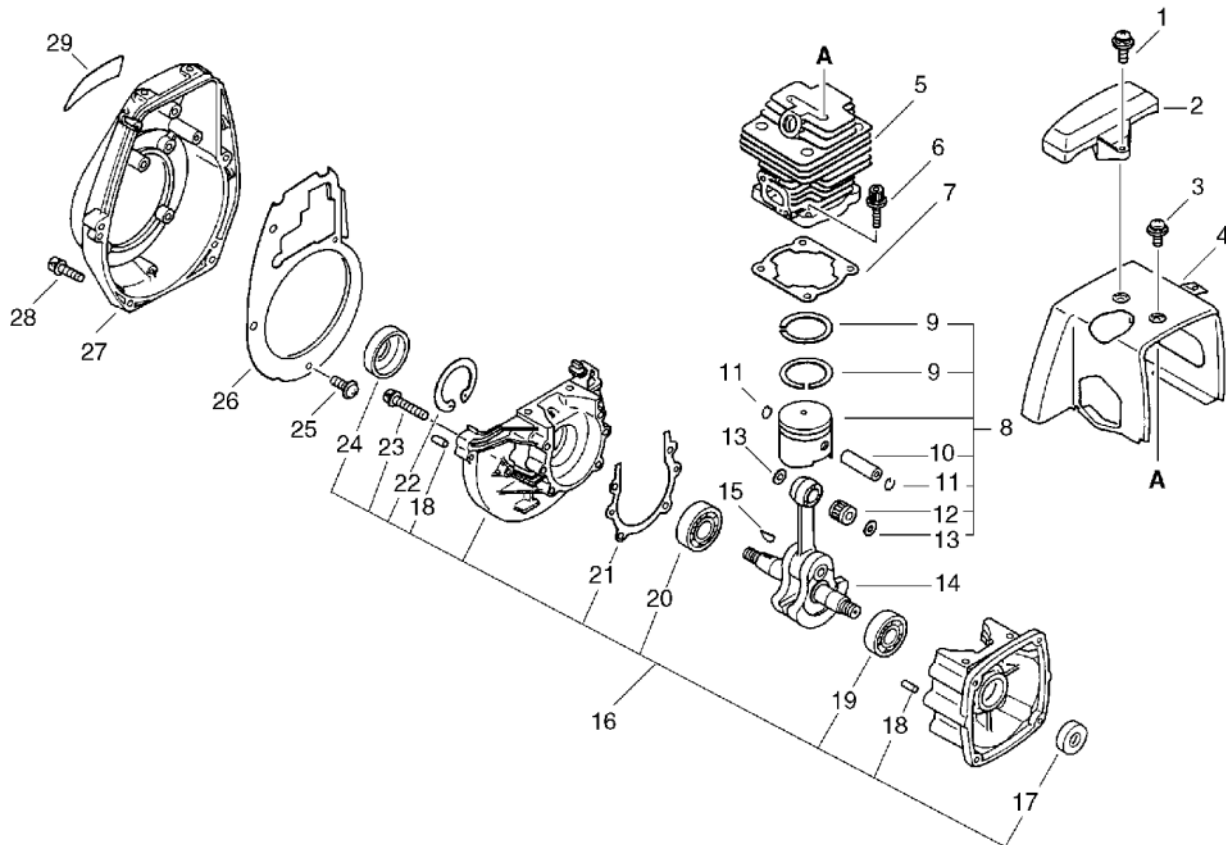

KEY	LV	PART NUMBER	Q'TY	DESCRIPTION	REMARKS	NOTE1	NOTE2
1		900238-05014	3	SCREW 5*14	5*14		
2		159905-43130	1	GUARD, TOP			
3		900238-05010	1	SCREW 5*10	5*10		
4		101514-42230	1	COVER, CYLINDER (BS)			
5		101011-43130	1	CYLINDER			
6		900162-05020	4	BOLT, H.S. 5*20	5*20 W,SW		
7		101010-42231	1	GASKET, CYL. BASE			
8		100000-43130	1	PISTON KIT		Sus. by 100000-43131	
8		100000-43131	1	PISTON KIT			
9	+	100011-42230	2	RING, PISTON			
10	+	100013-00410	1	PIN, PISTON	6*10*29.8		
11	+	100015-00120	2	CIRCLIP, PISTON PIN			
12	+	100012-27930	1	BEARING, NEEDLE		Sus. by 100012-12331	
12	+	100012-12331	1	BEARING, NEEDLE			
13	+	100014-17330	2	SPACER, PISTON PIN		Sus. by V307-000050	
13	+	V307-000050	2	WASHER,CIRCULAR 10			
14		100100-43130	1	CRANKSHAFT ASSY			
15		100142-12330	1	KEY, WOODRUFF			
16		100204-42230	1	CRANKCASE KIT			
17	+	100212-27930	1	OILSEAL	ISD 12 25 7		
18	+	100215-02830	4	PIN, DOWEL			
19	+	900810-36201	1	BEARING, BALL 6201	6201/C3	Sus. by 94035-36201	

1. Cylinder, Crankcase, Piston, Fan Cover

No.1

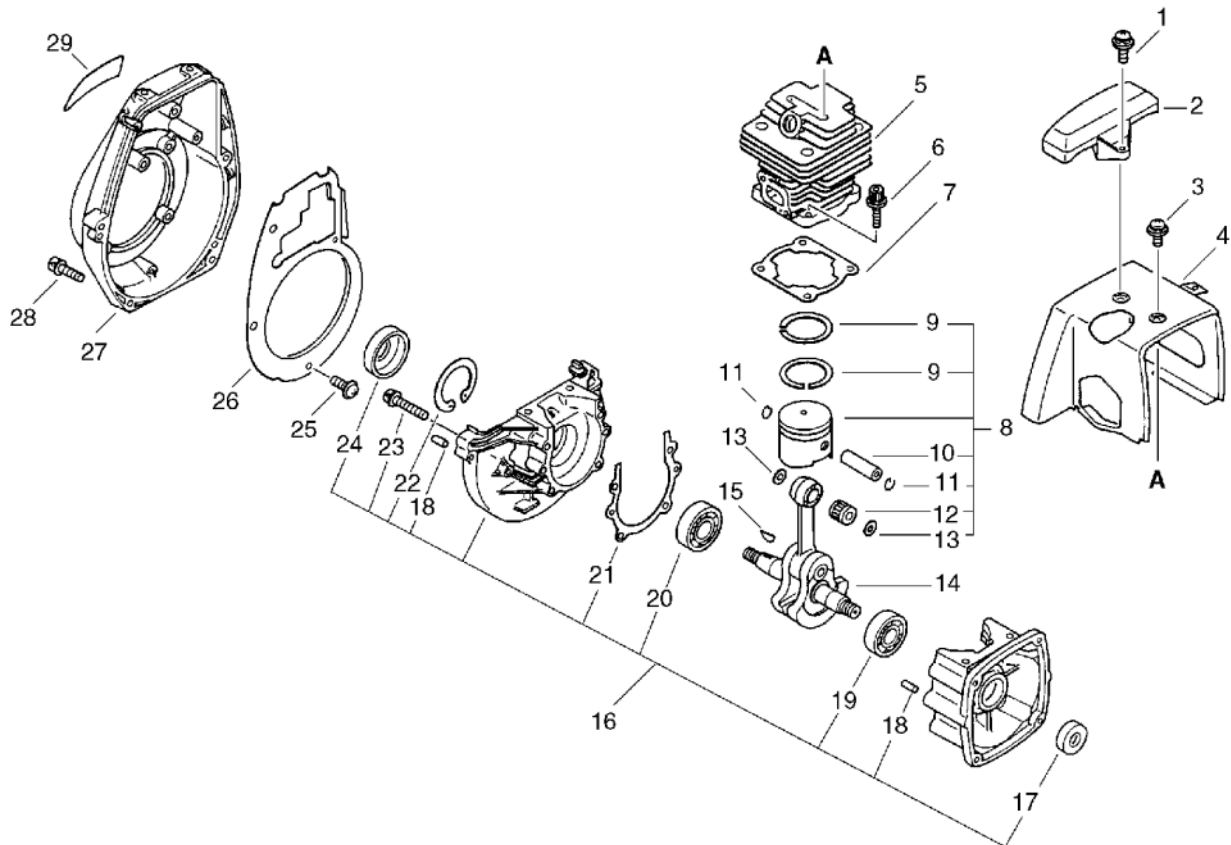

KEY	LV	PART NUMBER	Q'TY	DESCRIPTION	REMARKS	NOTE1	NOTE2
19	+	94035-36201	1	BEARING BALL	6201X3JR2C3		
20	+	900810-36202	1	BEARING, BALL 6202	6202/C3		
21	+	100242-42230	1	GASKET, CRANKCASE			
22	+	900702-00035	1	CIRCLIP 35	CR-35		
23	+	900162-05030	4	BOLT, H.S. 5*30	5*30 W,SW		
24	+	100213-02830	1	OILSEAL	ISMX15,35,6		
25		900238-04010	4	SCREW 4*10	4*10		
26		101534-42230	1	PLATE, GUIDE			
27		101511-42230	1	COVER, FAN (BS)			
28		900162-05025	4	BOLT, H.S. 5*25	5*25 W,SW		
29		890611-43030	1	LABEL, MODEL			

2. Starter

No.2

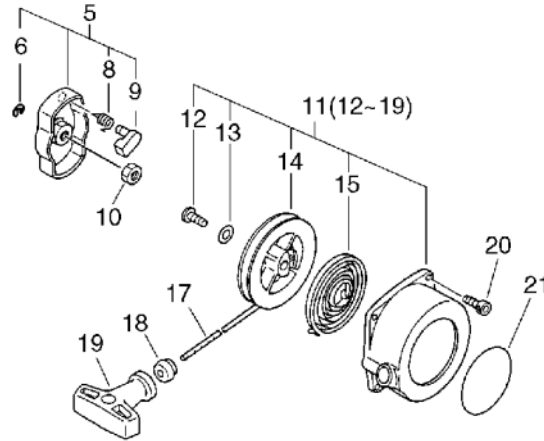

KEY	LV	PART NUMBER	Q'TY	DESCRIPTION	REMARKS	NOTE1	NOTE2
5		177202-41030	1	PAWL ASSY, STARTER			
6	+	900700-00004	1	E-RING 4	CE-4		
8	+	177234-40630	1	SPRING, RETURN			
9	+	177218-40630	1	PAWL, STARTER	WHITE		
10		900502-00008	1	NUT 8 (3N)	3N8		
11		177200-43130	1	STARTER ASSY (BS)		Sus. by A051-000170	
11		A051-000170	1	STARTER, RECOIL			
12	+	177236-40630	1	SCREW			
13	+	177214-41030	1	WASHER			
14	+	177215-43130	1	DRUM, STARTER			
15	+	177220-40630	1	SPRING, REWIND			
17	+	177226-01110	1	ROPE, STARTER	4.0*880		
18	+	177227-05530	1	GUIDE, ROPE		Sus. by 177227-42030	
18	+	177227-42030	1	GUIDE, ROPE			
19	+	177228-11120	1	GRIP, STARTER			
20		900162-04020	4	BOLT, H.S. 4*20	4*20 W,SW		
21		890118-49330	1	LABEL, ECHO			

3. Magneto, Clutch

No.3

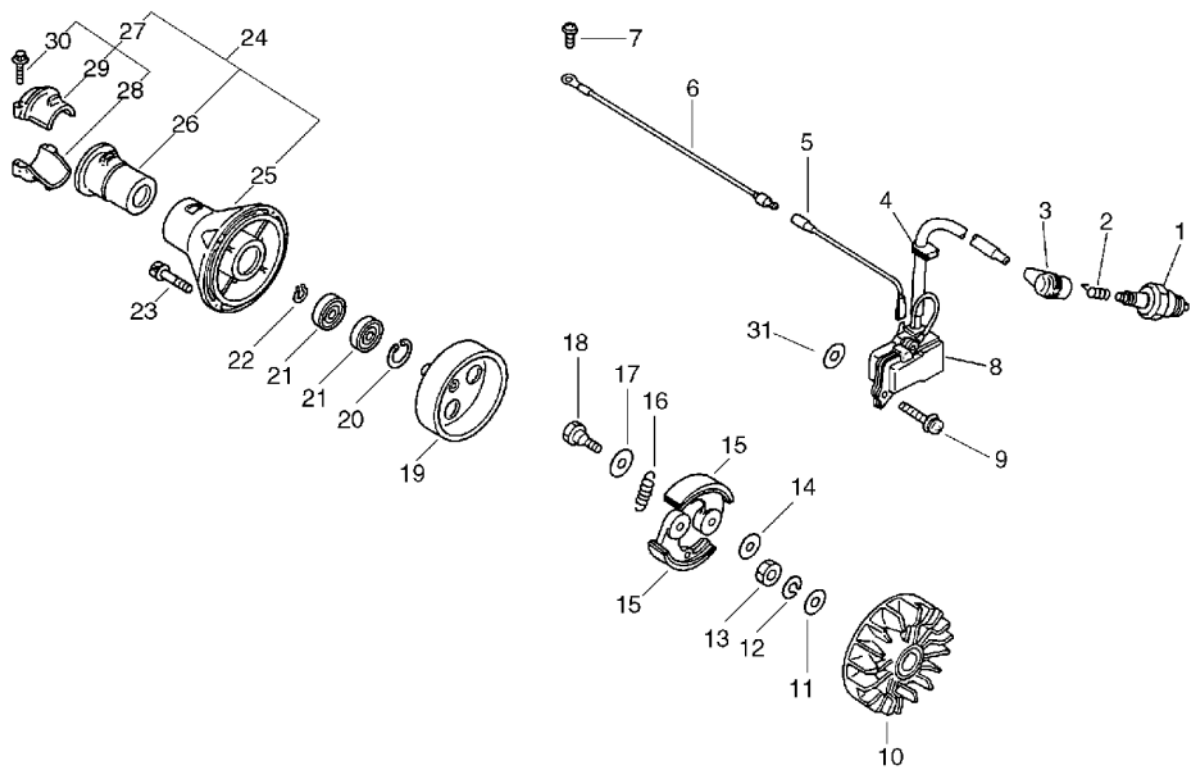

KEY	LV	PART NUMBER	Q'TY	DESCRIPTION	REMARKS	NOTE1	NOTE2
1		159017-10230	1	PLUG, SPARK (RCJ-7Y)	RCJ-7Y		
2		159011-03432	1	COIL, SPARK PLUG			
3		159012-03433	1	CAP, SPARK PLUG			
4		156112-40630	1	GROMMET			
5		162021-42230	1	LEAD			
6		156635-43130	1	LEAD, GROUND			
7		900238-05010	1	SCREW 5*10	5*10		
8		156626-42230	1	COIL, IGNITION		Sus. by set of 156601-12920 and 900600-00006	
8		156601-12920	1	COIL,IGNITION			
9		900238-05020	2	SCREW 5*20	5*20		
10		156801-42230	1	FLYWHEEL			
11		900600-00010	1	WASHER 10	10		
12		900605-00010	1	WASHER, SPRING 10	10		
13		900503-00010	1	NUT 10 (3N *1.25)	3N10*P1.25		
14		175049-03920	2	WASHER			
15		175009-42231	2	SHOE, CLUTCH			
16		175018-42230	1	SPRING, CLUTCH			
17		175048-03920	2	WASHER			
18		175046-06230	2	BOLT, CLUTCH			
19		175005-43130	1	DRUM, CLUTCH			
20		900702-00028	1	CIRCLIP 28	CR-28		
21		900807-06001	2	BEARING, BALL 6001	6001V(LB)		
22		900701-00012	1	CIRCLIP 12	CS-12		

3. Magneto, Clutch

No.3

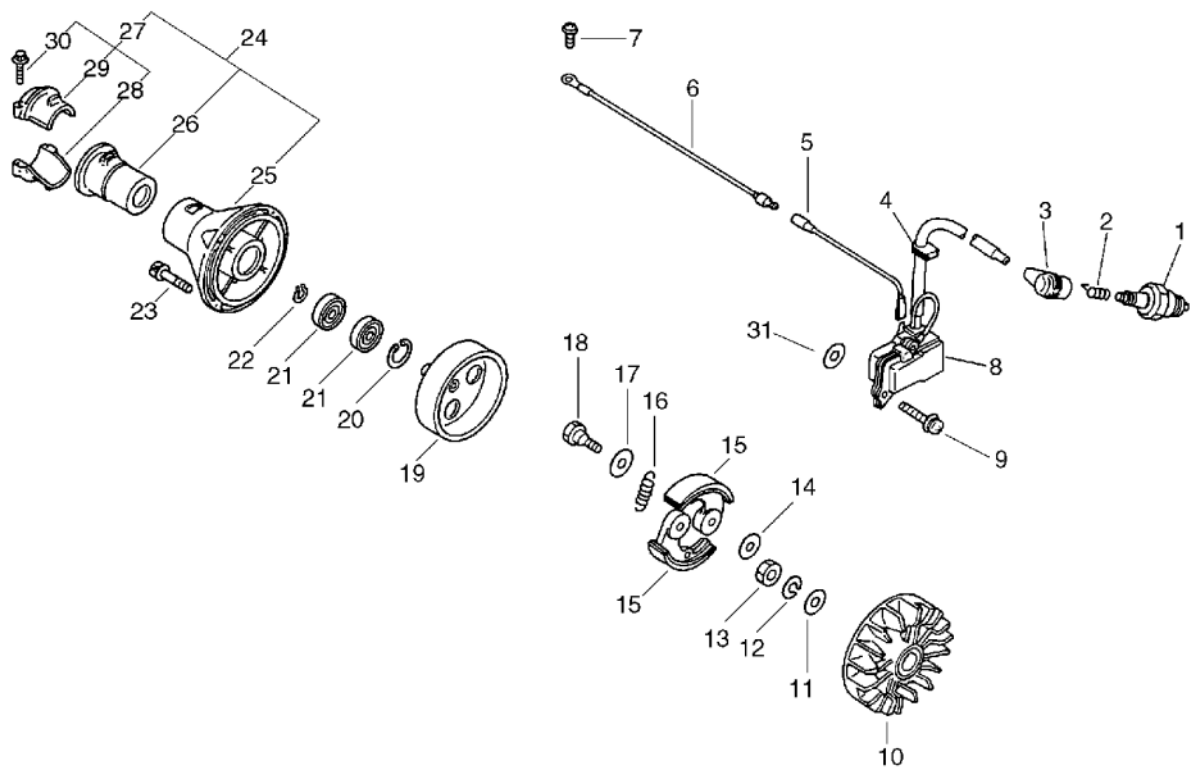

KEY	LV	PART NUMBER	Q'TY	DESCRIPTION	REMARKS	NOTE1	NOTE2
23		900162-05020	4	BOLT, H.S. 5*20	5*20 W,SW		
26		610910-40430	1	CUSHION		Sr/Nr 004950 and before	
27		610903-40430	1	HOLDER KIT		Sr/Nr 004950 and before	
30	+	900142-05025	2	BOLT 5*25 (W/W,SW)	5*25	Sr/Nr 004950 and before	
25		610205-43130	1	FLANGE (BS)		Sus. by 610203-43130	
24		610203-43130	1	FLANGE, ASY			
25	+	610205-43131	1	CASE, CLUTCH DRUM		Sr/Nr 004951 and after	
26	+	610910-55630	1	CUSHION		Sus. by 610910-51830	
26	+	610910-51830	1	CUSHION		Sr/Nr 004951 and after	
27	+	P021-000150	1	HOLDER KIT		Sr/Nr 004951 and after	
28	++	610922-55630	1	HOLDER, PIPE		Sr/Nr 004951 and after	
29	++	610922-43130	1	HOLDER, MAIN PIPE		Sr/Nr 004951 and after	
30	++	900162-05025	2	BOLT, H.S. 5*25	5*25 W,SW	Sr/Nr 004951 and after	
31		900600-00006	2	WASHER 6	6		

4. Air Cleaner

No.4

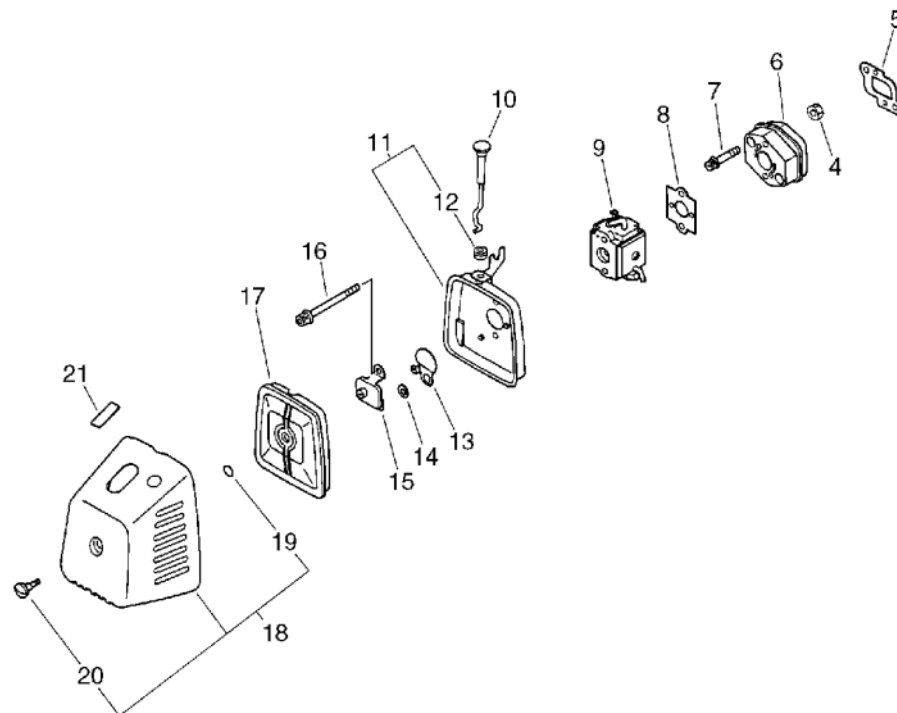

KEY	LV	PART NUMBER	Q'TY	DESCRIPTION	REMARKS	NOTE1	NOTE2
4		900500-00005	2	NUT 5	5		
5		130016-42231	1	GASKET, INTAKE			
6		130017-43130	1	INSULATOR			
7		900162-05025	2	BOLT, H.S. 5*25	5*25 W,SW		
8		130016-06232	1	GASKET, INTAKE			
9		123000-51430	1	CARBURETOR ASSY	WT-297		
10		178510-47530	1	ROD, CHOKE			
11		130301-43130	1	CASE, AIR CLEANER			
12	+	178810-05230	1	GROMMET			
13		178515-43130	1	SHUTTER, CHOKE			
14		178516-00830	2	SPACER	5.2*8*0.8T		
15		129006-43130	1	PLATE			
16		900242-05057	2	SCREW 5*57	5*57		
17		130310-43130	1	FILTER, AIR			
18		130302-43132	1	COVER ASSY, AIR CLN.			
19	+	900720-00004	1	O-RING (P-4)	P-4		
20	+	130415-40630	1	SCREW			
21		890121-47530	1	LABEL, CHOKE			

5. Muffler, Fuel Tank

No.5

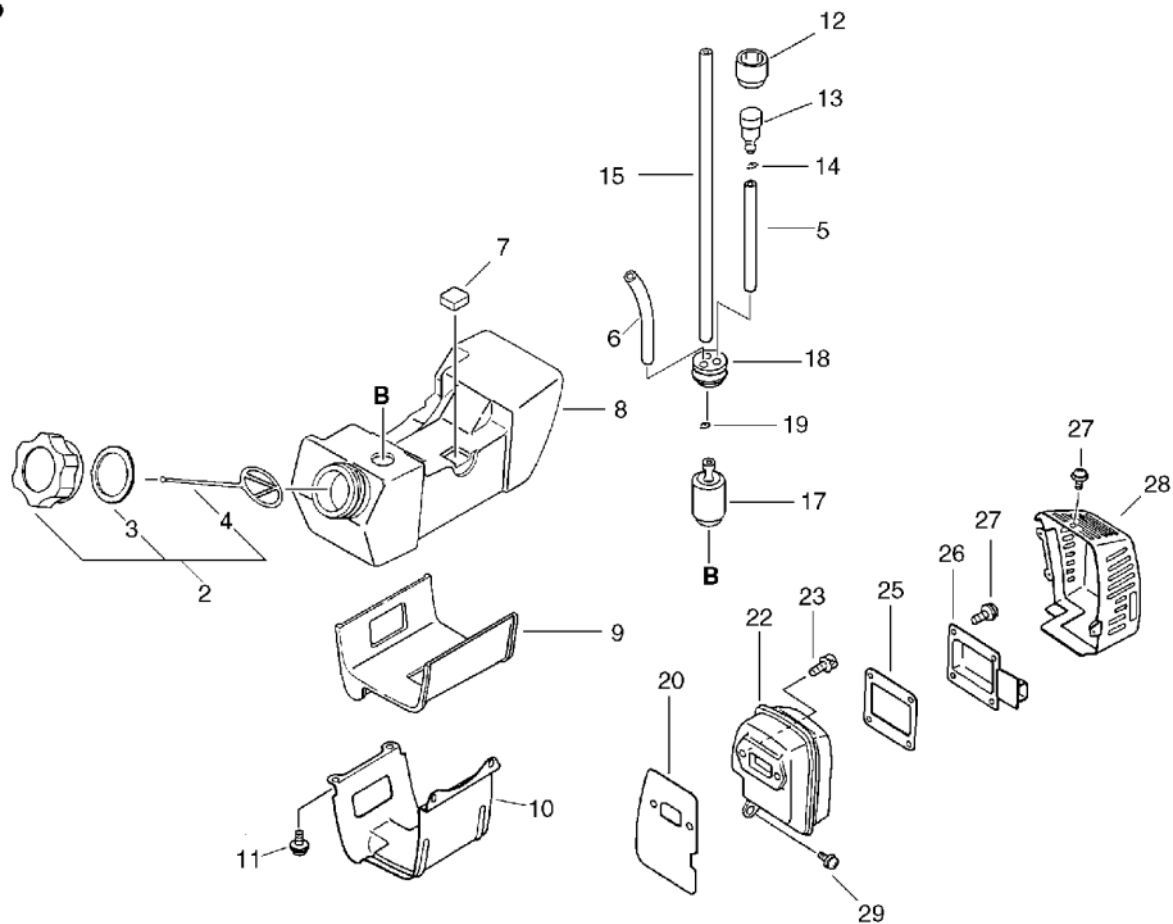

KEY	LV	PART NUMBER	Q'TY	DESCRIPTION	REMARKS	NOTE1	NOTE2
2		131004-55530	1	CAP ASSY, FUEL TANK			
3	+	131016-55830	1	GASKET, FUEL CAP			
4	+	131051-56030	1	CLIP, FUEL CAP	100L		
5		132010-51230	1	PIPE	3*5*60 NBR		
6		132010-56330	1	PIPE 3*6*90	3*6*90 YL		
7		131923-11120	3	CUSHION			
8		131010-46930	1	TANK, FUEL		Sus. by 131010-46931	
8		131010-46931	1	TANK, FUEL			
9		131924-43130	1	CUSHION			
10		131910-43130	1	BRACKET, FUEL TANK (BL)			
11		900238-05014	2	SCREW 5*14	5*14		
12		131328-40630	1	COVER, VENT			
13		131300-56430	1	VALVE, CHECK			
14		130111-00530	1	CLIP	5.5		
15		132010-13930	1	PIPE, FUEL	3*5*180L NBR	Sus. by V471-001190	
15		V471-001190	1	PIPE	3*5*180 NBR		
17		131205-19830	1	STRAINER, FUEL			
18		132115-46730	1	GROMMET, FUEL			
19		132013-09820	1	CLIP	6MM		
20		145510-42231	1	GASKET, MUFFLER			
22		145610-43130	1	MUFFLER (BL)			
23		900162-05020	2	BOLT, H.S. 5*20	5*20 W, SW		
25		145866-43131	1	GASKET, MUFFLER LID			

5. Muffler, Fuel Tank

No.5

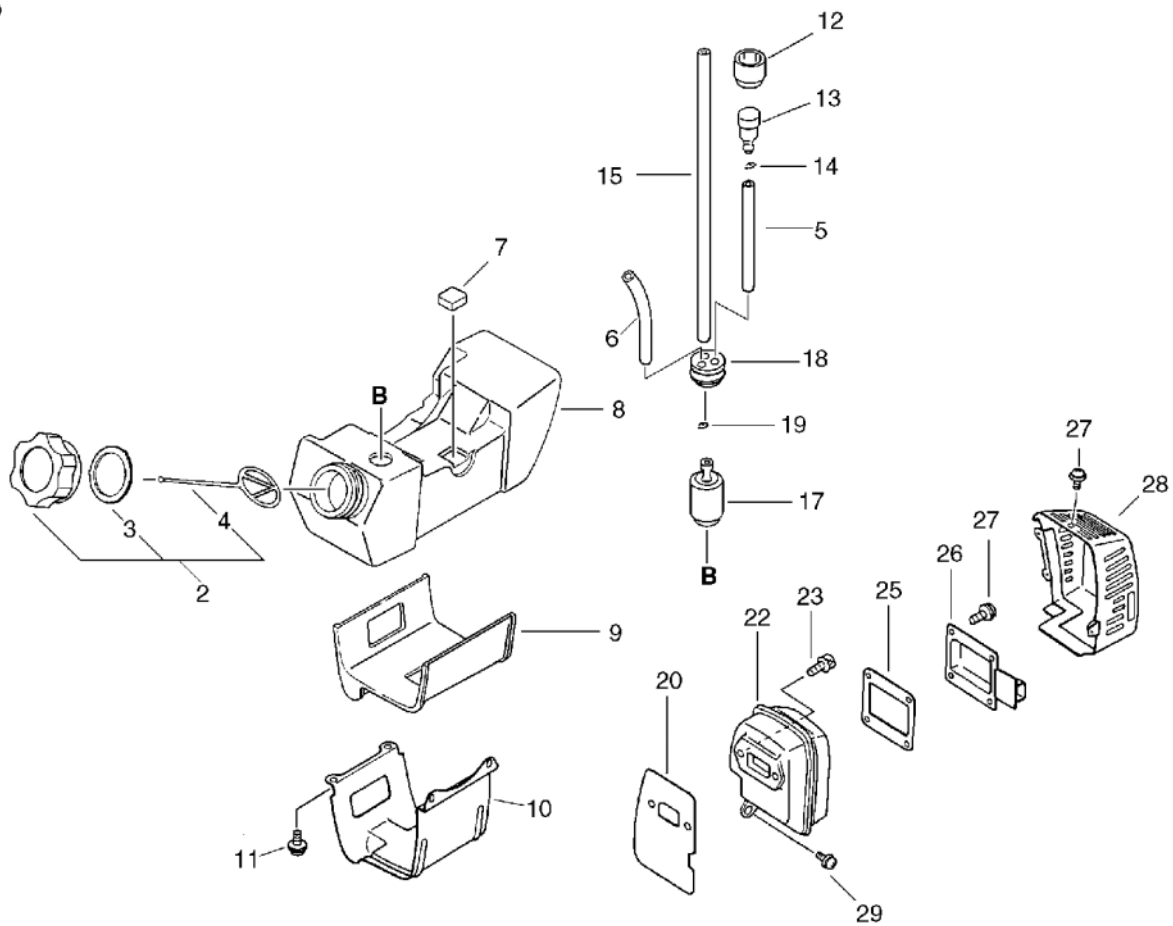

KEY	LV	PART NUMBER	Q'TY	DESCRIPTION	REMARKS	NOTE1	NOTE2
26		145867-43131	1	LID, MUFFLER			
27		900238-04010	7	SCREW 4*10	4*10		
28		145871-43130	1	COVER, MUFFLER			
29		900238-05014	1	SCREW 5*14	5*14		

6. Shield(Drive Shaft Sr/Nr 049468 and before)

No.6

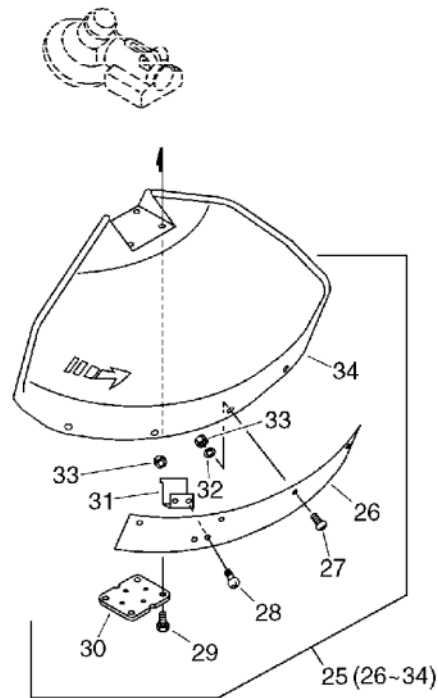

KEY	LV	PART NUMBER	Q'TY	DESCRIPTION	REMARKS	NOTE1	NOTE2
25		699000-52930	1	SHIELD ASSY		Sus. by 699000-52931	
25		699000-52931	1	SHIELD ASY		Drive Shaft Sr/Nr 049468 and before	
26	+	699013-52130	1	PLATE, SHIELD		Drive Shaft Sr/Nr 049468 and before	
27	+	900162-05018	4	BOLT, H.S. 5*18	5*18 W,SW	Drive Shaft Sr/Nr 049468 and before	
28	+	900162-05014	2	BOLT, H.S. 5*14	5*14 W,SW	Drive Shaft Sr/Nr 049468 and before	
29	+	900162-05025	4	BOLT, H.S. 5*25	5*25 W,SW		
30	+	699013-56830	1	PLATE, SHIELD			
31	+	699016-52130	1	KNIFE, CORD		Sus. by 699016-54530	
31	+	699016-54530	1	KNIFE		Drive Shaft Sr/Nr 049468 and before	
32	+	900603-00005	4	WASHER 5	5.5*12*0.8	Drive Shaft Sr/Nr 049468 and before	

6. Shield(Drive Shaft Sr/Nr 049468 and before)

No.6

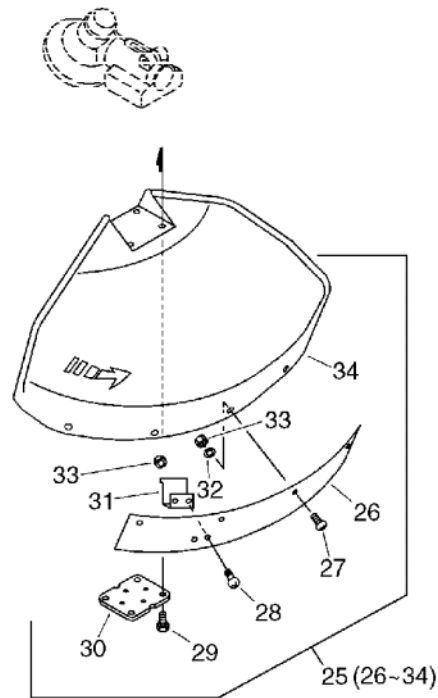

KEY	LV	PART NUMBER	Q'TY	DESCRIPTION	REMARKS	NOTE1	NOTE2
33	+	900500-00005	6	NUT 5	5	Drive Shaft Sr/Nr 049468 and before	
34	+	699010-52930	1	SHIELD, BLADE		Sus. by 699010- 52931	
34	+	699010-52931	1	SHIELD, BLADE		Drive Shaft Sr/Nr 049468 and before	

7. Shield(Drive Shaft Sr/Nr 049469 and after), Tools

No.7

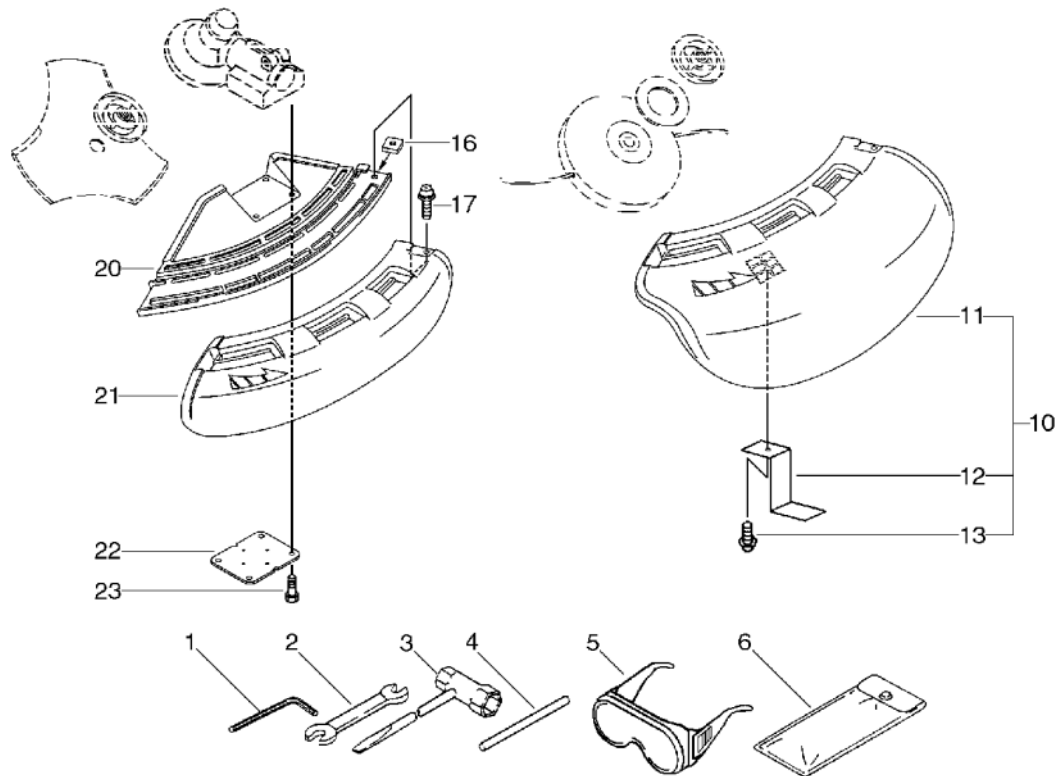

KEY	LV	PART NUMBER	Q'TY	DESCRIPTION	REMARKS	NOTE1	NOTE2
1		895610-00130	1	L-WRENCH (4MM)			
2		895112-00330	1	SPANNER 8*10			
3		895410-08030	1	WRENCH, W/S. DRIVER		Sus. by X602-000020	
3		X602-000020	1	TOOL,WRENCH	17*19 L200		
4		897518-01131	1	LOCKING TOOL			
5		899580-40930	1	GOGGLE		Sus. by P021-002861	
5		899580-68730	1	SAFETY GLASSES		Sus. by P021-002861	
5		P021-002861	1	GOGGLES			
6		898510-39130	1	BAG, TOOL			
10		P021-002620	1	SHIELD,BLADE(W/KNIFE		Drive Shaft Sr/Nr 049469 and after	
11	+	C550-000080	1	SHIELD,BLADE		Drive Shaft Sr/Nr 049469 and after	
12	+	C554-000000	1	KNIFE,CORD		Drive Shaft Sr/Nr 049469 and after	
13	+	900252-05012	1	SCREW 5*12	5*12	Drive Shaft Sr/Nr 049469 and after	

7. Shield(Drive Shaft Sr/Nr 049469 and after), Tools

No.7

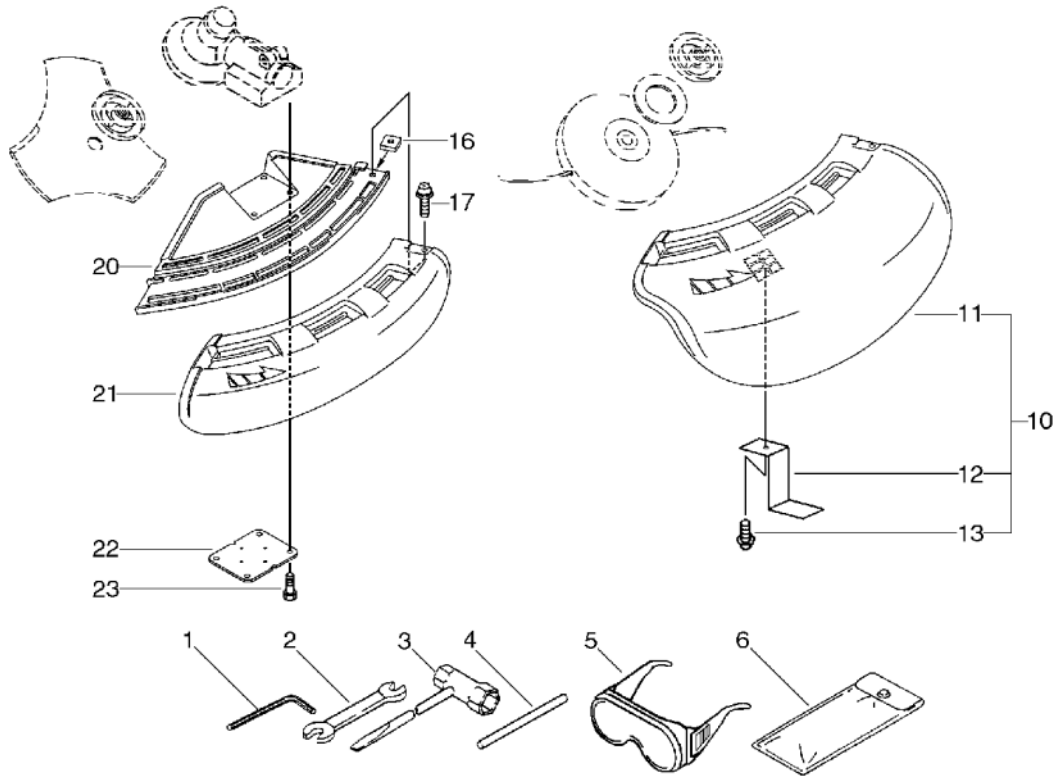

KEY	LV	PART NUMBER	Q'TY	DESCRIPTION	REMARKS	NOTE1	NOTE2
16		900565-00005	1	NUT	5	Drive Shaft Sr/Nr 049469 and after	
17		900242-05018	1	SCREW 5*18	5*18	Drive Shaft Sr/Nr 049469 and after	
20		C550-000100	1	SHIELD, BLADE		Drive Shaft Sr/Nr 049469 and after	
21		C550-000090	1	SHIELD, BLADE		Drive Shaft Sr/Nr 049469 and after	
22		699013-56830	1	PLATE, SHIELD			
23		900162-05025	4	BOLT, H.S. 5*25	5*25 W, SW		

8. U-Handle

No.8

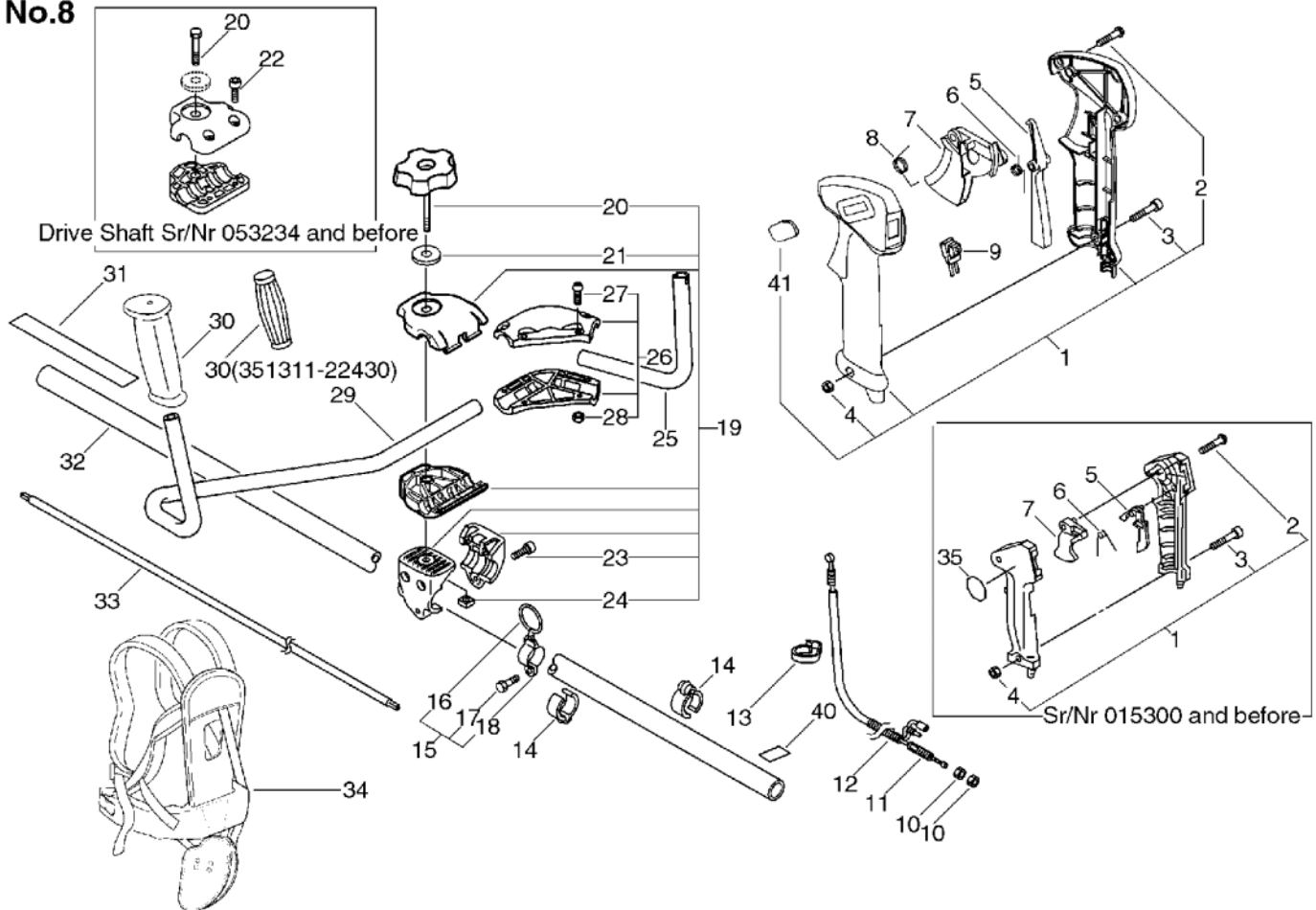

KEY	LV	PART NUMBER	Q'TY	DESCRIPTION	REMARKS	NOTE1	NOTE2
1		351102-47530	1	GRIP ASSY, F-HANDLE		Sr/Nr 015300 and before	
1		P021-002610	1	GRIP ASY,F-HANDLE		Sus. by P021-002612	
1		P021-002611	1	GRIP ASY,F-HANDLE		Sus. by P021-002612	
1		P021-002612	1	GRIP ASY,F-HANDLE		Sr/Nr 015301 and after	
2	+	900246-03025	4	SCREW 3*25	3*25	Sr/Nr 015300 and before	
2	+	900246-04016	3	SCREW 4*16	4*16	Sus. by 900253-04016	
2	+	900253-04016	3	SCREW 4*16	4*16	Sr/Nr 015301 and after	
3	+	900220-05030	1	SCREW 5*30	5*30		
4	+	900500-00005	1	NUT 5	5		
41	+	V162-000130	1	PLUG		Can be used on P021-002611 only	
5		178012-05960	1	LOCKOUT, THROTTLE		Sr/Nr 015300 and before	
5		C460-000010	1	LOCKOUT,THROTTLE		Sus. by C460-000011	
5		C460-000011	1	LOCKOUT,THROTTLE		Sr/Nr 015301 and after	

8. U-Handle

No.8

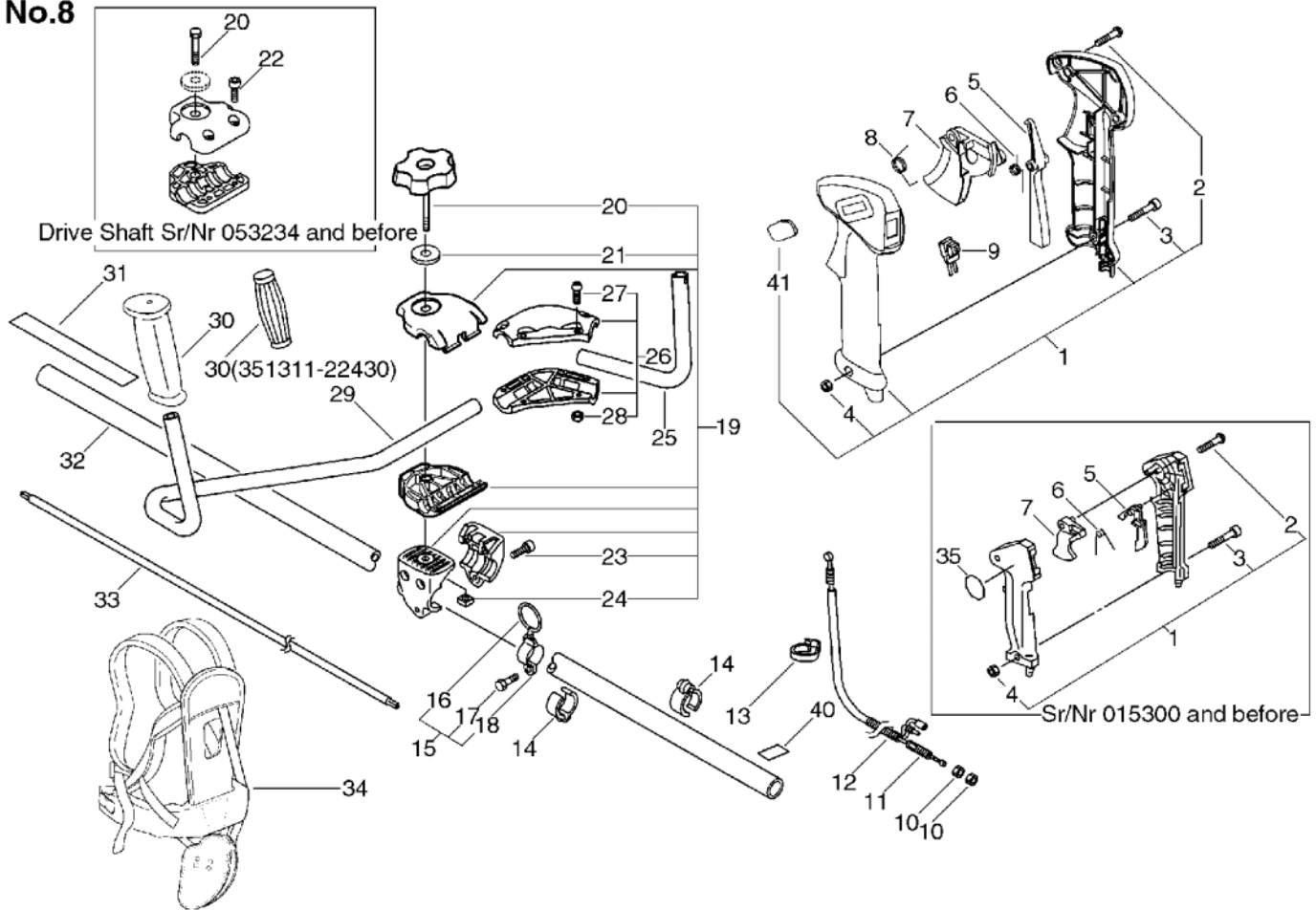

KEY	LV	PART NUMBER	Q'TY	DESCRIPTION	REMARKS	NOTE1	NOTE2
6		178013-35631	1	SPRING, THR. LOCK		Sr/Nr 015300 and before	
6		V452-000050	1	SPRING, TORSION		Sr/Nr 015301 and after	
7		178010-05960	1	CONTROL, THROTTLE		Sr/Nr 015300 and before	
7		C450-000020	1	TRIGGER, THROTTLE		Sus. by C450-000021	
7		C450-000021	1	TRIGGER, THROTTLE		Sr/Nr 015301 and after	
8		V452-000060	1	SPRING, TORSION		Sr/Nr 015301 and after	
9		163401-43130	1	SWITCH, IGNITION			
10		900502-00006	2	NUT 6 (3N)	3N6		
11		178001-43230	1	WIRE, THROTTLE		Sr/Nr 015300 and before	
11		V430-000400	1	CABLE, BOWDEN		Sr/Nr 015301 and after	
12		178127-43230	1	TUBE	7*820		
13		159112-09960	1	CLIP		Sus. by 159112-09961	
13		159112-09961	1	CLIP			
14		224924-52930	2	CLIP	28MM		
15		301200-05230	1	HOOK ASS'Y			
16	+	301015-05330	1	HOOK, BAND			
17	+	900105-05012	1	BOLT, H.S. 5*12	5*12		

8. U-Handle

No.8

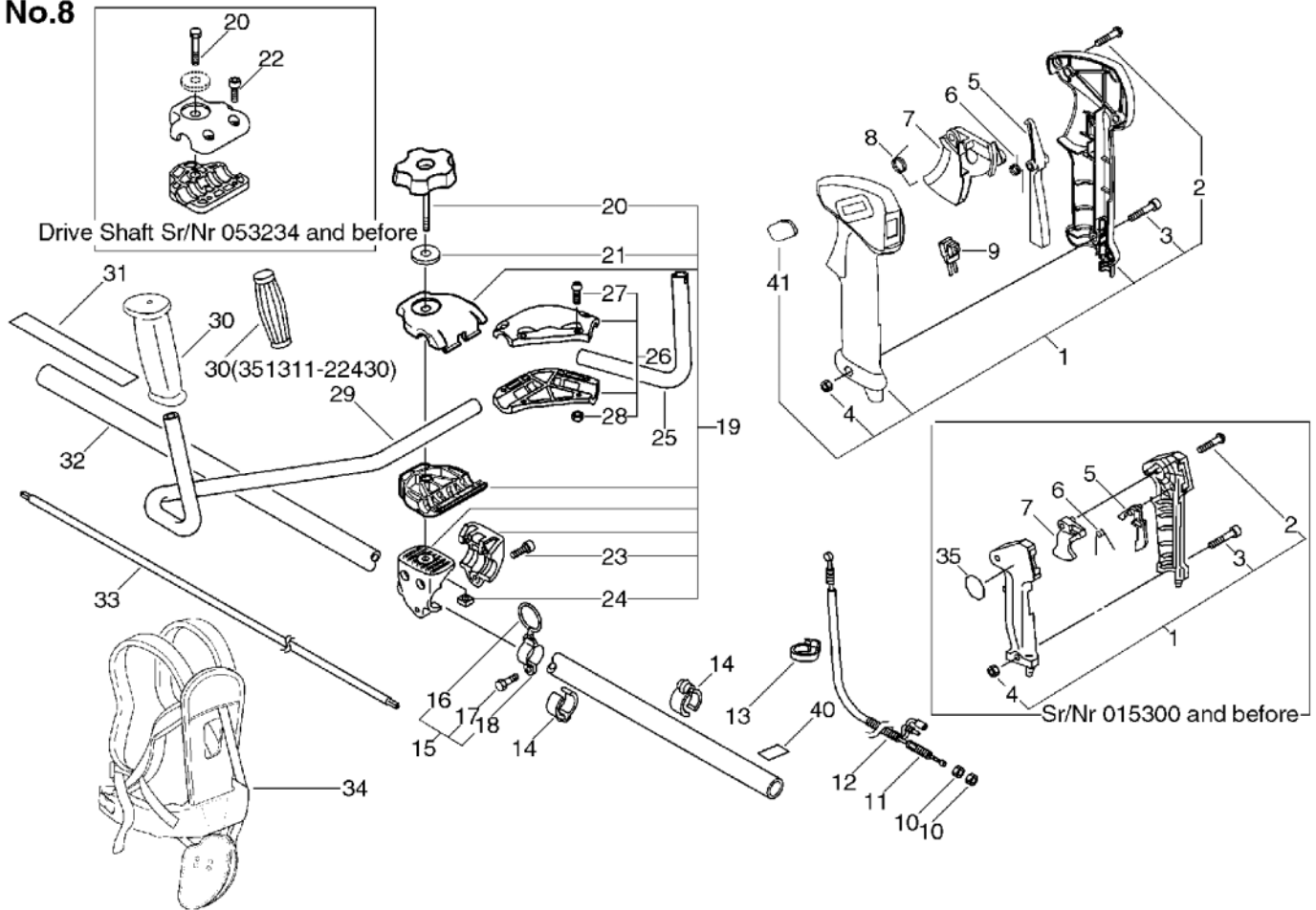

KEY	LV	PART NUMBER	Q'TY	DESCRIPTION	REMARKS	NOTE1	NOTE2
18	+	301210-04630	1	HOOK			
19		351301-52930	1	BRACKET ASSY, HANDLE		Drive Shaft Sr/Nr 053234 and before	
19		P021-002760	1	BRACKET ASY, HANDLE		Sus. by P021-002761	
19		P021-002761	1	BRACKET ASY, HANDLE		Drive Shaft Sr/Nr 053235 and after	
20	+	351421-52130	1	BOLT		Drive Shaft Sr/Nr 053234 and before	
20	+	V299-000110	1	KNOB,FASTENER		Drive Shaft Sr/Nr 053235 and after	
21	+	605014-54230	1	WASHER			
22	+	900162-05020	2	BOLT, H.S. 5*20	5*20 W,SW	Drive Shaft Sr/Nr 053234 and before	
23	+	900162-05030	3	BOLT, H.S. 5*30	5*30 W,SW		
24	+	900565-50008	1	NUT	8*1.25		
25		351214-52930	1	HANDLE		Sus. by 351214-52931	
25		351214-52931	1	HANDLE			
26		351202-51430	1	BRACKET ASSY, HANDLE			
27	+	900162-05020	4	BOLT, H.S. 5*20	5*20 W,SW		

8. U-Handle

No.8

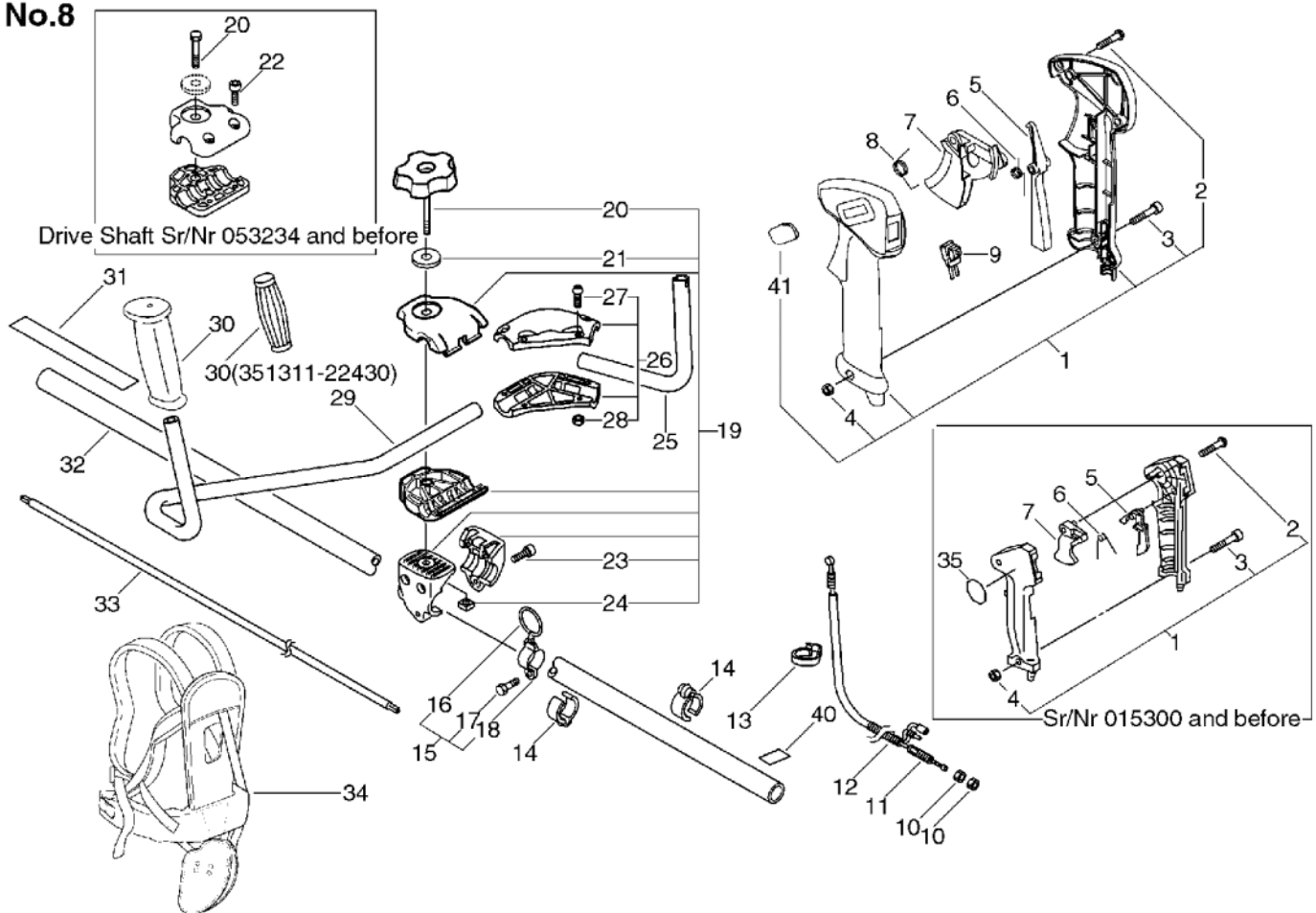

KEY	LV	PART NUMBER	Q'TY	DESCRIPTION	REMARKS	NOTE1	NOTE2
28	+	900500-00005	4	NUT 5	5		
29		351010-52930	1	HANDLE, FRONT		Sus. by 351210-52931	
29		351010-52931	1	HANDLE, FRONT			
30		351311-22430	1	GRIP, HANDLE		Drive Shaft Sr/Nr 049468 and before	
30		C403-000030	1	GRIP,HANDLE		Sus. by C403-000031	
30		C403-000031	1	GRIP,HANDLE		Drive Shaft Sr/Nr 049469 and after	
31		890617-46830	1	LABEL, CAUTION		Sus. by 890617-43130	
31		890617-43130	1	LABEL,CAUTION			
32		610206-43130	1	HOUSING ASSY, D.SHFT			
33		610011-06230	1	SHAFT, DRIVE			
34		301001-56830	1	HARNESS, SHOULDER		Sus. by C062-000181	
34		301001-56831	1	HARNESS ASY,SHOULDER		Sus. by C062-000181	
34		C062-000180	1	HARNESS,SHOULDER	ECHO	Sus. by C062-000181	
34		C062-000181	1	HARNESS,SHOULDER			
35		890157-39130	1	LABEL, SWITCH		Sr/Nr 015300 and before	

8. U-Handle

No.8

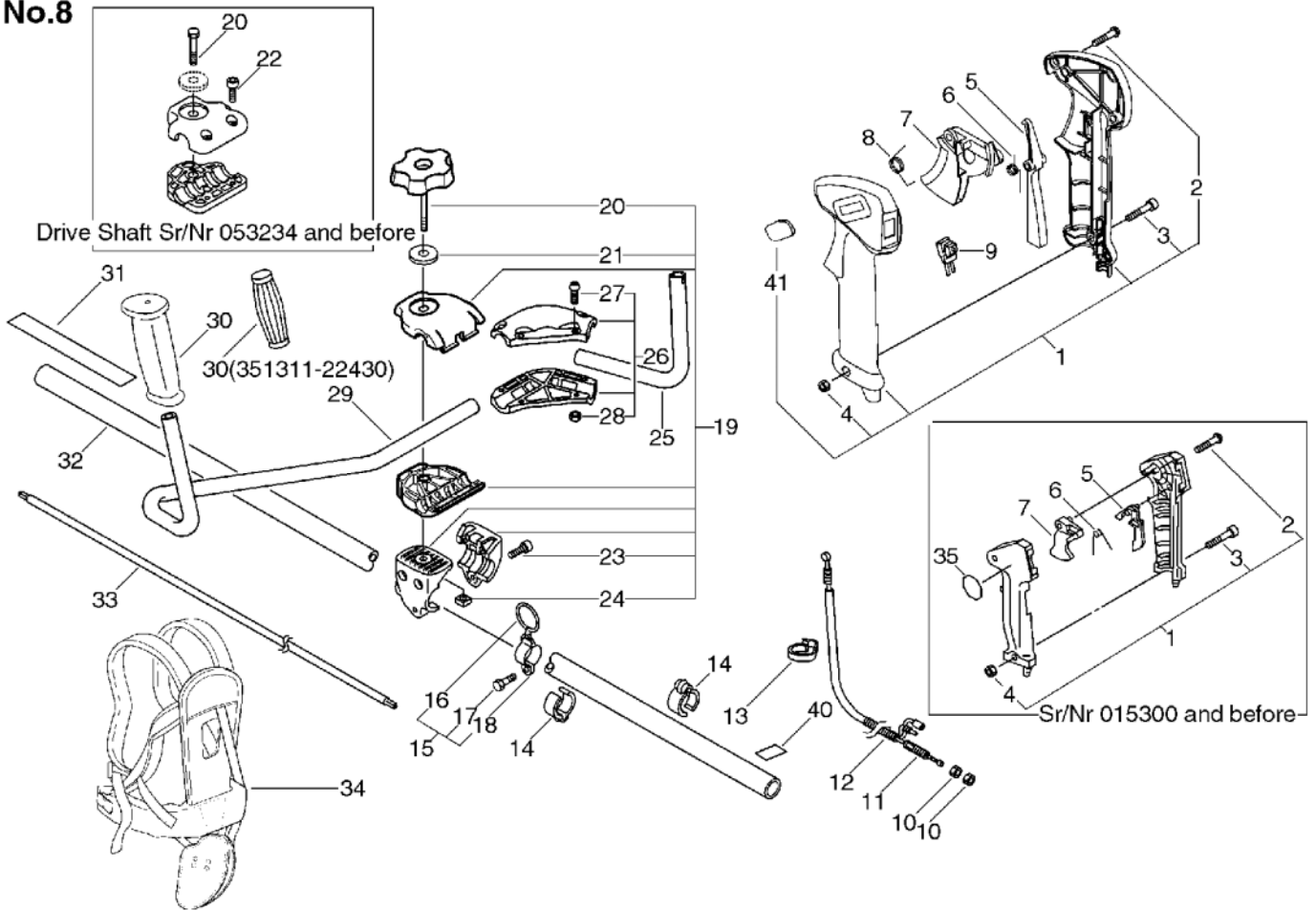

KEY	LV	PART NUMBER	Q'TY	DESCRIPTION	REMARKS	NOTE1	NOTE2
40		890152-04930	1	LABEL, CAUTION			

9. Gear Case(U-Handle Type), Blade No.9

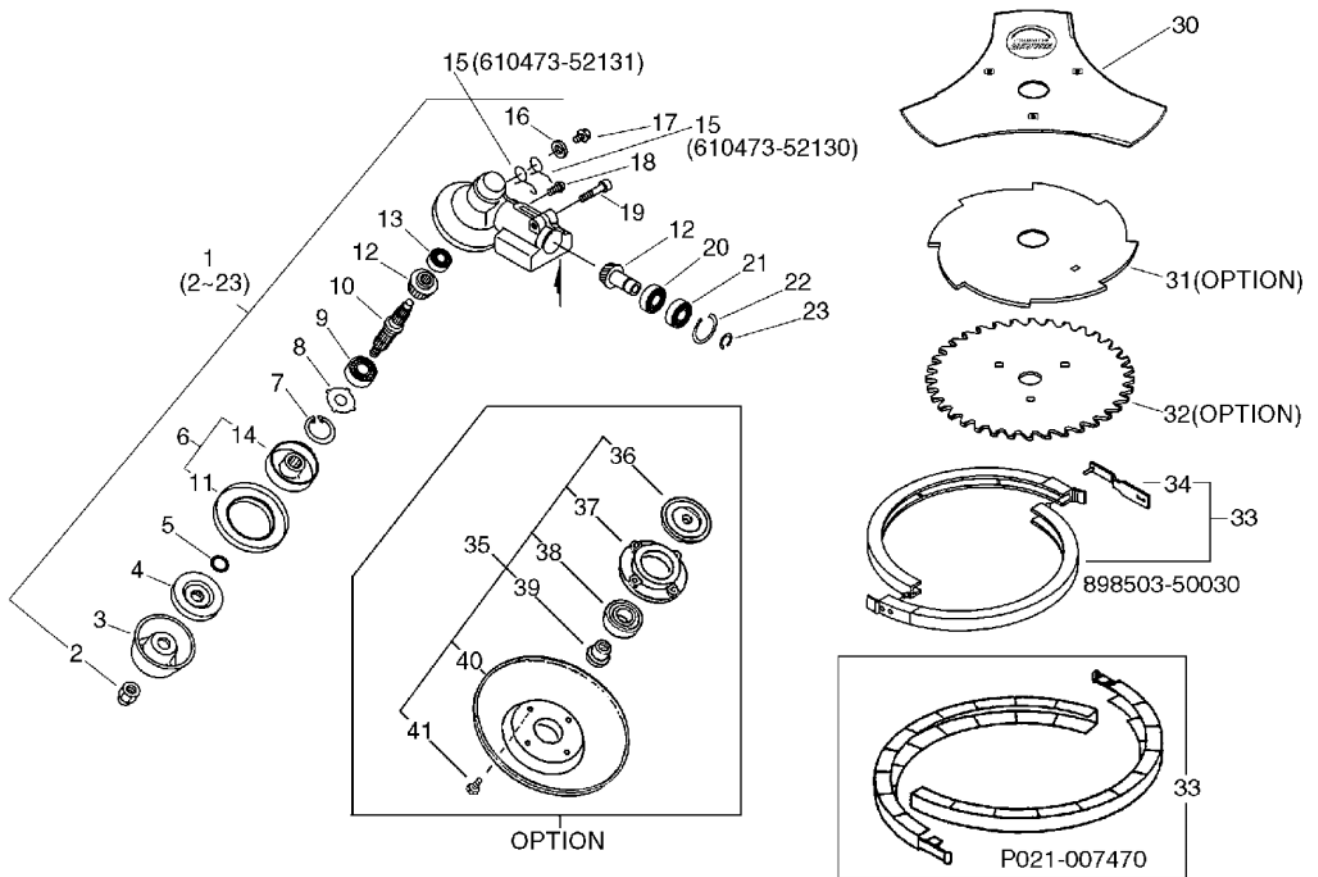

KEY	LV	PART NUMBER	Q'TY	DESCRIPTION	REMARKS	NOTE1	NOTE2
1		610400-56930	1	HOUSING ASSY, GEAR		Sus. by 610400-56932	
1		610400-56931	1	CASE ASY, GEAR		Sus. by 610400-56932	
1		610400-56932	1	CASE ASY, GEAR			
2	+	610320-52130	1	NUT 10			
3	+	699229-56830	1	PLATE, COVER			
4	+	610314-52130	1	PLATE, ADAPTER (L)			
5	+	900720-00012	1	O-RING 12	P-12		
6	+	610313-52930	1	PLATE, ADAPTER (U)		Sus. by C535-000001	
6	+	C535-000000	1	FIXTURE, BLADE		Sus. by C535-000001	
6	+	C535-000001	1	FIXTURE, BLADE			
11	++	610352-56830	1	PLATE, CUP			
14	++	C535-000010	1	FIXTURE, BLADE		Sus. by C535-000011	
14	++	C535-000011	1	FIXTURE, BLADE			
7	+	900702-00032	1	CIRCLIP 32	CR-32		
8	+	610444-56830	1	WASHER			
9	+	900812-06201	1	BEARING, BALL 6201	6201DDU(LLU)		
10	+	610310-56930	1	SHAFT, P.T.O.			
12	+	610300-56930	1	GEAR SET			
13	+	900810-00629	1	BEARING, BALL 629	629		

9. Gear Case(U-Handle Type), Blade No.9

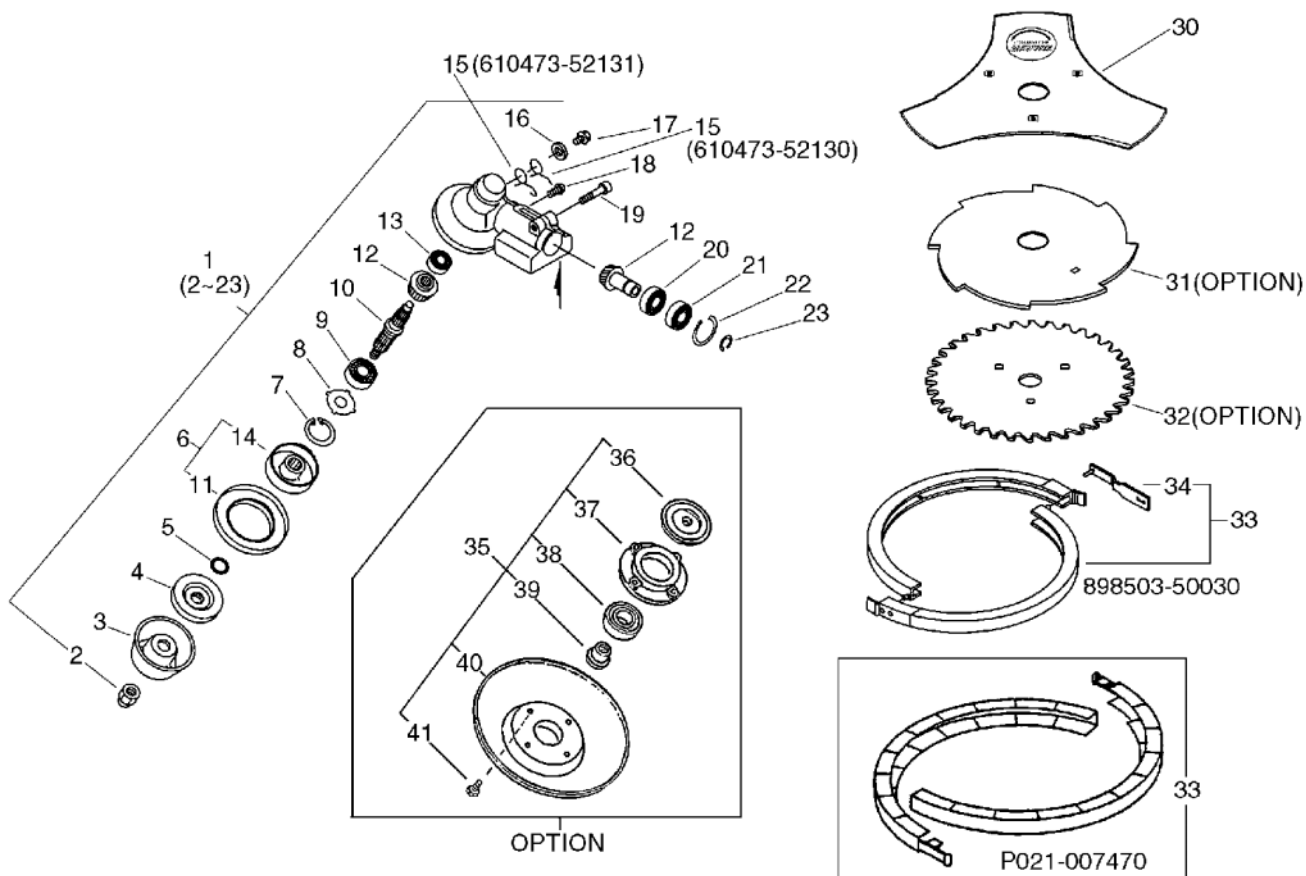

KEY	LV	PART NUMBER	Q'TY	DESCRIPTION	REMARKS	NOTE1	NOTE2
15	+	610473-52130	1	SPRING, TORSION		Drive Shaft Sr/Nr 024886 and before	
15	+	610473-52131	1	SPRING		Drive Shaft Sr/Nr 024887 and after	
16	+	900603-50008	1	WASHER	8.5*18*0.8T		
17	+	610434-50030	1	BOLT 8* 6		Sus. by 610434- 50031	
17	+	610434-50031	1	BOLT 8* 8	M8*8		
18	+	900242-05010	1	SCREW 5*10	5*10		
19	+	900162-06030	1	BOLT, H.S. 6*30	6*30W、SW		
20	+	900800-06001	1	BEARING, BALL 6001	6001		
21	+	900807-06001	1	BEARING, BALL 6001	6001V(LB)	Drive Shaft Sr/Nr 024886 and before	
21	+	900803-06001	1	BEARING, BALL 6001	6001Z	Drive Shaft Sr/Nr 024887 and after	
22	+	900702-00028	1	CIRCLIP 28	CR-28		
23	+	900701-00012	1	CIRCLIP 12	CS-12		
30		X405-000000	1	SAW,BUSH CUTTER	3*255*25.4*T2.0	Sus. by X405- 000001	
30		X405-000001	1	SAW,BUSH CUTTER	3*255*25.4*T2.0		

9. Gear Case(U-Handle Type), Blade No.9

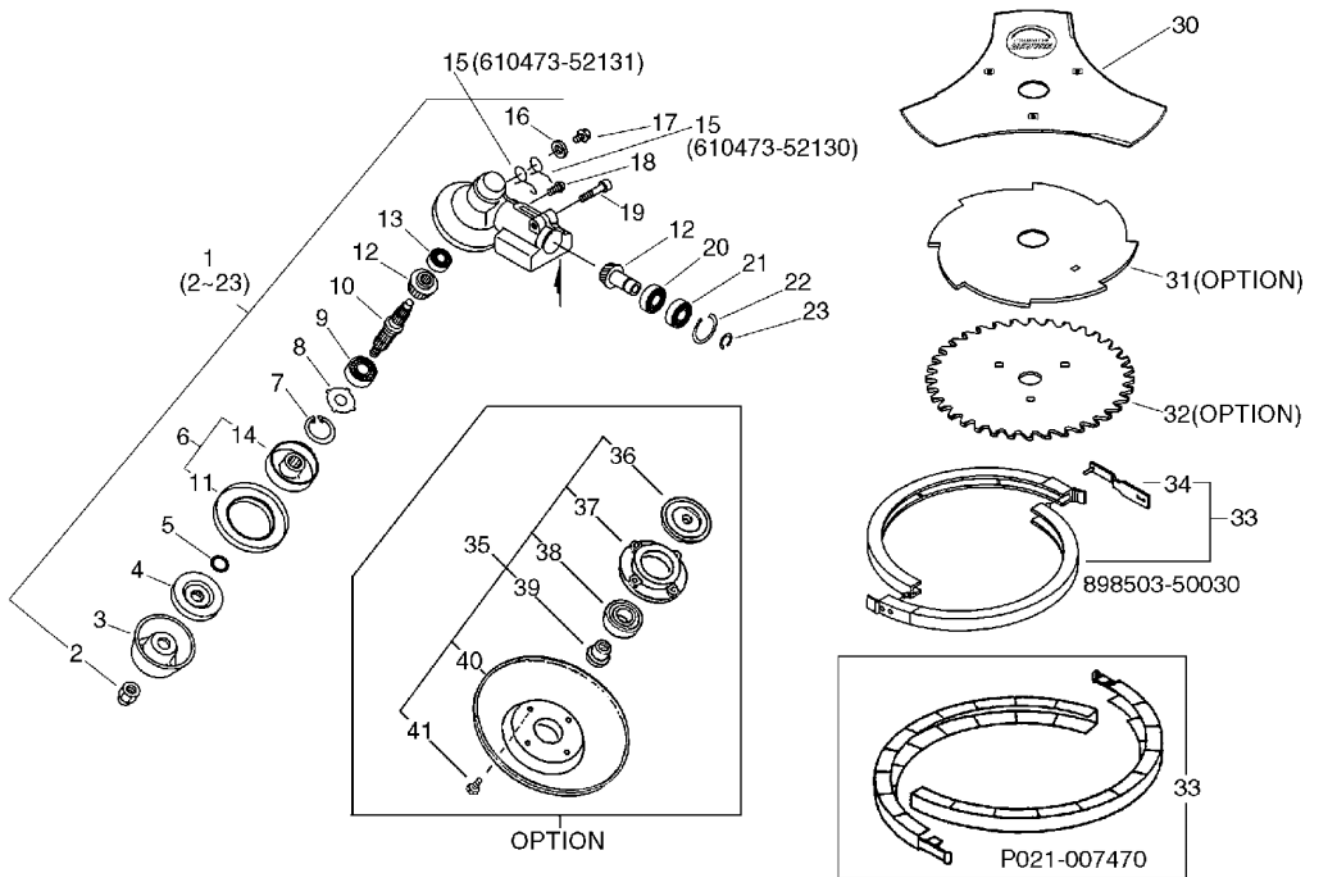

KEY	LV	PART NUMBER	Q'TY	DESCRIPTION	REMARKS	NOTE1	NOTE2
33		898503-50030	1	SCABBARD KIT, BLADE		Sus. by P021-007470	
33		P021-007470	1	SCABBARD, BLADE			
34	+	898562-43230	1	FIXTURE, SCABBARD		Can be used on 898503-50030 only	
31		696001-55631	1	BLADE, 8-CUTTER 10IN	255*8T*1.4 PD25	OPTION	
32		695001-55631	1	SAW, CIRCULAR 10*80T	255*80T*1.4 PD25	OPTION	
35		699200-56830	1	CAP ASSY, FREE		OPTION	
36	+	610313-56830	1	PLATE, ADAPTER (U)		OPTION	
37	+	699226-05430	1	HOLDER, BEARING		OPTION	
38	+	900814-06202	1	BEARING, BALL 6202	6202ZZ	OPTION	
39	+	699227-04630	1	NUT		OPTION	
40	+	699228-08930	1	PLATE, COVER		OPTION	
41	+	900141-05012	4	BOLT 5*12	5*12	OPTION	

10. Loop Handle

No.10

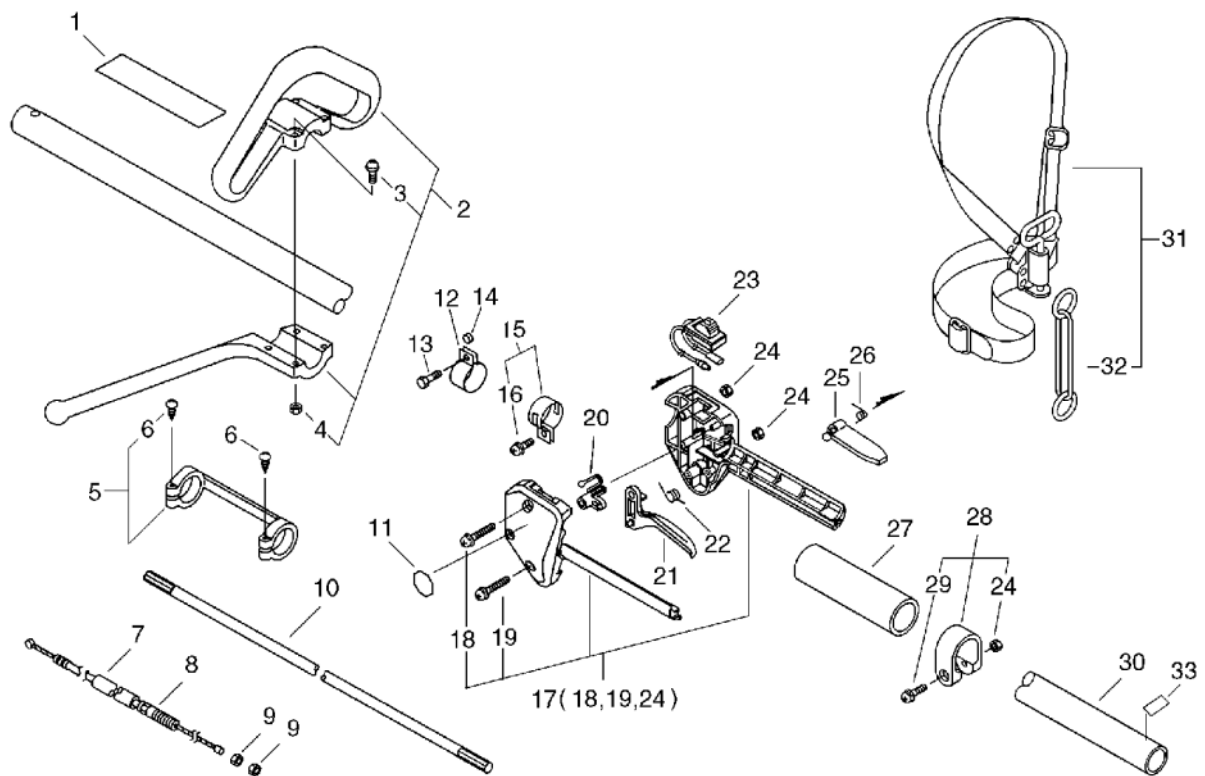

KEY	LV	PART NUMBER	Q'TY	DESCRIPTION	REMARKS	NOTE1	NOTE2
1		890177-46730	1	LABEL, CAUTION			Sus. by 890617-43130
1		890617-63630	1	LABEL, CAUTION			Sus. by 890617-43130
1		X505-000140	1	LABEL, CAUTION			Sus. by 890617-43130
1		890617-43130	1	LABEL, CAUTION			
2		351201-55630	1	HANDLE ASSY, LOOP			
3	+	900242-05035	4	SCREW 5*35	5*35		
4	+	900500-00005	4	NUT 5	5		
5		610281-42230	1	COLLER			
6	+	900253-04025	2	SCREW 4*25	4*25		
7		178001-12620	1	WIRE, THROTTLE			
8		178127-43130	1	TUBE	7*230		
9		900502-00006	2	NUT 6 (3N)	3N6		
10		610011-06230	1	SHAFT, DRIVE			
11		890157-39130	1	LABEL, SWITCH			
12		301207-07530	1	HOOK			
13		900100-05018	1	BOLT 5*18	5*18		
14		699012-03330	1	SPACER			
15		301200-42230	1	HOOK ASSY			
16	+	900242-05014	1	SCREW 5*14	5*14		
17		178003-51830	1	BRACKET SET, THROTTLE			
18	+	900242-05035	1	SCREW 5*35	5*35		
19	+	900242-05025	1	SCREW 5*25	5*25		
24	+	900500-00005	2	NUT 5	5		

10. Loop Handle

No.10

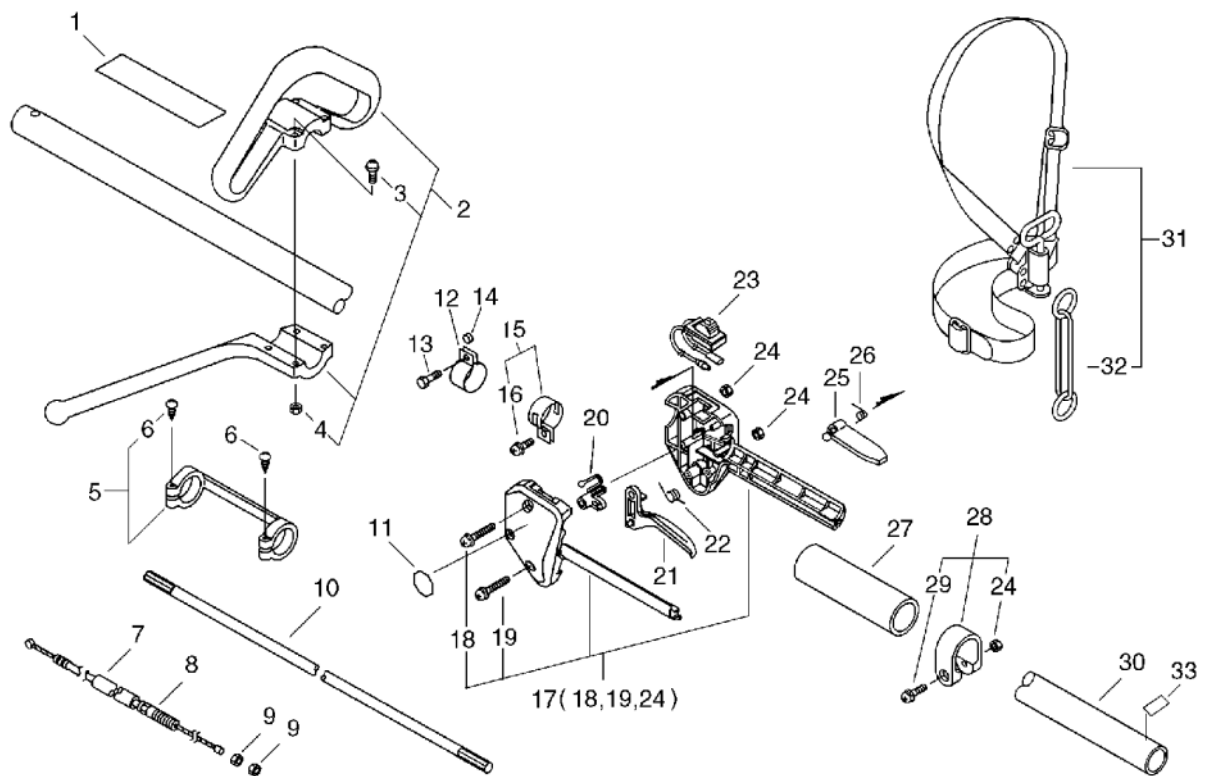

KEY	LV	PART NUMBER	Q'TY	DESCRIPTION	REMARKS	NOTE1	NOTE2
20		178012-52630	1	LOCKOUT, THROTTLE			
21		178010-52130	1	CONTROL, THROTTLE			
22		178043-42230	1	SPRING, THR. RETURN			
23		163400-49330	1	SWITCH, IGNITION			
25		178090-52630	1	LOCKOUT, T. CONTROL		Sus. by 178090-52632	
25		178090-52631	1	LOCKOUT, T. CONTROL		Sus. by 178090-52632	
25		178090-52632	1	LOCKOUT, T. CONTROL			
26		178013-52630	1	SPRING, THR. LOCK			
27		351213-51830	1	GRIP, FRONT HANDLE			
28		610272-51830	1	BAND			
24	+	900500-00005	1	NUT 5	5		
29	+	900242-05028	1	SCREW 5*28	5*28		
30		610206-43130	1	HOUSING ASSY, D.SHFT			
31		301000-55230	1	HARNESS ASSY		Sus. by 301000-55231	
31		301000-55231	1	HARNESS ASY, SHOULDER			
32	+	301305-24330	1	LINK			
33		890152-04930	1	LABEL, CAUTION			

11. Gear Case(Loop Handle Type), Nylon Line Cutting Head

No.11

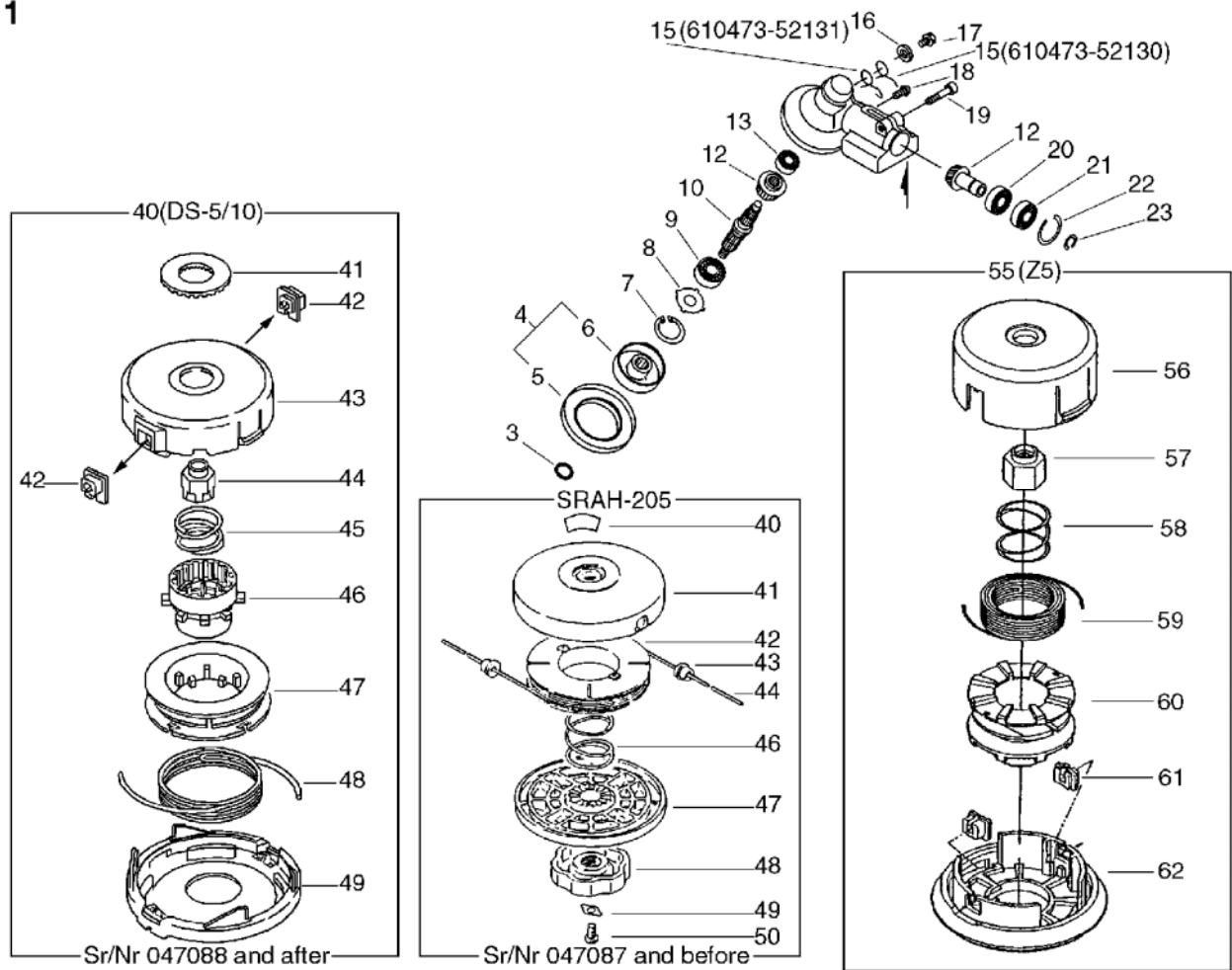

KEY	LV	PART NUMBER	Q'TY	DESCRIPTION	REMARKS	NOTE1	NOTE2
3		900720-00012	1	O-RING 12	P-12		
4		610313-52930	1	PLATE, ADAPTER (U)		Sus. by C535-000001	
4		C535-000000	1	FIXTURE, BLADE		Sus. by C535-000001	
4		C535-000001	1	FIXTURE, BLADE			
5	+	610352-56830	1	PLATE, CUP			
6	+	C535-000010	1	FIXTURE, BLADE		Sus. by C535-000011	
6	+	C535-000011	1	FIXTURE, BLADE			
7		900702-00032	1	CIRCLIP 32	CR-32		
8		610444-56830	1	WASHER			
9		900812-06201	1	BEARING, BALL 6201	6201DDU(LLU)		
10		610310-56930	1	SHAFT, P.T.O.			
12		610300-56930	1	GEAR SET			
13		900810-00629	1	BEARING, BALL 629	629		
15		610473-52130	1	SPRING, TORSION		Drive Shaft Sr/Nr 024886 and before	
15		610473-52131	1	SPRING		Drive Shaft Sr/Nr 024887 and after	
16		900603-50008	1	WASHER	8.5*18*0.8T		
17		610434-50030	1	BOLT 8*6		Sus. by 610434-50031	
17		610434-50031	1	BOLT 8*8	M8*8		

11. Gear Case(Loop Handle Type), Nylon Line Cutting Head

No.11

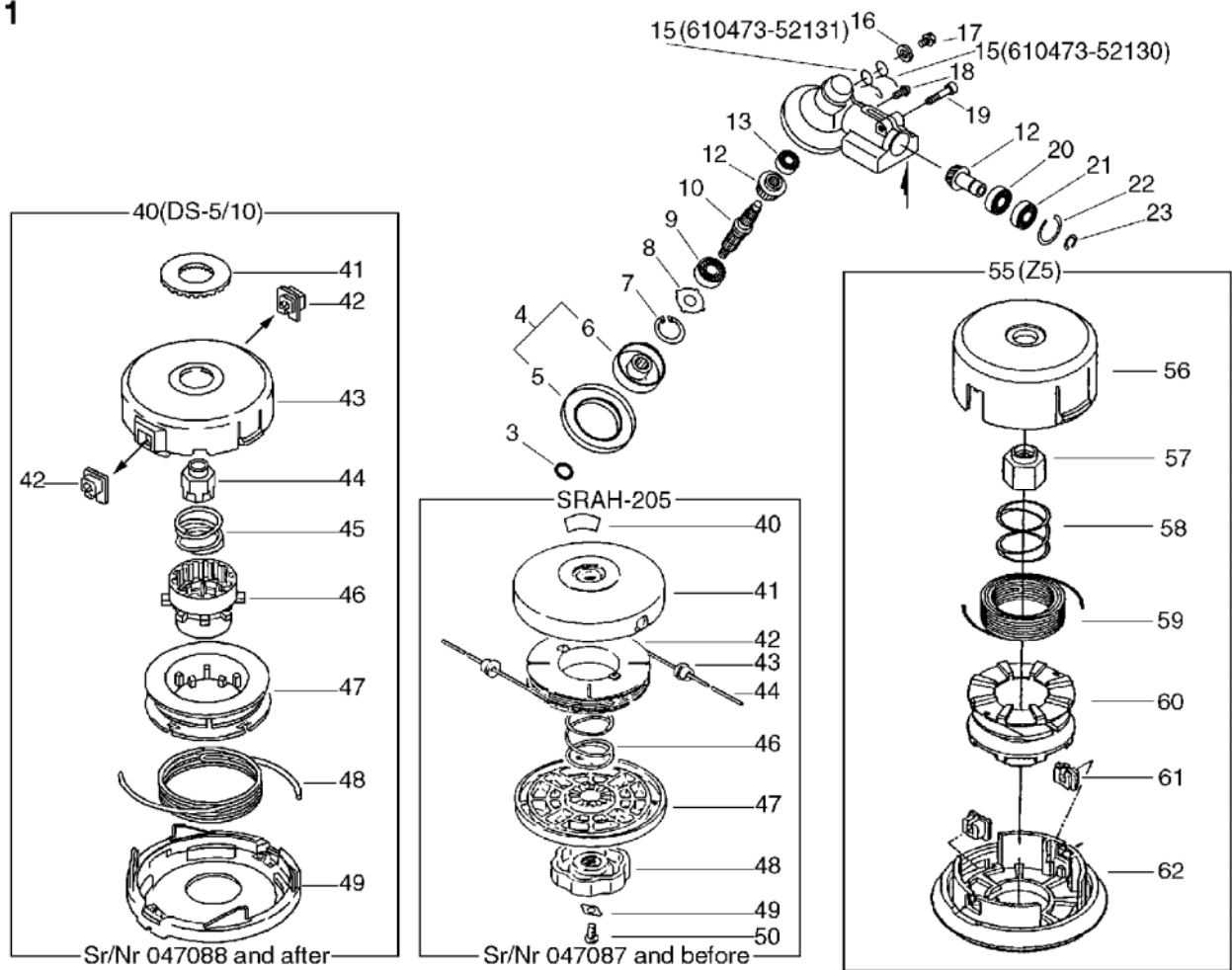

KEY	LV	PART NUMBER	Q'TY	DESCRIPTION	REMARKS	NOTE1	NOTE2
18		900242-05010	1	SCREW 5*10	5*10		
19		900162-06030	1	BOLT, H.S. 6*30	6*30W, SW		
20		900800-06001	1	BEARING, BALL 6001	6001		
21		900807-06001	1	BEARING, BALL 6001	6001V(LB)	Drive Shaft Sr/Nr 024886 and before	
21		900803-06001	1	BEARING, BALL 6001	6001Z	Drive Shaft Sr/Nr 024887 and after	
22		900702-00028	1	CIRCLIP 28	CR-28		
23		900701-00012	1	CIRCLIP 12	CS-12		
40		890617-46730	1	LABEL, CAUTION		Drive Shaft Sr/Nr 047087 and before	
41		696210-56930	1	DRUM, REEL		Drive Shaft Sr/Nr 047087 and before	
42		696214-06830	1	REEL, CORD		Drive Shaft Sr/Nr 047087 and before	
43		696212-06032	2	EYELET		Drive Shaft Sr/Nr 047087 and before	
44		696215-22830	2	CORD, NYLON(2.4*2.5)		Drive Shaft Sr/Nr 047087 and before	

11. Gear Case(Loop Handle Type), Nylon Line Cutting Head

No.11

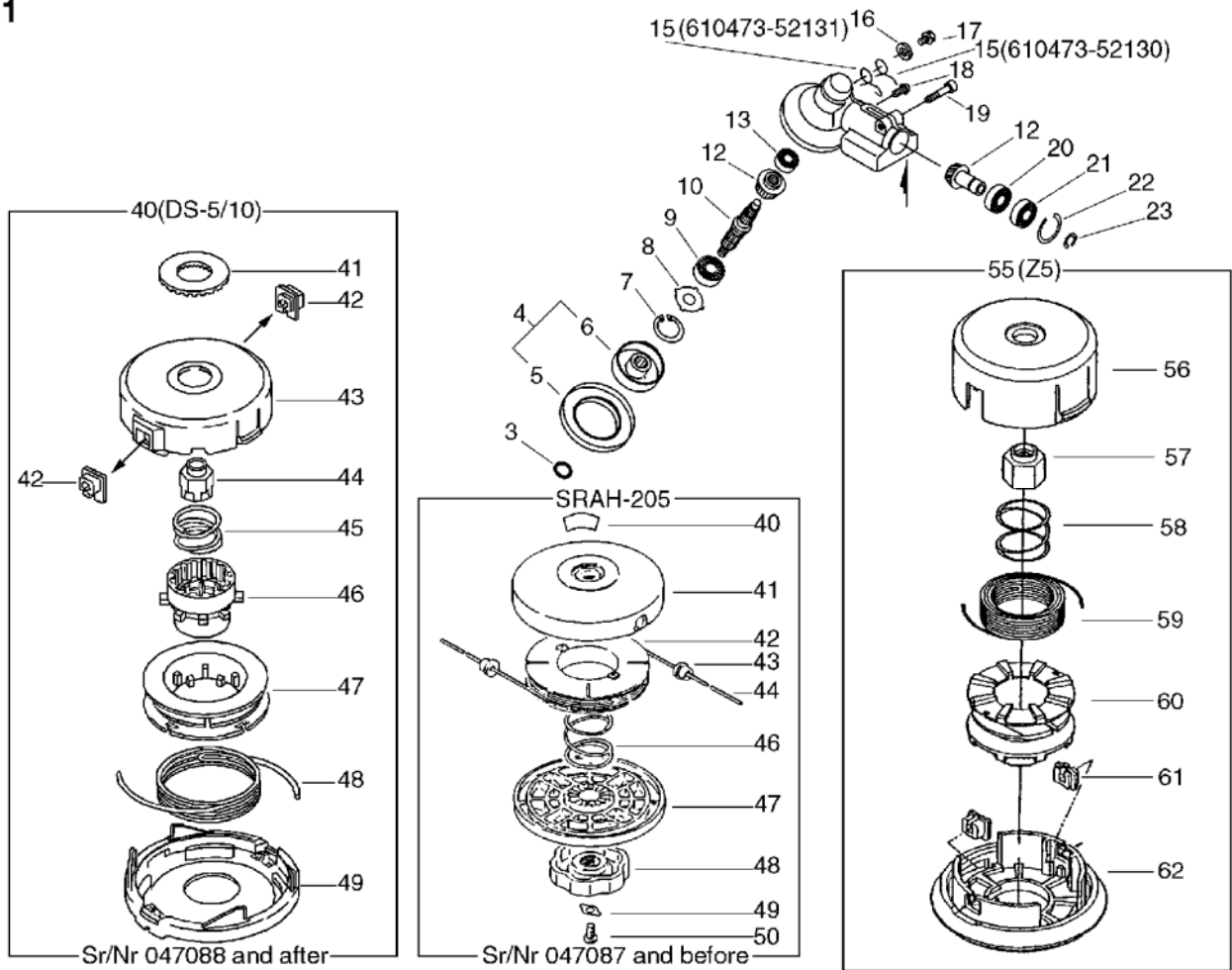

KEY	LV	PART NUMBER	Q'TY	DESCRIPTION	REMARKS	NOTE1	NOTE2
46		696216-06030	1	SPRING		Drive Shaft Sr/Nr 047087 and before	
47		696206-28232	1	COVER, DRUM (BL)		Drive Shaft Sr/Nr 047087 and before	
48		696219-28231	1	NUT (BL)		Drive Shaft Sr/Nr 047087 and before	
49		696220-06030	1	STOPPER, NUT		Drive Shaft Sr/Nr 047087 and before	
50		900220-06010	1	SCREW 6*10	6*10	Drive Shaft Sr/Nr 047087 and before	
40		X047-000070	1	CUTTER,ASM LINE	DS-5/10	Sus. by X047-000330	
40		X047-000220	1	CUTTER,ASM LINE	DS-5 M10L	Sus. by X047-000330	
41	+	V332-000000	1	WASHER,CIRCULAR 24		Drive Shaft Sr/Nr 047088 and after	
42	+	P022-000710	2	EYELET	T4	Drive Shaft Sr/Nr 047088 and after	

11. Gear Case(Loop Handle Type), Nylon Line Cutting Head

No.11

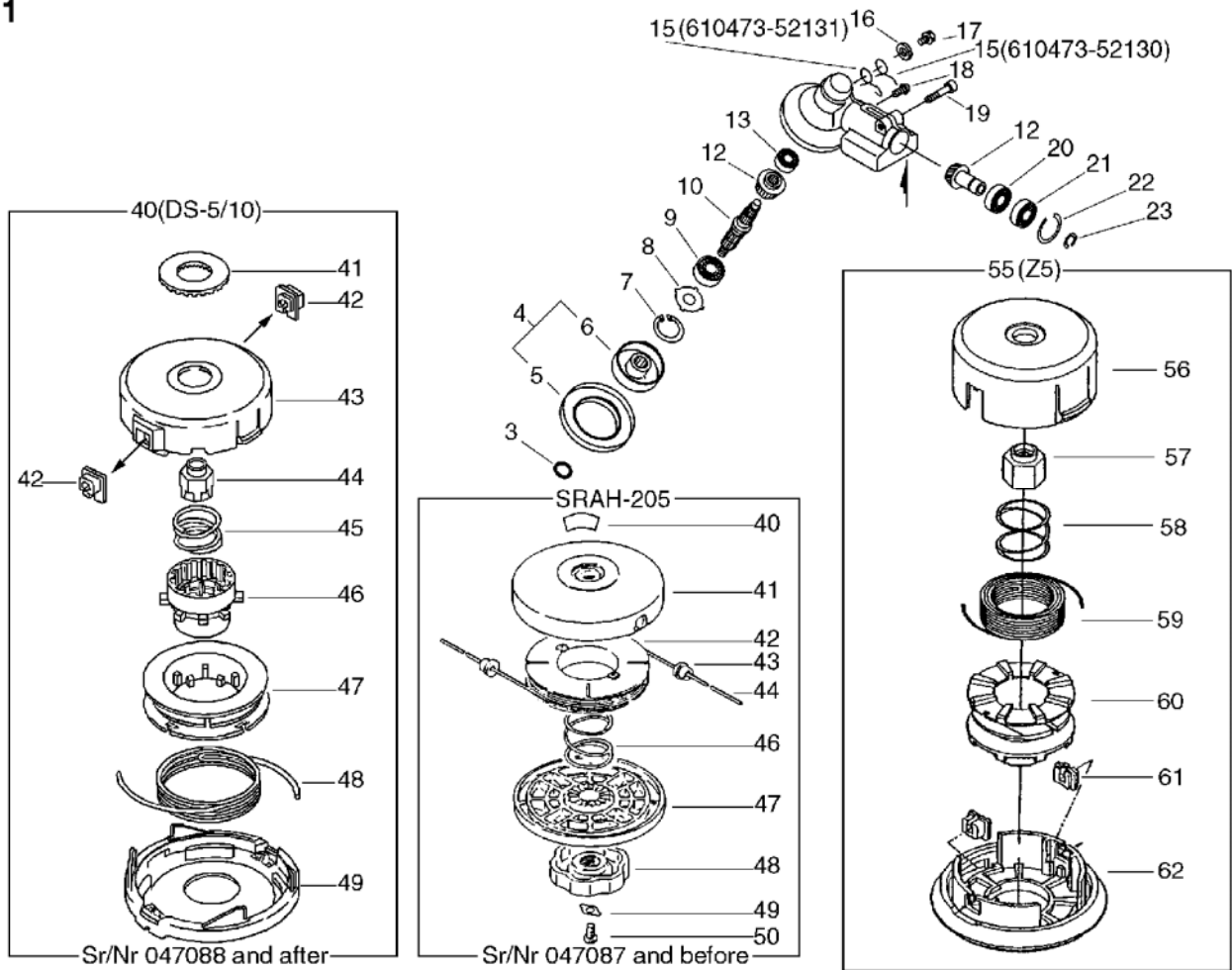

KEY	LV	PART NUMBER	Q'TY	DESCRIPTION	REMARKS	NOTE1	NOTE2
43	+	X470-000000	1	DRUM,REEL		Sus. by P022-005040	
43	+	P022-005040	1	HOUSING		Drive Shaft Sr/Nr 047088 and after	
44	+	P022-001160	1	NUT		Drive Shaft Sr/Nr 047088 and after	
45	+	P022-001200	1	SPRING	DS-5/10	Drive Shaft Sr/Nr 047088 and after	
46	+	P022-001310	1	TAP KNOB	DS-5/10	Drive Shaft Sr/Nr 047088 and after	
47	+	P022-001180	1	BOBBIN	DS-5/10	Drive Shaft Sr/Nr 047088 and after	
48	+	P022-000730	1	NYLON CODE	2.4*3M B4-K	Sus. by P022-006200	
48	+	P022-006200	1	NYLON CODE	3.0*3M	Drive Shaft Sr/Nr 047088 and after	
49	+	P022-001190	1	COVER	DS-5/10	Sus. by P022-005030	

11. Gear Case(Loop Handle Type), Nylon Line Cutting Head

No.11

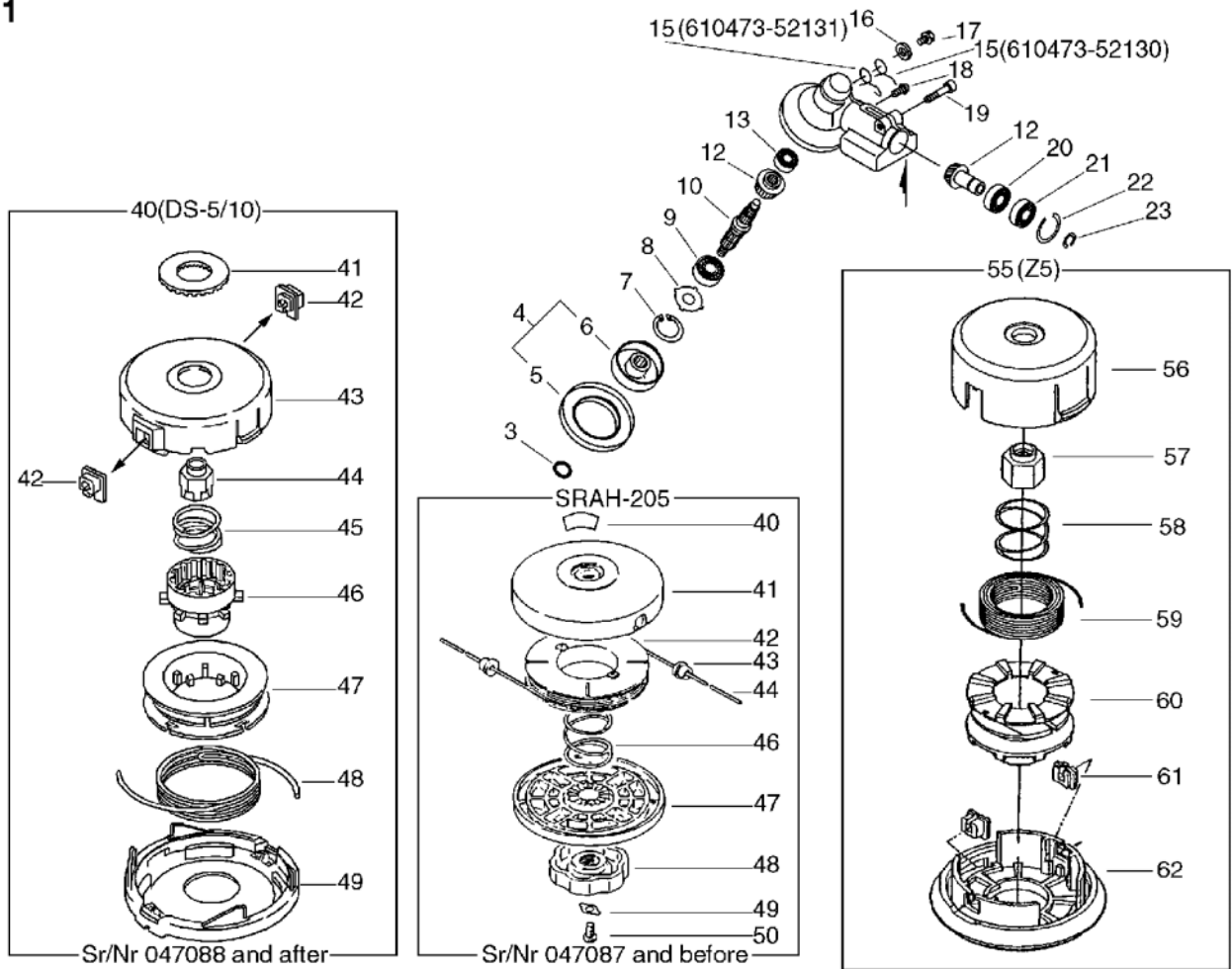

KEY	LV	PART NUMBER	Q'TY	DESCRIPTION	REMARKS	NOTE1	NOTE2
49	+	P022-005030	1	COVER		Drive Shaft Sr/Nr 047088 and after	
55		X047-000330	1	CUTTER,ASM LINE	Z-5 M10 L		
56	+	P022-010420	1	HOUSING			
57	+	P022-010390	1	NUT			
58	+	P022-010370	1	SPRING			
59	+	P022-010380	1	NYLON CODE			
60	+	P022-010400	1	BOBBIN			
61	+	P022-000710	2	EYELET	T4		
62	+	P022-010410	1	COVER			

12. Carburetor

No.12

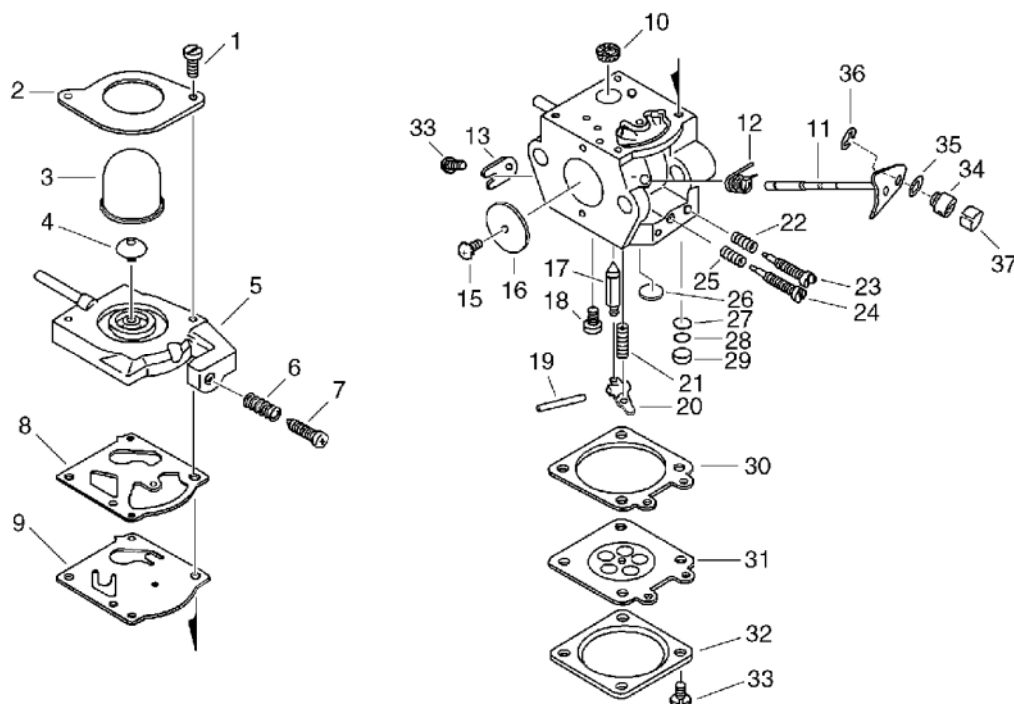

KEY	LV	PART NUMBER	Q'TY	DESCRIPTION	REMARKS	NOTE1	NOTE2
		123000-51430	1	CARBURETOR ASSY	WT-297		
1	+	123110-43130	2	SCREW			
2	+	123142-09560	1	COVER, PRIMER PUMP			
3	+	123181-09560	1	PUMP, PRIMER			
4	+	123171-35630	1	VALVE, CHECK			
5	+	123124-43130	1	COVER, FUEL PUMP			
6	+	123133-04260	1	SPRING, IDLE ADJUST			
7	+	123134-04260	1	SCREW, IDLE ADJUST			
8	+	123125-09560	1	GASKET, FUEL PUMP			
9	+	123112-09560	1	DIAPHRAGM, FUEL PUMP			
10	+	123126-10631	1	SCREEN, INLET			
11	+	123117-05020	1	SHAFT, THROTTLE			
12	+	123113-15030	1	SPRING, THRT. RETURN			
13	+	123127-03930	1	CLIP, THROTTLE SHAFT			
15	+	123114-03930	1	SCREW		Sr/Nr 002319 and before	
15	+	123114-38830	1	SCREW		Sr/Nr 002320 and after	
16	+	123116-10530	1	VALVE, THROTTLE			
17	+	123137-04260	1	VALVE, INLET NEEDLE			
18	+	123139-03930	1	SCREW, M. LEVER PIN			
19	+	123138-03930	1	PIN, METERING LEVER			
20	+	123123-03930	1	LEVER, METERING			
21	+	123122-06530	1	SPRING, METER. LEVER			
22	+	123119-22130	1	SPRING, NEEDLE			
23	+	123120-51430	1	NEEDLE, HIGH SPEED			

12. Carburetor

No.12

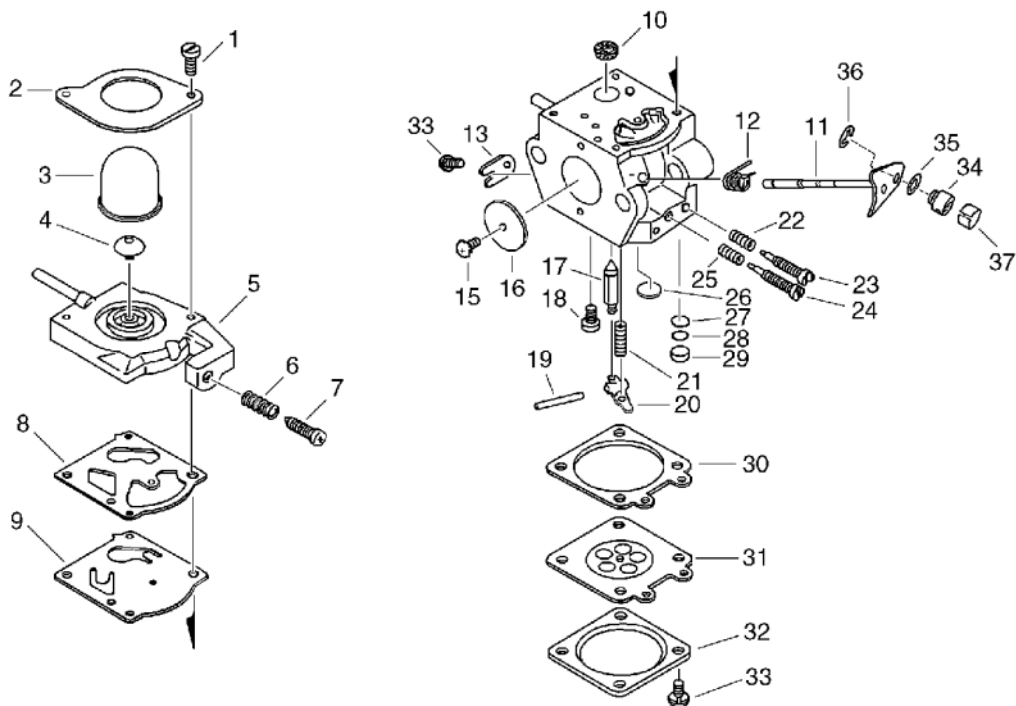

KEY	LV	PART NUMBER	Q'TY	DESCRIPTION	REMARKS	NOTE1	NOTE2
24	+	123118-37330	1	NEEDLE, IDLE			
25	+	123121-22130	1	SPRING, NEEDLE			
26	+	123146-10631	1	PLUG, WELCH			
27	+	123168-10631	1	SCREEN			
28	+	123169-10630	1	RING, RETAINING			
29	+	123146-17330	1	PLUG, CUP			
30	+	123140-03930	1	GASKET, M. DIAPHRAGM			
31	+	123141-03930	1	DIAPHRAGM, METERING			
32	+	123142-03930	1	COVER, M. DIAPHRAGM			
33	+	123130-02960	5	SCREW			
34	+	123172-26030	1	SWIVEL			
35	+	123149-26030	1	WASHER			
36	+	123173-07930	1	CLIP			
37		101121-56430	1	SPRING, FLAT			

Index

Patrs Number	Key No.	Patrs Number	Key No.	Patrs Number	Key No.
100000-43130	1 - 8	123142-09560	12 - 2	159112-09961	8 - 13
100000-43131	1 - 8	123146-10631	12 - 26	159905-43130	1 - 2
100011-42230	1 - 9	123146-17330	12 - 29	162021-42230	3 - 5
100012-12331	1 - 12	123149-26030	12 - 35	163400-49330	10 - 23
100012-27930	1 - 12	123168-10631	12 - 27	163401-43130	8 - 9
100013-00410	1 - 10	123169-10630	12 - 28	175005-43130	3 - 19
100014-17330	1 - 13	123171-35630	12 - 4	175009-42231	3 - 15
100015-00120	1 - 11	123172-26030	12 - 34	175018-42230	3 - 16
100100-43130	1 - 14	123173-07930	12 - 36	175046-06230	3 - 18
100142-12330	1 - 15	123181-09560	12 - 3	175048-03920	3 - 17
100204-42230	1 - 16	129006-43130	4 - 15	175049-03920	3 - 14
100212-27930	1 - 17	130016-06232	4 - 8	177200-43130	2 - 11
100213-02830	1 - 24	130016-42231	4 - 5	177202-41030	2 - 5
100215-02830	1 - 18	130017-43130	4 - 6	177214-41030	2 - 13
100242-42230	1 - 21	130111-00530	5 - 14	177215-43130	2 - 14
101010-42231	1 - 7	130301-43130	4 - 11	177218-40630	2 - 9
101011-43130	1 - 5	130302-43132	4 - 18	177220-40630	2 - 15
101121-56430	12 - 37	130310-43130	4 - 17	177226-01110	2 - 17
101511-42230	1 - 27	130415-40630	4 - 20	177227-05530	2 - 18
101514-42230	1 - 4	131004-55530	5 - 2	177227-42030	2 - 18
101534-42230	1 - 26	131010-46930	5 - 8	177228-11120	2 - 19
123000-51430	12 -	131010-46931	5 - 8	177234-40630	2 - 8
123000-51430	4 - 9	131016-55830	5 - 3	177236-40630	2 - 12
123110-43130	12 - 1	131051-56030	5 - 4	178001-12620	10 - 7
123112-09560	12 - 9	131205-19830	5 - 17	178001-43230	8 - 11
123113-15030	12 - 12	131300-56430	5 - 13	178003-51830	10 - 17
123114-03930	12 - 15	131328-40630	5 - 12	178010-05960	8 - 7
123114-38830	12 - 15	131910-43130	5 - 10	178010-52130	10 - 21
123116-10530	12 - 16	131923-11120	5 - 7	178012-05960	8 - 5
123117-05020	12 - 11	131924-43130	5 - 9	178012-52630	10 - 20
123118-37330	12 - 24	132010-13930	5 - 15	178013-35631	8 - 6
123119-22130	12 - 22	132010-51230	5 - 5	178013-52630	10 - 26
123120-51430	12 - 23	132010-56330	5 - 6	178043-42230	10 - 22
123121-22130	12 - 25	132013-09820	5 - 19	178090-52630	10 - 25
123122-06530	12 - 21	132115-46730	5 - 18	178090-52631	10 - 25
123123-03930	12 - 20	145510-42231	5 - 20	178090-52632	10 - 25
123124-43130	12 - 5	145610-43130	5 - 22	178127-43130	10 - 8
123125-09560	12 - 8	145866-43131	5 - 25	178127-43230	8 - 12
123126-10631	12 - 10	145867-43131	5 - 26	178510-47530	4 - 10
123127-03930	12 - 13	145871-43130	5 - 28	178515-43130	4 - 13
123130-02960	12 - 33	156112-40630	3 - 4	178516-00830	4 - 14
123133-04260	12 - 6	156601-12920	3 - 8	178810-05230	4 - 12
123134-04260	12 - 7	156626-42230	3 - 8	224924-52930	8 - 14
123137-04260	12 - 17	156635-43130	3 - 6	301000-55230	10 - 31
123138-03930	12 - 19	156801-42230	3 - 10	301000-55231	10 - 31
123139-03930	12 - 18	159011-03432	3 - 2	301001-56830	8 - 34
123140-03930	12 - 30	159012-03433	3 - 3	301001-56831	8 - 34
123141-03930	12 - 31	159017-10230	3 - 1	301015-05330	8 - 16
123142-03930	12 - 32	159112-09960	8 - 13	301200-05230	8 - 15

Index

Patrs Number	Key No.	Patrs Number	Key No.	Patrs Number	Key No.
301200-42230	10 - 15	610903-40430	3 - 27	898510-39130	7 - 6
301207-07530	10 - 12	610910-40430	3 - 26	898562-43230	9 - 34
301210-04630	8 - 18	610910-51830	3 - 26	899580-40930	7 - 5
301305-24330	10 - 32	610910-55630	3 - 26	899580-68730	7 - 5
351010-52930	8 - 29	610922-43130	3 - 29	900100-05018	10 - 13
351010-52931	8 - 29	610922-55630	3 - 28	900105-05012	8 - 17
351102-47530	8 - 1	695001-55631	9 - 32	900141-05012	9 - 41
351201-55630	10 - 2	696001-55631	9 - 31	900142-05025	3 - 30
351202-51430	8 - 26	696206-28232	11 - 47	900162-04020	2 - 20
351213-51830	10 - 27	696210-56930	11 - 41	900162-05014	6 - 28
351214-52930	8 - 25	696212-06032	11 - 43	900162-05018	6 - 27
351214-52931	8 - 25	696214-06830	11 - 42	900162-05020	1 - 6
351301-52930	8 - 19	696215-22830	11 - 44	900162-05020	3 - 23
351311-22430	8 - 30	696216-06030	11 - 46	900162-05020	5 - 23
351421-52130	8 - 20	696219-28231	11 - 48	900162-05020	8 - 22
605014-54230	8 - 21	696220-06030	11 - 49	900162-05020	8 - 27
610011-06230	10 - 10	699000-52930	6 - 25	900162-05025	1 - 28
610011-06230	8 - 33	699000-52931	6 - 25	900162-05025	3 - 30
610203-43130	3 - 24	699010-52930	6 - 34	900162-05025	4 - 7
610205-43130	3 - 25	699010-52931	6 - 34	900162-05025	6 - 29
610205-43131	3 - 25	699012-03330	10 - 14	900162-05025	7 - 23
610206-43130	10 - 30	699013-52130	6 - 26	900162-05030	1 - 23
610206-43130	8 - 32	699013-56830	6 - 30	900162-05030	8 - 23
610272-51830	10 - 28	699013-56830	7 - 22	900162-06030	11 - 19
610281-42230	10 - 5	699016-52130	6 - 31	900162-06030	9 - 19
610300-56930	11 - 12	699016-54530	6 - 31	900220-05030	8 - 3
610300-56930	9 - 12	699200-56830	9 - 35	900220-06010	11 - 50
610310-56930	11 - 10	699226-05430	9 - 37	900238-04010	1 - 25
610310-56930	9 - 10	699227-04630	9 - 39	900238-04010	5 - 27
610313-52930	11 - 4	699228-08930	9 - 40	900238-05010	1 - 3
610313-52930	9 - 6	699229-56830	9 - 3	900238-05010	3 - 7
610313-56830	9 - 36	890118-49330	2 - 21	900238-05014	1 - 1
610314-52130	9 - 4	890121-47530	4 - 21	900238-05014	5 - 11
610320-52130	9 - 2	890152-04930	10 - 33	900238-05014	5 - 29
610352-56830	11 - 5	890152-04930	8 - 40	900238-05020	3 - 9
610352-56830	9 - 11	890157-39130	10 - 11	900242-05010	11 - 18
610400-56930	9 - 1	890157-39130	8 - 35	900242-05010	9 - 18
610400-56931	9 - 1	890177-46730	10 - 1	900242-05014	10 - 16
610400-56932	9 - 1	890611-43030	1 - 29	900242-05018	7 - 17
610434-50030	11 - 17	890617-43130	10 - 1	900242-05025	10 - 19
610434-50030	9 - 17	890617-43130	8 - 31	900242-05028	10 - 29
610434-50031	11 - 17	890617-46730	11 - 40	900242-05035	10 - 3
610434-50031	9 - 17	890617-46830	8 - 31	900242-05035	10 - 18
610444-56830	11 - 8	890617-63630	10 - 1	900242-05057	4 - 16
610444-56830	9 - 8	895112-00330	7 - 2	900246-03025	8 - 2
610473-52130	11 - 15	895410-08030	7 - 3	900246-04016	8 - 2
610473-52130	9 - 15	895610-00130	7 - 1	900252-05012	7 - 13
610473-52131	11 - 15	897518-01131	7 - 4	900253-04016	8 - 2
610473-52131	9 - 15	898503-50030	9 - 33	900253-04025	10 - 6

Index

Patrs Number	Key No.	Patrs Number	Key No.	Patrs Number	Key No.
900500-00005	10 - 4	C062-000181	8 - 34	V430-000400	8 - 11
900500-00005	10 - 24	C403-000030	8 - 30	V452-000050	8 - 6
900500-00005	10 - 24	C403-000031	8 - 30	V452-000060	8 - 8
900500-00005	4 - 4	C450-000020	8 - 7	V471-001190	5 - 15
900500-00005	6 - 33	C450-000021	8 - 7	X047-000070	11 - 40
900500-00005	8 - 4	C460-000010	8 - 5	X047-000220	11 - 40
900500-00005	8 - 28	C460-000011	8 - 5	X047-000330	11 - 55
900502-00006	10 - 9	C535-000000	11 - 4	X405-000000	9 - 30
900502-00006	8 - 10	C535-000000	9 - 6	X405-000001	9 - 30
900502-00008	2 - 10	C535-000001	11 - 4	X470-000000	11 - 43
900503-00010	3 - 13	C535-000001	9 - 6	X505-000140	10 - 1
900565-00005	7 - 16	C535-000010	11 - 6	X602-000020	7 - 3
900565-50008	8 - 24	C535-000010	9 - 14		
900600-00006	3 - 31	C535-000011	11 - 6		
900600-00010	3 - 11	C535-000011	9 - 14		
900603-00005	6 - 32	C550-000080	7 - 11		
900603-50008	11 - 16	C550-000090	7 - 21		
900603-50008	9 - 16	C550-000100	7 - 20		
900605-00010	3 - 12	C554-000000	7 - 12		
900700-00004	2 - 6	P021-000150	3 - 27		
900701-00012	11 - 23	P021-002610	8 - 1		
900701-00012	3 - 22	P021-002611	8 - 1		
900701-00012	9 - 23	P021-002612	8 - 1		
900702-00028	11 - 22	P021-002620	7 - 10		
900702-00028	3 - 20	P021-002760	8 - 19		
900702-00028	9 - 22	P021-002761	8 - 19		
900702-00032	11 - 7	P021-002861	7 - 5		
900702-00032	9 - 7	P021-007470	9 - 33		
900702-00035	1 - 22	P022-000710	11 - 42		
900720-00004	4 - 19	P022-000710	11 - 61		
900720-00012	11 - 3	P022-000730	11 - 48		
900720-00012	9 - 5	P022-001160	11 - 44		
900800-06001	11 - 20	P022-001180	11 - 47		
900800-06001	9 - 20	P022-001190	11 - 49		
900803-06001	11 - 21	P022-001200	11 - 45		
900803-06001	9 - 21	P022-001310	11 - 46		
900807-06001	11 - 21	P022-005030	11 - 49		
900807-06001	3 - 21	P022-005040	11 - 43		
900807-06001	9 - 21	P022-006200	11 - 48		
900810-00629	11 - 13	P022-010370	11 - 58		
900810-00629	9 - 13	P022-010380	11 - 59		
900810-36201	1 - 19	P022-010390	11 - 57		
900810-36202	1 - 20	P022-010400	11 - 60		
900812-06201	11 - 9	P022-010410	11 - 62		
900812-06201	9 - 9	P022-010420	11 - 56		
900814-06202	9 - 38	V162-000130	8 - 41		
94035-36201	1 - 19	V299-000110	8 - 20		
A051-000170	2 - 11	V307-000050	1 - 13		
C062-000180	8 - 34	V332-000000	11 - 41		

YAMABIKO CORPORATION

7-2 SUEHIROCHO 1-CHOME, OHME, TOKYO 198-8760, JAPAN
PHONE: 81-428-32-6118. FAX: 81-428-32-6145.



3805
No.