



PARTS CATALOGUE

GRASS-TRIMMER / BRUSHCUTTER

SRM-2600

1. Cylinder, Crankcase, Piston

No.1

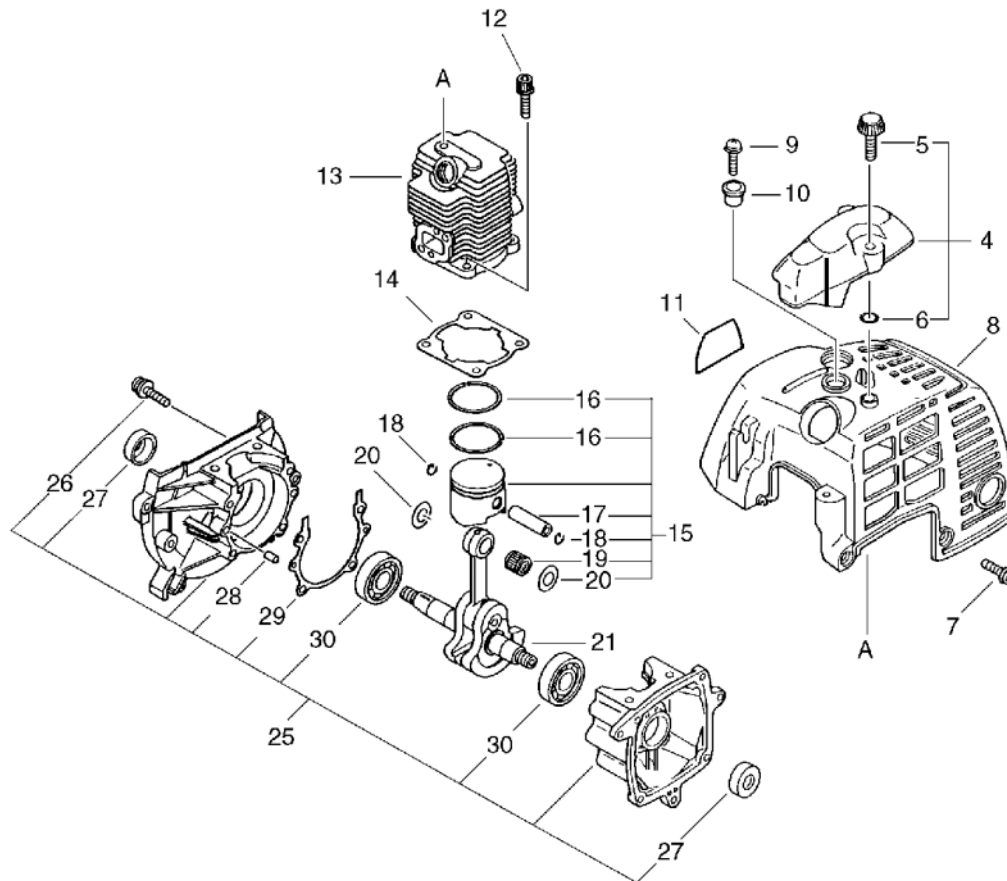

KEY	LV	PART NUMBER	Q'TY	DESCRIPTION	REMARKS	NOTE1	NOTE2
4		159902-55230	1	GUARD KIT, TOP			
5	+	352325-55230	1	KNOB, FASTENER			
6	+	900720-00004	1	O-RING (P-4)	P-4		
7		900238-05012	2	SCREW 5*12	5*12		
8		101514-55230	1	COVER, CYLINDER			
9		900238-05020	1	SCREW 5*20	5*20		
10		101531-55230	1	COLLAR			
11		890112-55230	1	LABEL, MODEL			
12		900162-05020	4	BOLT, H.S. 5*20	5*20 W, SW		
13		101011-55230	1	CYLINDER			
14		101010-22331	1	GASKET, CYL. BASE			
15		100000-55230	1	PISTON KIT			
16	+	100011-05330	2	RING, PISTON			
17	+	100013-22330	1	PIN, PISTON			
18	+	100015-04630	2	CIRCLIP, PISTON PIN			
19	+	175012-03930	1	BEARING, NEEDLE			
20	+	100014-11520	2	SPACER, PISTON PIN			
21		100100-55230	1	CRANKSHAFT ASSY		Sus. by 100100-55232	
21		100100-55231	1	CRANKSHAFT		Sus. by 100100-55232	
21		100100-55232	1	CRANKSHAFT			
25		100204-55230	1	CRANKCASE KIT		Sus. by 100204-55231	
25		100204-55231	1	CRANKCASE KIT			
26	+	900242-05028	4	SCREW 5*28	5*28		

1. Cylinder, Crankcase, Piston

No.1

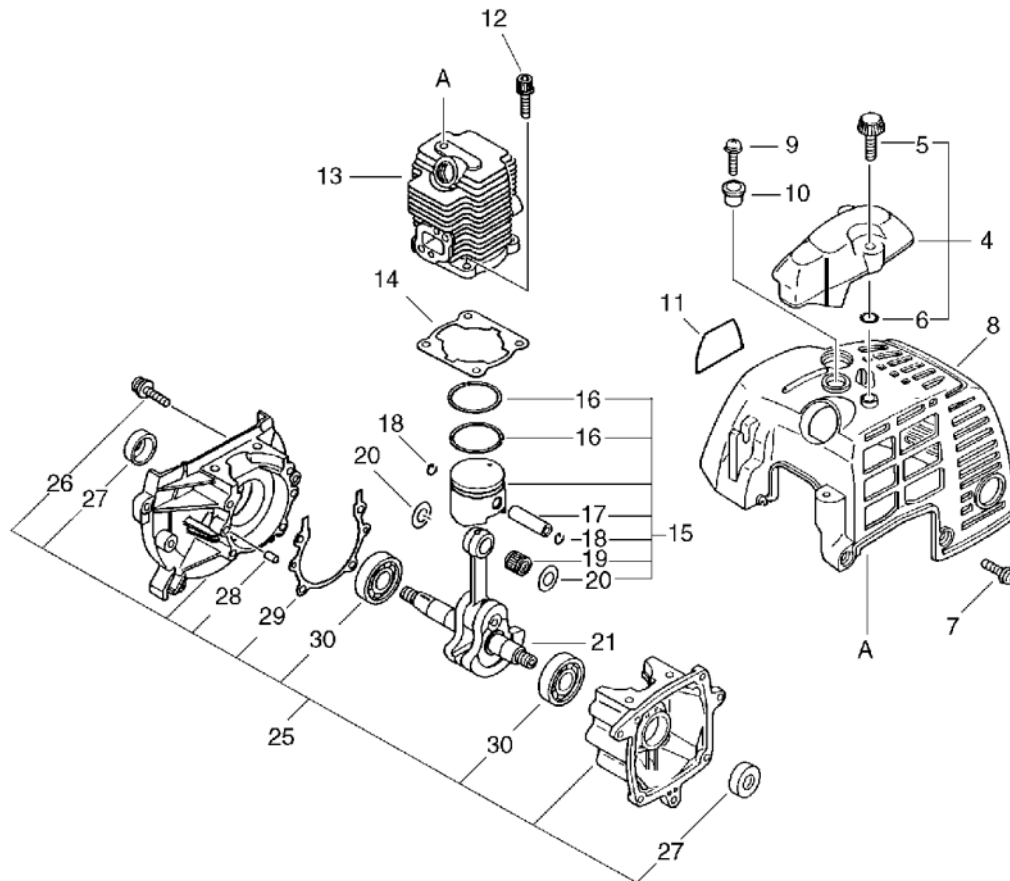

KEY	LV	PART NUMBER	Q'TY	DESCRIPTION	REMARKS	NOTE1	NOTE2
27	+	100212-42030	2	OILSEAL	ISCD12*22*4.5	Sus. by 100212-42031	
27	+	100212-42031	2	OILSEAL	ISCD 12*22*4.5		
28	+	100215-03930	4	PIN, DOWEL			
29	+	100242-55230	1	GASKET, CRANKCASE			
30	+	900810-36201	2	BEARING, BALL 6201	6201/C3	Sus. by 94035-36201	
30	+	94035-36201	2	BEARING BALL	6201X3JR2C3		

2. Starter, Magneto, Clutch

No.2

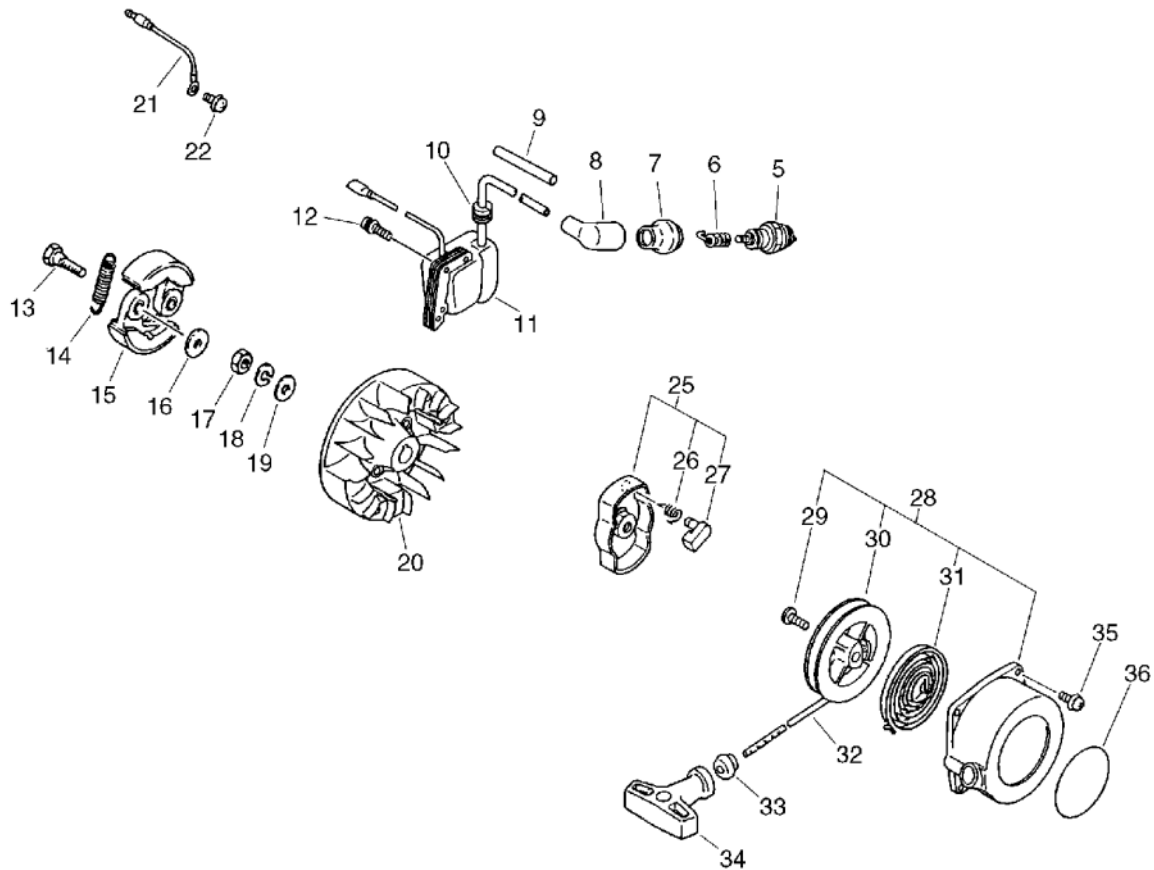

KEY	LV	PART NUMBER	Q'TY	DESCRIPTION	REMARKS	NOTE1	NOTE2
5		159010-10230	1	PLUG, SPARK (BPMR-7A)	BPMR-7A		
6		159011-03432	1	COIL, SPARK PLUG			
7		159015-55230	1	COVER, PLUG CAP			
8		159012-01620	1	CAP, SPARK PLUG			
9		156111-55230	1	TUBE	6*7*100		
10		150112-44330	1	BUSHING			
11		156626-55230	1	COIL, IGNITION		Sus. by 156626-55231	
11		156626-55231	1	COIL, IGNITION			
12		900238-04022	2	SCREW 4*22	4*22		
13		175046-22332	2	BOLT, CLUTCH			
14		175018-05535	1	SPRING, CLUTCH			
15		175009-05532	2	SHOE, CLUTCH			
16		175048-05530	2	WASHER (I)	6.2*19*1.0		
17		900502-00008	1	NUT 8 (3N)	3N8		
18		900605-00008	1	WASHER, SPRING 8	8		
19		900600-00008	1	WASHER 8	8		
20		156801-55230	1	FLYWHEEL		Sus. by 156801-55231	
20		156801-55231	1	FLYWHEEL			
21		162014-27230	1	LEAD, GROUND			
22		900238-05010	1	SCREW 5*10	5*10		
25		177202-55230	1	PAWL ASSY, STARTER			
26	+	177234-40630	1	SPRING, RETURN			
27	+	177218-55230	1	PAWL, STARTER			
28		177200-55230	1	STARTER ASSY			

2. Starter, Magneto, Clutch

No.2

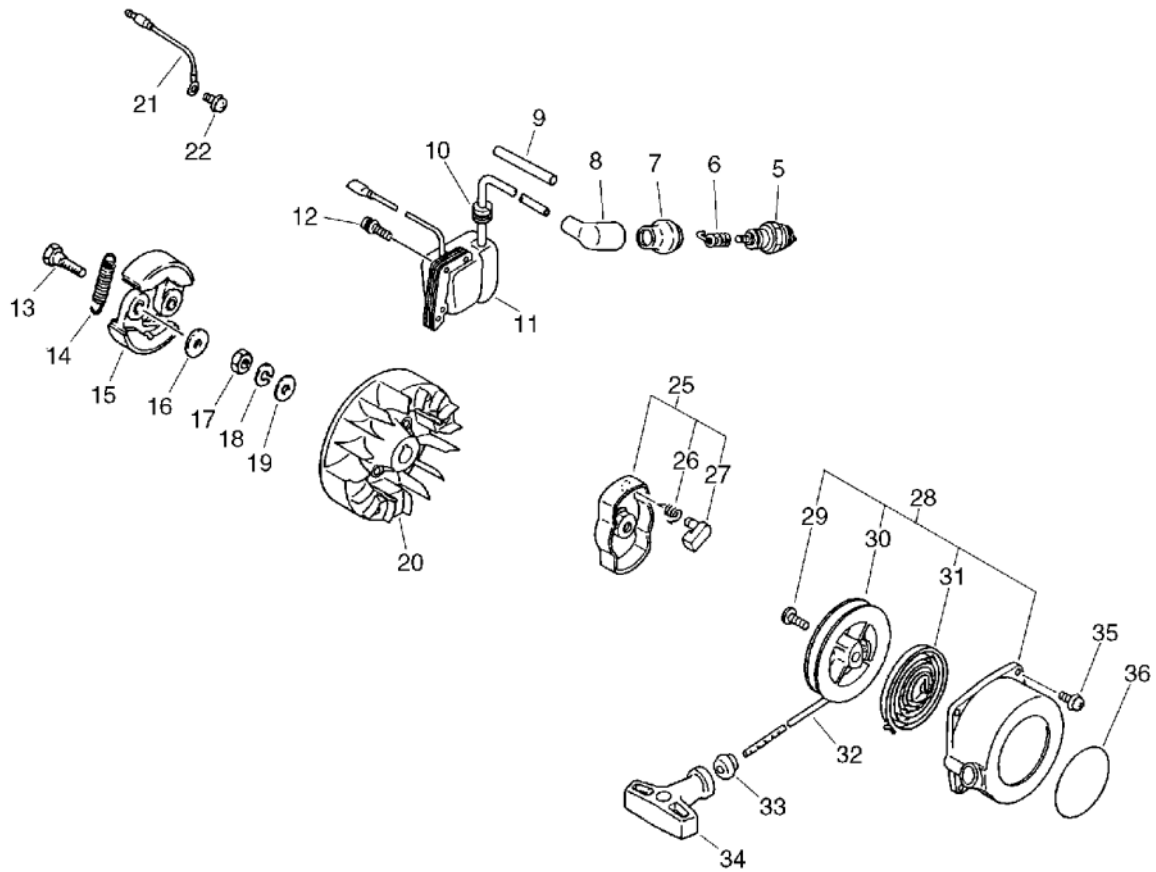

KEY	LV	PART NUMBER	Q'TY	DESCRIPTION	REMARKS	NOTE1	NOTE2
29	+	177236-40630	1	SCREW			
30	+	177215-40630	1	DRUM, STARTER			
31	+	177220-40630	1	SPRING, REWIND			
32	+	177226-40630	1	ROPE, STARTER	3.5*820		
33	+	177227-05330	1	GUIDE, ROPE			
34	+	177228-06530	1	GRIP, STARTER			
35		900238-04014	4	SCREW 4*14	4*14		
36		890118-49330	1	LABEL, ECHO			

3. Air Cleaner, Muffler

No.3

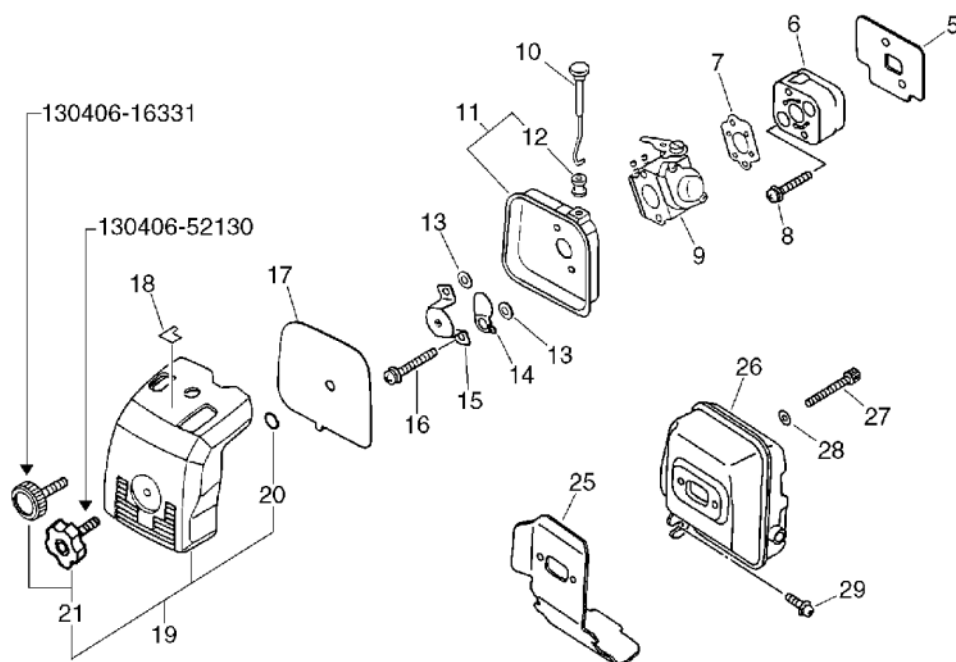

KEY	LV	PART NUMBER	Q'TY	DESCRIPTION	REMARKS	NOTE1	NOTE2
5		130010-55230	1	GASKET, INTAKE			
6		130007-51231	1	INSULATOR			
7		130016-42031	1	GASKET, INTAKE			
8		900162-05025	2	BOLT, H.S. 5*25	5*25 W,SW		
9		125200-55230	1	CARBURETOR ASSY	C1U-K36A	Sus. by 125200-55232	
9		125200-55231	1	CARBURETOR	C1U-K36A	Sus. by 125200-55232	
9		125200-55232	1	CARBURETOR C1U-K36A	C1U-K36A		
10		178510-51730	1	ROD, CHOKE			
11		130301-51730	1	CASE, AIR CLEANER			
12	+	178810-05230	1	GROMMET			
13		178516-00830	2	SPACER	5.2*8*0.8T		
14		178515-05060	1	SHUTTER, CHOKE			
15		129011-51730	1	PLATE			
16		900238-05050	2	SCREW 5*50	5*50		
17		130310-51730	1	FILTER, AIR			
18		890121-47530	1	LABEL, CHOKE			
19		130302-51730	1	COVER ASSY, AIR CLN.		Sus. by 130302-52131	
19		130302-51731	1	COVER ASSY, AIR CLN.		Sus. by 130302-52131	
19		130302-52130	1	COVER ASSY, AIR CLN.		Sus. by 130302-52131	
19		130302-52131	1	COVER ASY, A.CLEANER			

3. Air Cleaner, Muffler

No.3

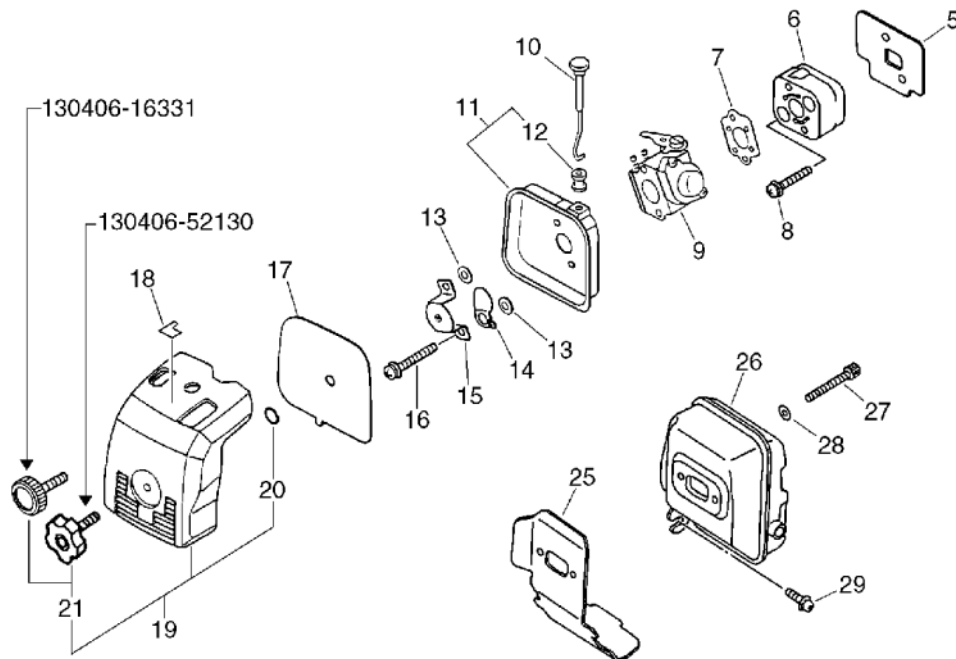

KEY	LV	PART NUMBER	Q'TY	DESCRIPTION	REMARKS	NOTE1	NOTE2
20	+	900720-00003	1	O-RING P-3	P-3	Sr/Nr 005940 and before	
21	+	130406-16331	1	NUT, THUMB		Sr/Nr 005940 and before	
21	+	130406-52130	1	KNOB, FASTENER		Sus. by 130406-52131	
21	+	130406-52131	1	KNOB, FASTENER		Sr/Nr 005941 and after	
25		145510-55230	1	GASKET, MUFFLER			
26		145610-55230	1	MUFFLER			
27		900105-05060	2	BOLT, H.S. 5*60	5*60		
28		900600-00005	2	WASHER 5	5		
29		900238-05010	1	SCREW 5*10	5*10		

4. Fuel Tank

No.4

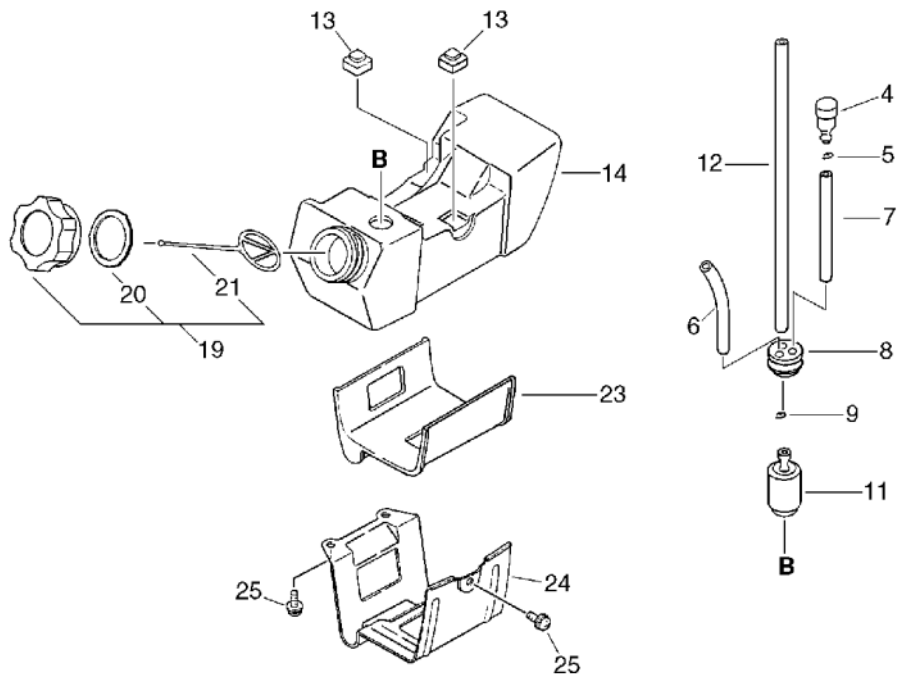

KEY	LV	PART NUMBER	Q'TY	DESCRIPTION	REMARKS	NOTE1	NOTE2
20	+	131016-55830	1	GASKET, FUEL CAP		Can be used on the 131004-08960 only	
21	+	131051-52430	1	CONNECTOR, CAP	80L		
23		131924-40930	1	CUSHION			
24		305110-40930	1	STAND (BL)			
25		900238-05010	3	SCREW 5*10	5*10		

5. Carburetor

No.5

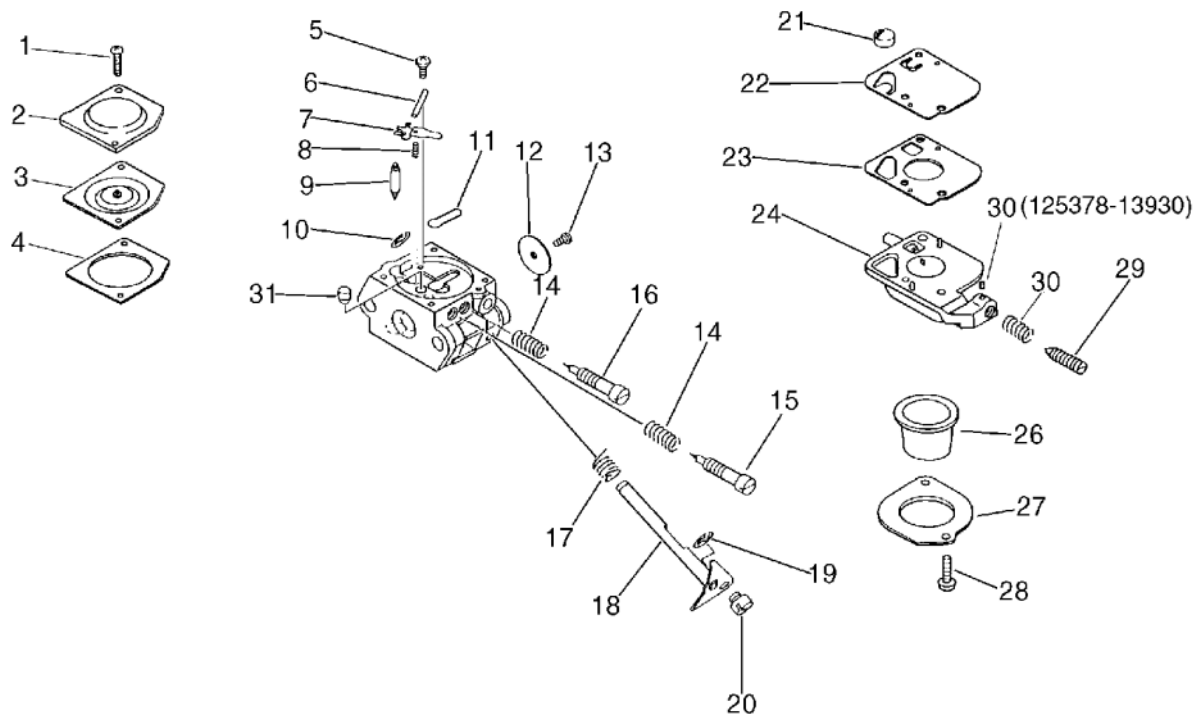

KEY	LV	PART NUMBER	Q'TY	DESCRIPTION	REMARKS	NOTE1	NOTE2
		125200-55230	1	CARBURETOR ASSY	C1U-K36A	Sus. by 125200-55232	
		125200-55231	1	CARBURETOR	C1U-K36A	Sus. by 125200-55232	
		125200-55232	1	CARBURETOR C1U-K36A	C1U-K36A		
1	+	125344-52130	2	SCREW			
2	+	125342-52130	1	COVER, DIAPHRAGM		Sus. by 125342-13210	
2	+	125342-13210	1	COVER, DIAPHRAGM			
3	+	125341-42030	1	DIAPHRAGM			
4	+	125340-42030	1	GASKET, DIAPHRAGM			
5	+	125339-42030	1	SCREW			
6	+	125338-13930	1	PIN, METERING ARM			
7	+	125323-42030	1	LEVER, METERING			
8	+	125322-12620	1	SPRING, COIL			
9	+	125337-06960	1	VALVE, INLET NEEDLE			
10	+	125327-15130	1	CLIP			
11	+	125345-15130	1	PLUG, WELCH			
12	+	125316-07260	1	VALVE, THROTTLE			
13	+	125314-13930	1	SCREW	3*4		
14	+	125319-42030	2	SPRING, COIL			
15	+	125320-51030	1	NEEDLE, HIGH SPEED			
16	+	125318-42030	1	NEEDLE, IDLE			
17	+	125313-42030	1	SPRING, THRT. RETURN			
18	+	125317-42030	1	SHAFT, THROTTLE			
19	+	125327-13930	1	CLIP			

5. Carburetor

No.5

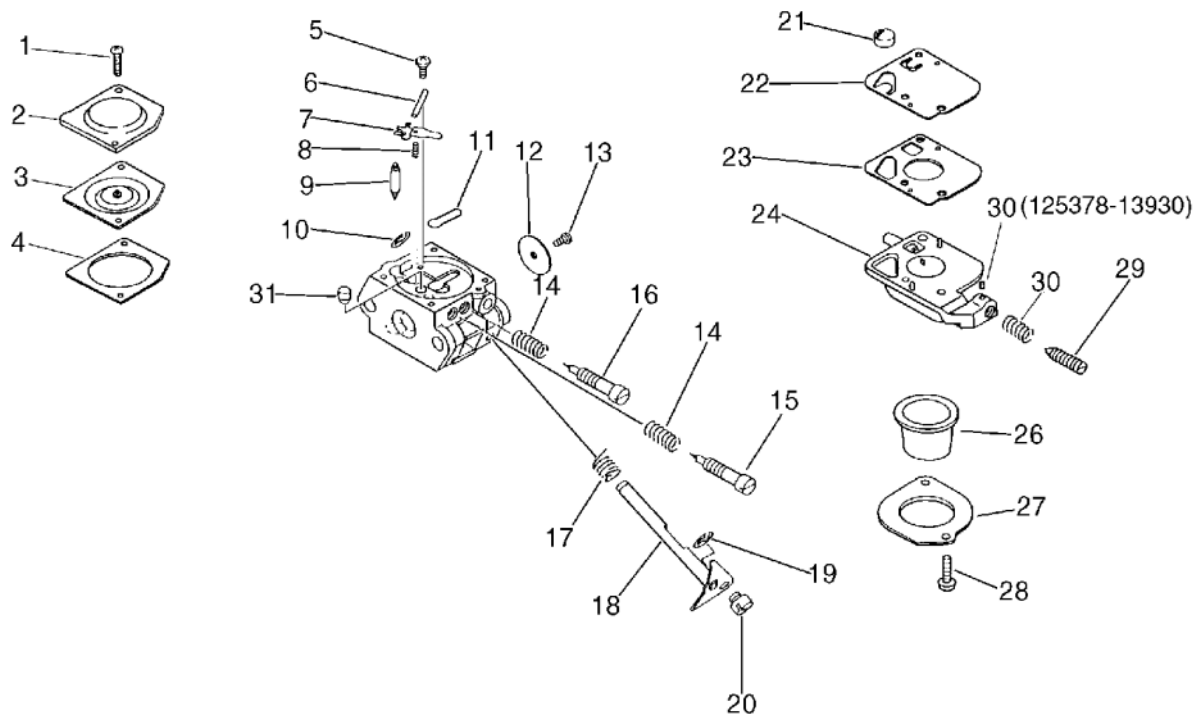

KEY	LV	PART NUMBER	Q'TY	DESCRIPTION	REMARKS	NOTE1	NOTE2
20	+	125372-42030	1	SWIVEL			
21	+	125326-42030	1	STRAINER			
22	+	125312-42030	1	DIAPHRAGM, FUEL PUMP		Can be used on the 125200-55230 only	
22	+	125312-12820	1	DIAPHRAGM, FUEL PUMP		Can be used on the 125200-55231 only	
23	+	125325-42030	1	GASKET, FUEL PUMP		Sus. by 125325- 13310	
23	+	125325-13310	1	GASKET, PUMP			
24	+	125324-11610	1	COVER, PUMP		Sus. by P005- 000990	
24	+	125383-13310	1	BASE, PRIMER		Sus. by P005- 000990	
24	+	P005-000990	1	BASE, PRIMER			
26	+	125381-46730	1	PUMP, PRIMING		Sus. by 125381- 08660	
26	+	125381-08660	1	PUMP, PRIMING			
27	+	125363-11610	1	RING			
28	+	125310-11610	2	SCREW			
29	+	125334-13930	1	SCREW, IDLE ADJUST		Can be used on the 125200-55230 only	

5. Carburetor

No.5

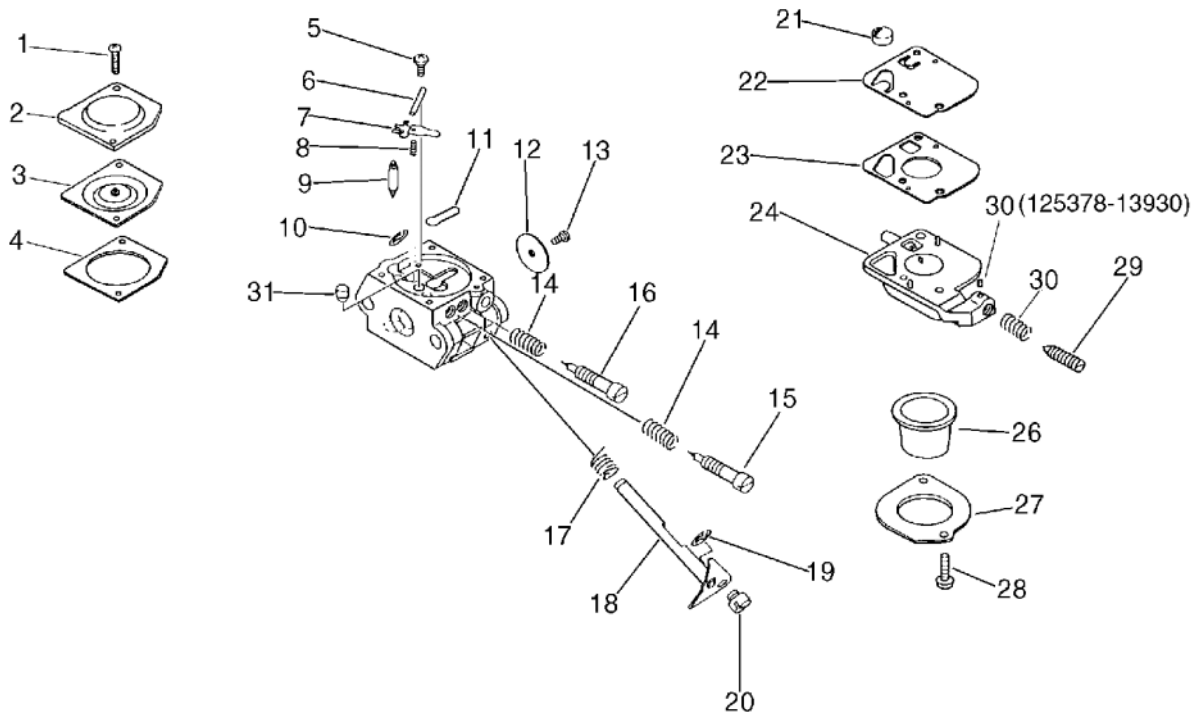

KEY	LV	PART NUMBER	Q'TY	DESCRIPTION	REMARKS	NOTE1	NOTE2
29	+	125344-08560	1	SCREW		Can be used on the 125200-55231 only	
30	+	125378-13930	1	PIECE, FRICTION		Can be used on the 125200-55230 only	
30	+	125333-08560	1	SPRING,ADJUST SCREW		Can be used on the 125200-55231 only	
31	+	125376-55230	1	NOZZLE, CHECK VALVE			

6. Fan Cover, Shield, Tools

No.6

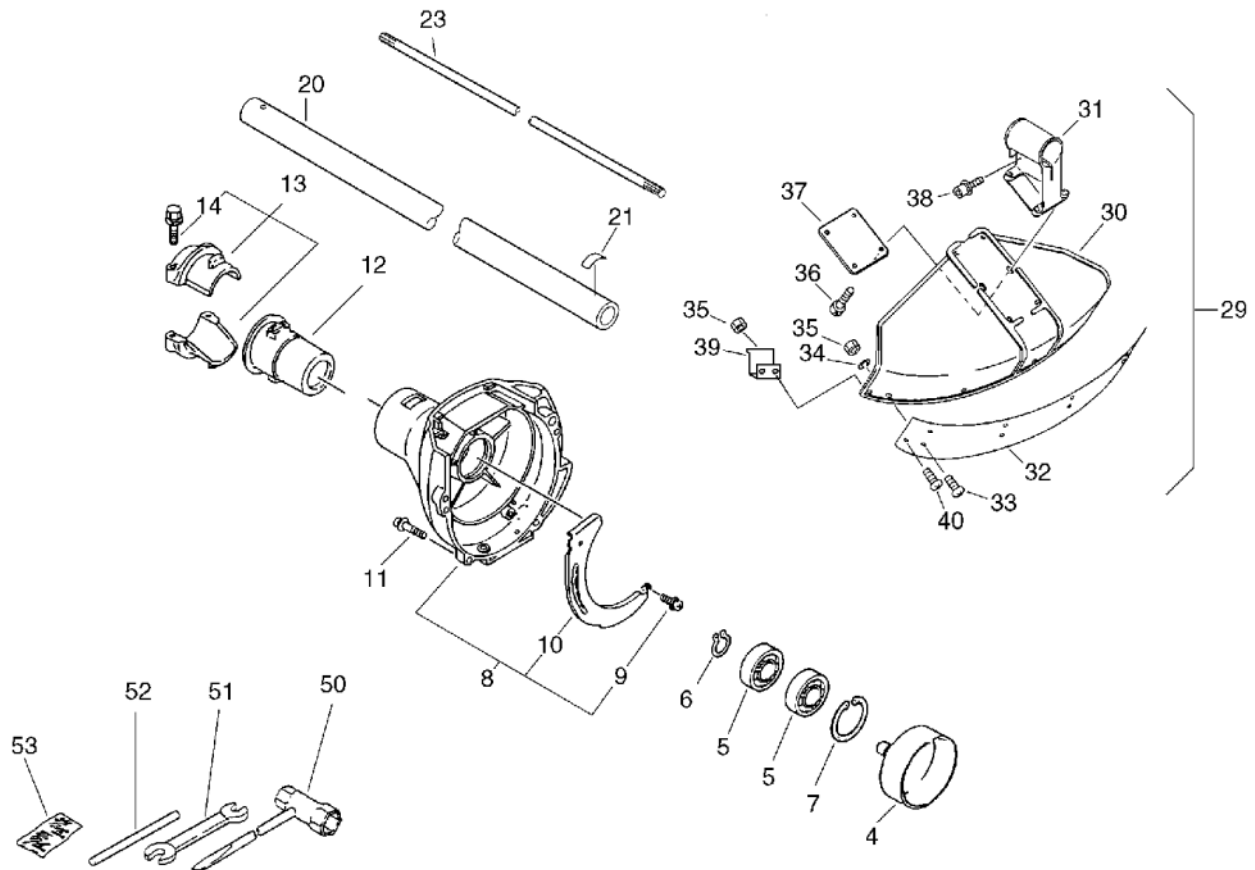

KEY	LV	PART NUMBER	Q'TY	DESCRIPTION	REMARKS	NOTE1	NOTE2
4		175005-40930	1	DRUM, CLUTCH			
5		900807-06001	2	BEARING, BALL 6001	6001V(LB)		
6		900701-00012	1	CIRCLIP 12	CS-12		
7		900702-00028	1	CIRCLIP 28	CR-28		
8		101503-55230	1	COVER ASSY, FAN			
9	+	900238-04008	2	SCREW 4*8	4*8		
10	+	101534-55230	1	PLATE, GUIDE			
11		900238-05020	4	SCREW 5*20	5*20		
12		610910-55230	1	CUSHION			
13		610903-55230	1	HOLDER KIT			
14	+	900142-05025	2	BOLT 5*25 (W/W,SW)	5*25		
20		610206-23030	1	HOUSING ASS'Y, D.SFT			
21		890152-04930	1	LABEL, CAUTION			
23		610011-25530	1	SHAFT, DRIVE			
29		699001-44730	1	SHIELD, ASSY			
30	+	699010-54430	1	SHIELD, BLADE			
31	+	699011-27230	1	BRACKET, SHIELD			
32	+	699013-52130	1	PLATE, SHIELD			
33	+	900242-05018	4	SCREW 5*18	5*18		
34	+	900603-00005	4	WASHER 5	5.5*12*0.8		
35	+	900500-00005	6	NUT 5	5		
36	+	900242-05014	4	SCREW 5*14	5*14		
37	+	699015-52130	1	PLATE, SHIELD			
38	+	900142-05025	2	BOLT 5*25 (W/W,SW)	5*25		
39	+	699016-52130	1	KNIFE, CORD		Sus. by 699016-54530	

6. Fan Cover, Shield, Tools

No.6

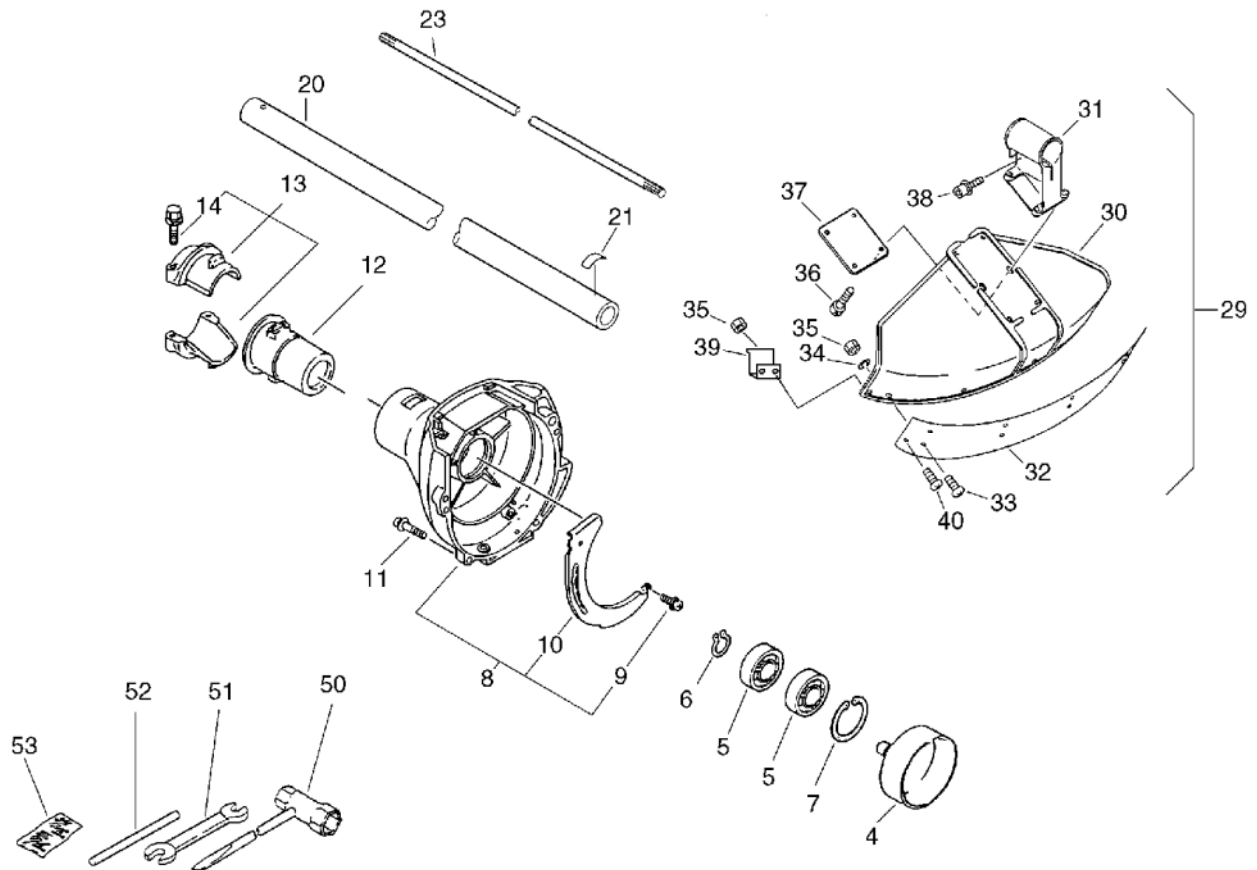

KEY	LV	PART NUMBER	Q'TY	DESCRIPTION	REMARKS	NOTE1	NOTE2
39	+	699016-54530	1	KNIFE			
40	+	900242-05012	2	SCREW 5*12	5*12		
50		895410-08030	1	WRENCH, W/S. DRIVER		Sus. by X602-000020	
50		X602-000020	1	TOOL,WRENCH	17*19 L200		
51		895112-00330	1	SPANNER 8*10			
52		897518-01131	1	LOCKING TOOL			
53		898502-01130	1	PIN 2*22 (W/POUCH)			

7. U-Handle

No.7

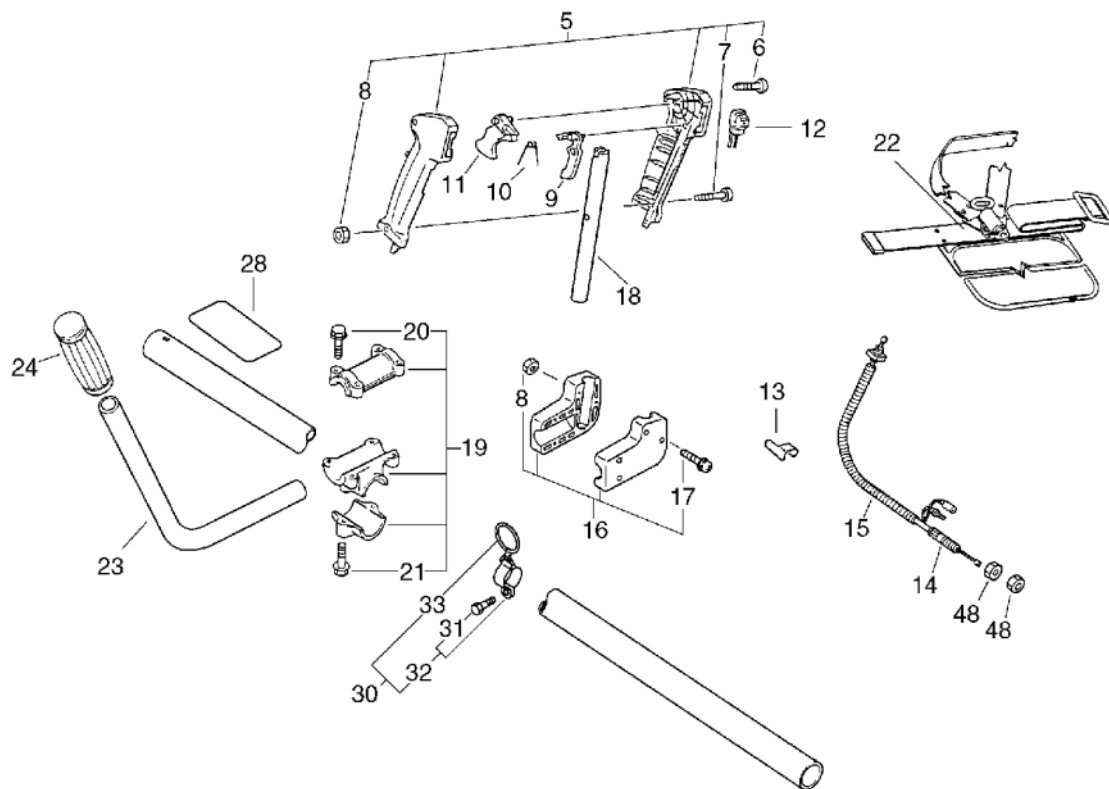

KEY	LV	PART NUMBER	Q'TY	DESCRIPTION	REMARKS	NOTE1	NOTE2
4		890157-39130	1	LABEL, SWITCH		Disuse	
5		351102-47530	1	GRIP ASSY, F-HANDLE			
6	+	900246-03025	4	SCREW 3*25	3*25		
7	+	900220-05030	1	SCREW 5*30	5*30		
8	+	900500-00005	1	NUT 5	5		
9		178012-05960	1	LOCKOUT, THROTTLE			
10		178013-35631	1	SPRING, THR. LOCK			
11		178010-05960	1	CONTROL, THROTTLE			
12		163400-48030	1	SWITCH, IGNITION			
13		178111-04930	1	CLIP			
14		178001-47530	1	WIRE, THROTTLE			
15		178127-47530	1	TUBE	7*10*760		
16		351202-51430	1	BRACKET ASSY, HANDLE			
8	+	900500-00005	4	NUT 5	5		
17	+	900242-05020	4	SCREW 5*20	5*20		
18		351210-52430	1	HANDLE, FRONT			
19		351301-09230	1	BRACKET ASS'Y, HNDL.		Sus. by P021-000460	
19		P021-000460	1	FIXTURE,ASY HANDLE			
20	+	900142-05025	4	BOLT 5*25 (W/W,SW)	5*25		
21	+	900142-06030	2	BOLT 6*30 (W/W,SW)	6*30		
22		301000-44730	1	HARNESS, SHOULDER			
23		351110-52430	1	HANDLE, FRONT			
24		351311-02330	1	GRIP, HANDLE			
28		890617-43130	1	LABEL, CAUTION			
30		301200-21330	1	HOOK ASS'Y			

7. U-Handle

No.7

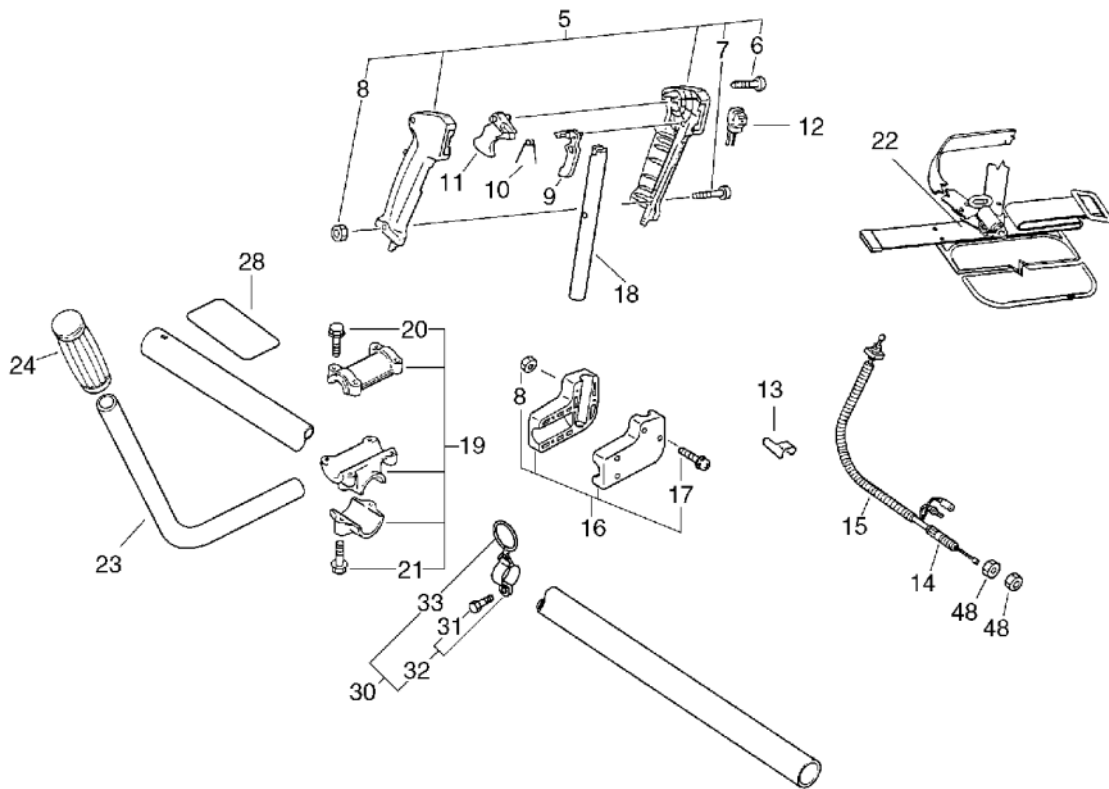

KEY	LV	PART NUMBER	Q'TY	DESCRIPTION	REMARKS	NOTE1	NOTE2
32	+	301205-21330	1	HOOK			
31	++	900100-05012	1	BOLT 5*12	5*12		
33	+	301015-05330	1	HOOK BAND			
48		900502-00006	2	NUT 6 (3N)	3N6		

8. Gear Case(U-Handle Type), Blade No.8

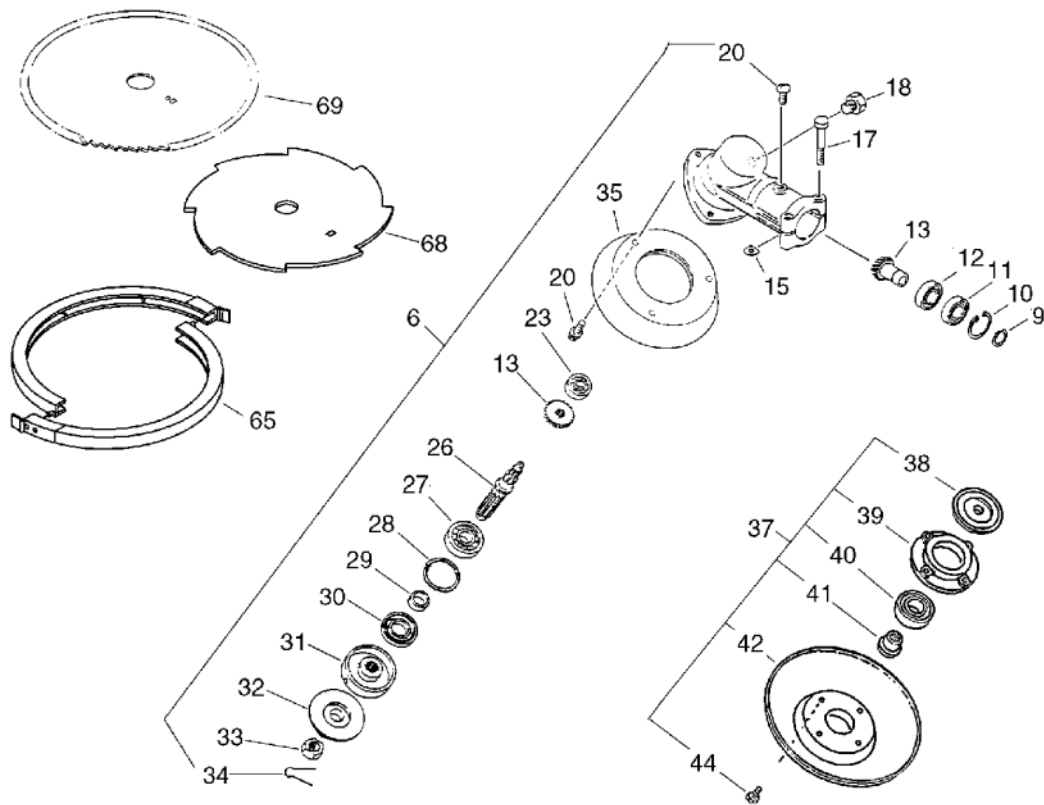

KEY	LV	PART NUMBER	Q'TY	DESCRIPTION	REMARKS	NOTE1	NOTE2
6		610400-52430	1	HOUSING ASSY, GEAR			
9	+	900706-00010	1	CIRCLIP 10	WR-10		
10	+	900702-00022	1	CIRCLIP 22	CR-22		
11	+	900858-06900	1	BEARING, BALL 6900Z	6900Z		
12	+	900855-06900	1	BEARING, BALL 6900	6900		
13	+	610300-25531	1	GEAR SET	7S		
15	+	610239-04130	2	WASHER, SHIM			
17	+	900142-05028	2	BOLT 5*28 (W/W,SW)	5*28		
18	+	610434-50030	1	BOLT 8*6		Sus. by 610434-50031	
18	+	610434-50031	1	BOLT 8*8	M8*8		
20	+	900242-05010	4	SCREW 5*10	5*10		
23	+	900810-00626	1	BEARING, BALL 626	626		
26	+	610310-40830	1	SHAFT, P.T.O.			
27	+	900800-06000	1	BEARING, BALL 6000	6000		
28	+	900702-00026	1	CIRCLIP 26	CR-26		
29	+	610315-22830	1	SPACER			
30	+	610413-22830	1	OILSEAL			
31	+	610313-22830	1	PLATE, ADAPTER (U)			
32	+	610314-27230	1	PLATE, ADAPTER			
33	+	900511-00010	1	NUT 10 (L-H)	10*P1.25		
34	+	900300-20022	1	PIN, SPLIT 2*22	2*22		
35	+	610443-22830	1	PLATE, GUARD (WH)			
37		699200-08931	1	CUP ASSY, FREE			
38	+	610314-04631	1	PLATE, ADAPTER (L)			
39	+	699226-05430	1	HOLDER, BEARING			

8. Gear Case(U-Handle Type), Blade No.8

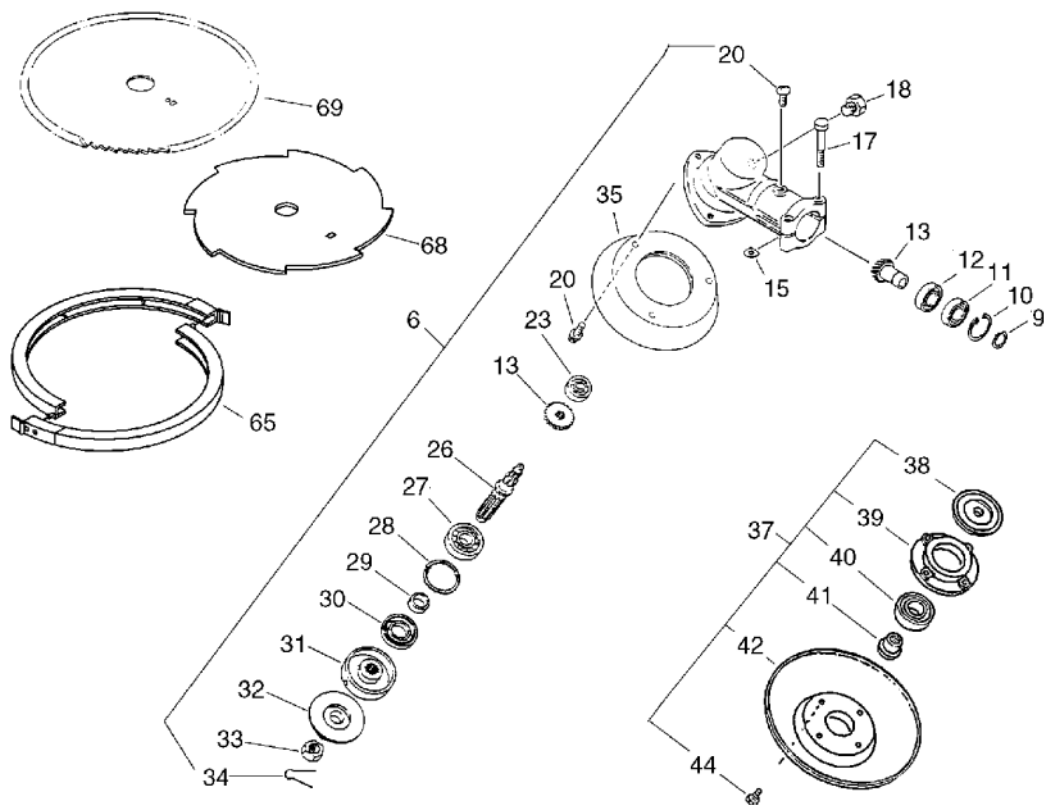

KEY	LV	PART NUMBER	Q'TY	DESCRIPTION	REMARKS	NOTE1	NOTE2
40	+	900814-06202	1	BEARING, BALL 6202	6202ZZ		
41	+	699227-04630	1	NUT			
42	+	699228-08930	1	PLATE, COVER			
44	+	900141-05012	4	BOLT 5*12	5*12		
65		898523-50030	1	SCABBARD, BLADE		Sus. by P021-007470	
65		898523-47130	1	SCABBARD, BLADE		Sus. by P021-007470	
65		P021-007470	1	SCABBARD, BLADE			
68		696001-44730	1	BLADE, 8-CUTTER 9IN		Sus. by 696001-44731	
68		696001-44731	1	BLADE, 8-CUTTER 9IN	230*8T*1.4 PD25		
69		695001-27230	1	SAW, CIRCULAR 9*80P		Sus. by 695001-44731	
69		695001-44730	1	SAW, CIRCULAR 9*80T		Sus. by 695001-44731	
69		695001-44731	1	SAW, CIRCULAR 9*80T	230*80P*1.4 PD25		

9. Loop Handle

No.9

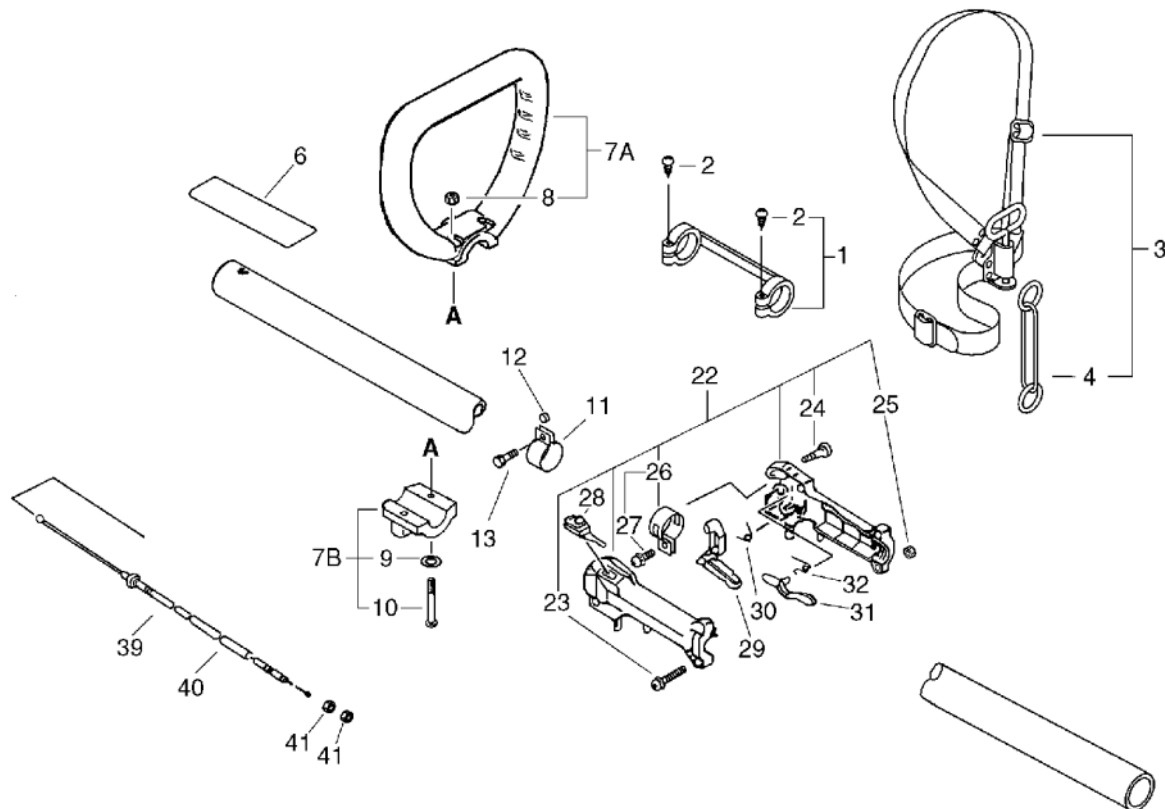

KEY	LV	PART NUMBER	Q'TY	DESCRIPTION	REMARKS	NOTE1	NOTE2
1		610280-46730	1	COLLAR		Sus. by 610281-46730	
1		610281-46730	1	COLLAR			
2	+	900253-04025	2	SCREW 4*25	4*25		
3		301000-55230	1	HARNESS ASSY		Sus. by 301000-55231	
3		301000-55231	1	HARNESS ASY, SHOULDER			
4	+	301305-24330	1	LINK			
6		890160-46730	1	LABEL, CAUTION		Sus. by 890617-43130	
6		890617-63630	1	LABEL, CAUTION		Sus. by 890617-43130	
6		X505-000140	1	LABEL, CAUTION		Sus. by 890617-43130	
6		890617-43130	1	LABEL, CAUTION			
7		351201-08930	1	HANDLE ASSY, LOOP			
8	+	900500-00005	2	NUT 5	5		
9	+	900600-00005	2	WASHER 5	5		
10	+	900220-05040	2	SCREW 5*40	5*40		
11		301207-08930	1	HOOK			
12		699012-03330	1	SPACER			
13		900100-05018	1	BOLT 5*18	5*18		
22		351102-29430	1	GRIP ASSY, F-HANDLE			
23	+	900238-05025	1	SCREW 5*25	5*25		
24	+	900253-04018	3	SCREW TAPPING 4*18	4*18		
25	+	900500-00005	1	NUT 5	5		

9. Loop Handle

No.9

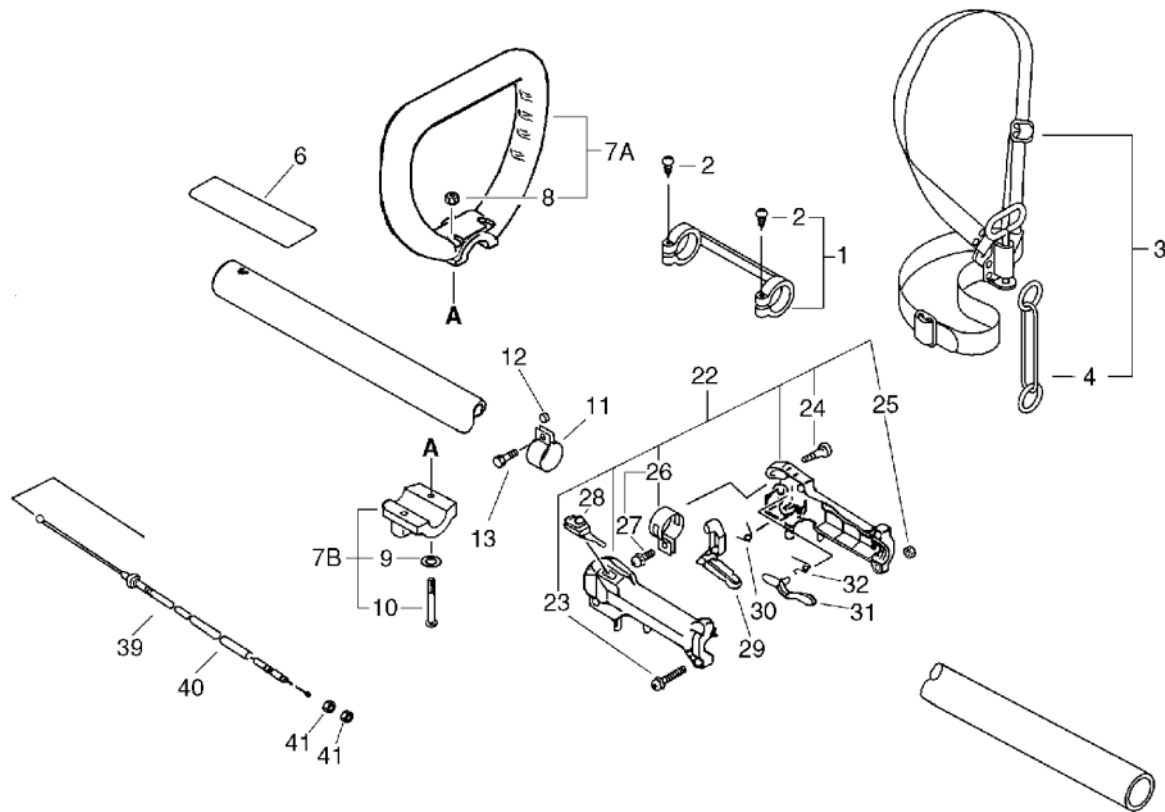

KEY	LV	PART NUMBER	Q'TY	DESCRIPTION	REMARKS	NOTE1	NOTE2
26	+	301200-29430	1	BAND ASSY			
27	++	900238-05012	1	SCREW 5*12	5*12		
28		163400-52430	1	SWITCH, IGNITION			
29		178010-42232	1	CONTROL, THROTTLE			
30		178043-42230	1	SPRING, THR. RETURN			
31		178012-42230	1	LOCKOUT, THROTTLE			
32		178013-42230	1	SPRING, THR. LOCKOUT			
35		890157-39130	1	LABEL, SWITCH		Disuse	
39		178001-52430	1	WIRE, THROTTLE			
40		178127-24030	1	TUBE	10*11*160		
41		900502-00006	2	NUT 6 (3N)	3N6		

10. Gear Case(Loop Handle Type), Nylon Line Cutting Head

No.10

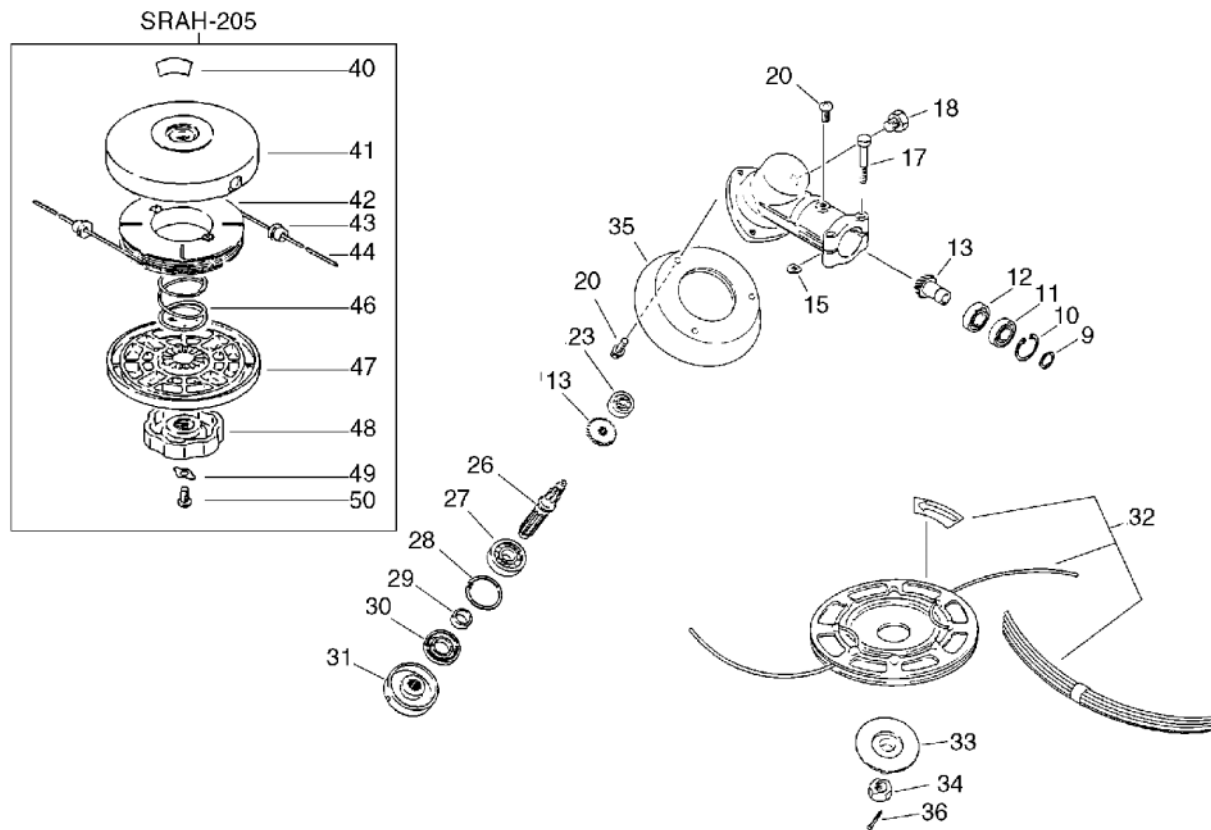

KEY	LV	PART NUMBER	Q'TY	DESCRIPTION	REMARKS	NOTE1	NOTE2
9		900706-00010	1	CIRCLIP 10	WR-10		
10		900702-00022	1	CIRCLIP 22	CR-22		
11		900858-06900	1	BEARING, BALL 6900Z	6900Z		
12		900855-06900	1	BEARING, BALL 6900	6900		
13		610300-25531	1	GEAR SET	7S		
15		610239-04130	2	WASHER, SHIM			
17		900142-05028	2	BOLT 5*28 (W/W,SW)	5*28		
18		610434-50030	1	BOLT 8* 6		Sus. by 610434-50031	
18		610434-50031	1	BOLT 8* 8	M8*8		
20		900242-05010	4	SCREW 5*10	5*10		
23		900810-00626	1	BEARING, BALL 626	626		
26		610310-40830	1	SHAFT, P.T.O.			
27		900800-06000	1	BEARING, BALL 6000	6000		
28		900702-00026	1	CIRCLIP 26	CR-26		
29		610315-22830	1	SPACER			
30		610413-22830	1	OILSEAL			
31		610313-44630	1	PLATE, ADAPTER		D. shaft Sr/Nr 006080 and before	
31		610313-22830	1	PLATE, ADAPTER (U)		D. shaft Sr/Nr 006081 and after	
32		696200-55230	1	CUTTER ASSY, LINE		Sus. by 990109-09040	
32		990109-09040	1	CUTTER BLACK			

10. Gear Case(Loop Handle Type), Nylon Line Cutting Head

No.10

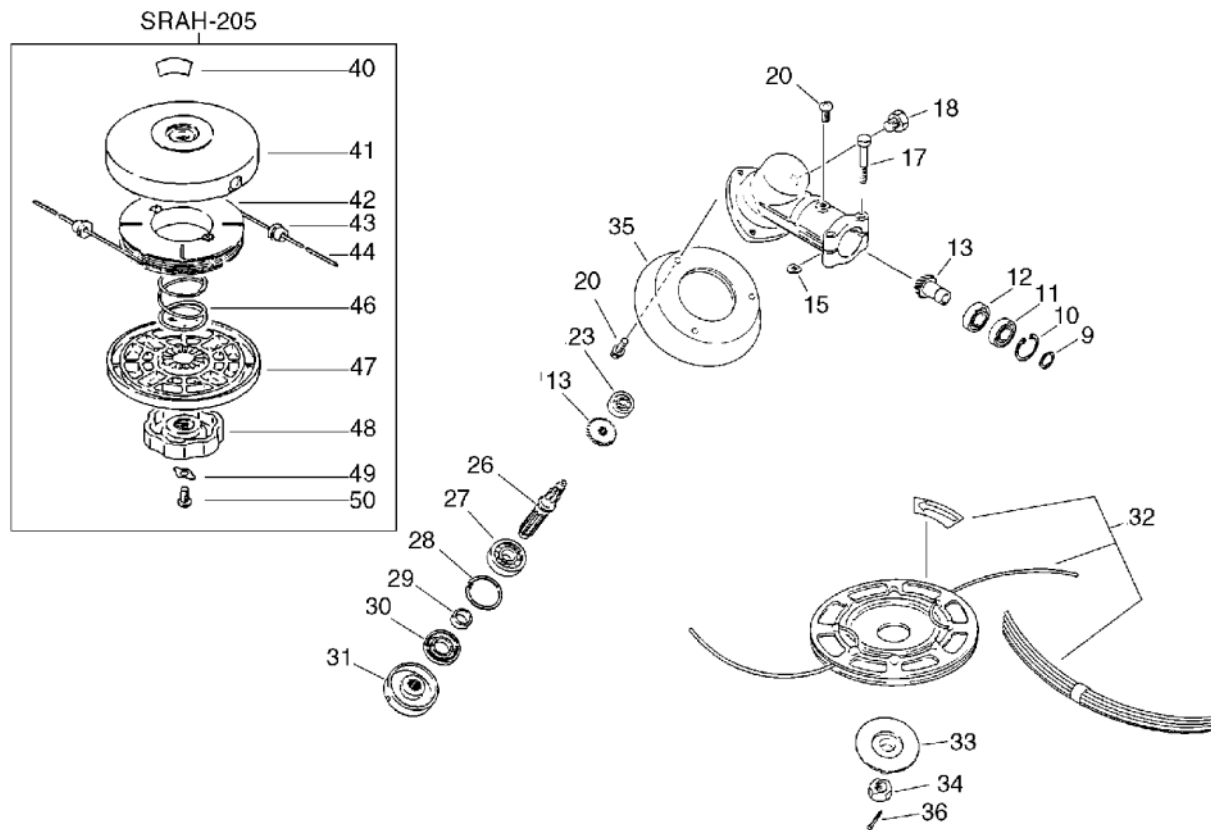

KEY	LV	PART NUMBER	Q'TY	DESCRIPTION	REMARKS	NOTE1	NOTE2
33		610314-27230	1	PLATE, ADAPTER			
34		900511-00010	1	NUT 10 (L-H)	10*P1.25	D. shaft Sr/Nr 006081 and after	
35		610443-22830	1	PLATE, GUARD (WH)			
36		900300-20022	1	PIN, SPLIT 2*22	2*22	D. shaft Sr/Nr 006081 and after	
40		890617-46730	1	LABEL, CAUTION			
41		696205-06033	1	DRUM, CORD REEL			
42		696214-06830	1	REEL, CORD			
43		696212-06032	2	EYELET			
44		696215-22830	2	CORD, NYLON(2.4*2.5)			
46		696216-06030	1	SPRING			
47		696206-06032	1	COVER, DRUM (JY)			
48		696219-06031	1	NUT (JY)		Sus. by V299- 000260	
48		V299-000260	1	KNOB,FASTENER	M16X2		
49		696220-06030	1	STOPPER, NUT			
50		900220-06010	1	SCREW 6*10	6*10		

11. Repair Kit

KEY	LV	PART NUMBER	Q'TY	DESCRIPTION	REMARKS	NOTE1	NOTE2
		125303-42030	1	GASKET/DIAPHRAGM KIT			
5-3	+	125341-42030	1	DIAPHRAGM			
5-4	+	125340-42030	1	GASKET, DIAPHRAGM			
5-22	+	125312-12820	1	DIAPHRAGM, FUEL PUMP			
5-23	+	125325-13310	1	GASKET, PUMP			
		125300-12620	1	REBUILD KIT			
5-3	+	125341-42030	1	DIAPHRAGM			
5-4	+	125340-42030	1	GASKET, DIAPHRAGM			
5-6	+	125338-13930	1	PIN, METERING ARM			
5-7	+	125323-42030	1	LEVER, METERING			
5-8	+	125322-12620	1	SPRING, COIL			
5-9	+	125337-06960	1	VALVE, INLET NEEDLE			
5-11	+	125345-15130	1	PLUG, WELCH			
5-21	+	125326-42030	1	STRAINER			
5-22	+	125312-12820	1	DIAPHRAGM, FUEL PUMP			
5-23	+	125325-13310	1	GASKET, PUMP			

Index

Patrs Number	Key No.	Patrs Number	Key No.	Patrs Number	Key No.
100000-55230	1 - 15	125326-42030	11 - 5-21	131051-52430	4 - 21
100011-05330	1 - 16	125326-42030	5 - 21	131205-14930	4 - 11
100013-22330	1 - 17	125327-13930	5 - 19	131300-49930	4 - 4
100014-11520	1 - 20	125327-15130	5 - 10	131300-56430	4 - 4
100015-04630	1 - 18	125333-08560	5 - 30	131924-40930	4 - 23
100100-55230	1 - 21	125334-13930	5 - 29	131925-22330	4 - 13
100100-55231	1 - 21	125337-06960	11 - 5-9	132010-13930	4 - 12
100100-55232	1 - 21	125337-06960	5 - 9	132010-56330	4 - 6
100204-55230	1 - 25	125338-13930	11 - 5-6	132012-51030	4 - 6
100204-55231	1 - 25	125338-13930	5 - 6	132013-09820	4 - 9
100212-42030	1 - 27	125339-42030	5 - 5	132115-46730	4 - 8
100212-42031	1 - 27	125340-42030	11 - 5-4	145510-55230	3 - 25
100215-03930	1 - 28	125340-42030	11 - 5-4	145610-55230	3 - 26
100242-55230	1 - 29	125340-42030	5 - 4	150112-44330	2 - 10
101010-22331	1 - 14	125341-42030	11 - 5-3	156111-55230	2 - 9
101011-55230	1 - 13	125341-42030	11 - 5-3	156626-55230	2 - 11
101503-55230	6 - 8	125341-42030	5 - 3	156626-55231	2 - 11
101514-55230	1 - 8	125342-13210	5 - 2	156801-55230	2 - 20
101531-55230	1 - 10	125342-52130	5 - 2	156801-55231	2 - 20
101534-55230	6 - 10	125344-08560	5 - 29	159010-10230	2 - 5
125200-55230	3 - 9	125344-52130	5 - 1	159011-03432	2 - 6
125200-55230	5 -	125345-15130	11 - 5-11	159012-01620	2 - 8
125200-55231	3 - 9	125345-15130	5 - 11	159015-55230	2 - 7
125200-55231	5 -	125363-11610	5 - 27	159902-55230	1 - 4
125200-55232	3 - 9	125372-42030	5 - 20	162014-27230	2 - 21
125200-55232	5 -	125376-55230	5 - 31	163400-48030	7 - 12
125300-12620	11 -	125378-13930	5 - 30	163400-52430	9 - 28
125303-42030	11 -	125381-08660	5 - 26	175005-40930	6 - 4
125310-11610	5 - 28	125381-46730	5 - 26	175009-05532	2 - 15
125312-12820	11 - 5-22	125383-13310	5 - 24	175012-03930	1 - 19
125312-12820	11 - 5-22	129011-51730	3 - 15	175018-05535	2 - 14
125312-12820	5 - 22	130007-51231	3 - 6	175046-22332	2 - 13
125312-42030	5 - 22	130010-55230	3 - 5	175048-05530	2 - 16
125313-42030	5 - 17	130016-42031	3 - 7	177200-55230	2 - 28
125314-13930	5 - 13	130111-00530	4 - 5	177202-55230	2 - 25
125316-07260	5 - 12	130301-51730	3 - 11	177215-40630	2 - 30
125317-42030	5 - 18	130302-51730	3 - 19	177218-55230	2 - 27
125318-42030	5 - 16	130302-51731	3 - 19	177220-40630	2 - 31
125319-42030	5 - 14	130302-52130	3 - 19	177226-40630	2 - 32
125320-51030	5 - 15	130302-52131	3 - 19	177227-05330	2 - 33
125322-12620	11 - 5-8	130310-51730	3 - 17	177228-06530	2 - 34
125322-12620	5 - 8	130406-16331	3 - 21	177234-40630	2 - 26
125323-42030	11 - 5-7	130406-52130	3 - 21	177236-40630	2 - 29
125323-42030	5 - 7	130406-52131	3 - 21	178001-47530	7 - 14
125324-11610	5 - 24	131004-08960	4 - 19	178001-52430	9 - 39
125325-13310	11 - 5-23	131004-46730	4 - 19	178010-05960	7 - 11
125325-13310	11 - 5-23	131010-41930	4 - 14	178010-42232	9 - 29
125325-13310	5 - 23	131016-40930	4 - 20	178012-05960	7 - 9
125325-42030	5 - 23	131016-55830	4 - 20	178012-42230	9 - 31

Index

Patrs Number	Key No.	Patrs Number	Key No.	Patrs Number	Key No.
178013-35631	7 - 10	610413-22830	10 - 30	897518-01131	6 - 52
178013-42230	9 - 32	610413-22830	8 - 30	898502-01130	6 - 53
178043-42230	9 - 30	610434-50030	10 - 18	898523-47130	8 - 65
178111-04930	7 - 13	610434-50030	8 - 18	898523-50030	8 - 65
178127-24030	9 - 40	610434-50031	10 - 18	900100-05012	7 - 31
178127-47530	7 - 15	610434-50031	8 - 18	900100-05018	9 - 13
178510-51730	3 - 10	610443-22830	10 - 35	900105-05060	3 - 27
178515-05060	3 - 14	610443-22830	8 - 35	900141-05012	8 - 44
178516-00830	3 - 13	610903-55230	6 - 13	900142-05025	6 - 14
178810-05230	3 - 12	610910-55230	6 - 12	900142-05025	6 - 38
301000-44730	7 - 22	695001-27230	8 - 69	900142-05025	7 - 20
301000-55230	9 - 3	695001-44730	8 - 69	900142-05028	10 - 17
301000-55231	9 - 3	695001-44731	8 - 69	900142-05028	8 - 17
301015-05330	7 - 33	696001-44730	8 - 68	900142-06030	7 - 21
301200-21330	7 - 30	696001-44731	8 - 68	900162-05020	1 - 12
301200-29430	9 - 26	696200-55230	10 - 32	900162-05025	3 - 8
301205-21330	7 - 32	696205-06033	10 - 41	900220-05030	7 - 7
301207-08930	9 - 11	696206-06032	10 - 47	900220-05040	9 - 10
301305-24330	9 - 4	696212-06032	10 - 43	900220-06010	10 - 50
305110-40930	4 - 24	696214-06830	10 - 42	900238-04008	6 - 9
351102-29430	9 - 22	696215-22830	10 - 44	900238-04014	2 - 35
351102-47530	7 - 5	696216-06030	10 - 46	900238-04022	2 - 12
351110-52430	7 - 23	696219-06031	10 - 48	900238-05010	2 - 22
351201-08930	9 - 7	696220-06030	10 - 49	900238-05010	3 - 29
351202-51430	7 - 16	699001-44730	6 - 29	900238-05010	4 - 25
351210-52430	7 - 18	699010-54430	6 - 30	900238-05012	1 - 7
351301-09230	7 - 19	699011-27230	6 - 31	900238-05012	9 - 27
351311-02330	7 - 24	699012-03330	9 - 12	900238-05020	1 - 9
352325-55230	1 - 5	699013-52130	6 - 32	900238-05020	6 - 11
437210-11131	4 - 7	699015-52130	6 - 37	900238-05025	9 - 23
610011-25530	6 - 23	699016-52130	6 - 39	900238-05050	3 - 16
610206-23030	6 - 20	699016-54530	6 - 39	900242-05010	10 - 20
610239-04130	10 - 15	699200-08931	8 - 37	900242-05010	8 - 20
610239-04130	8 - 15	699226-05430	8 - 39	900242-05012	6 - 40
610280-46730	9 - 1	699227-04630	8 - 41	900242-05014	6 - 36
610281-46730	9 - 1	699228-08930	8 - 42	900242-05018	6 - 33
610300-25531	10 - 13	890112-55230	1 - 11	900242-05020	7 - 17
610300-25531	8 - 13	890118-49330	2 - 36	900242-05028	1 - 26
610310-40830	10 - 26	890121-47530	3 - 18	900246-03025	7 - 6
610310-40830	8 - 26	890152-04930	6 - 21	900253-04018	9 - 24
610313-22830	10 - 31	890157-39130	7 - 4	900253-04025	9 - 2
610313-22830	8 - 31	890157-39130	9 - 35	900300-20022	10 - 36
610313-44630	10 - 31	890160-46730	9 - 6	900300-20022	8 - 34
610314-04631	8 - 38	890617-43130	7 - 28	900500-00005	6 - 35
610314-27230	10 - 33	890617-43130	9 - 6	900500-00005	7 - 8
610314-27230	8 - 32	890617-46730	10 - 40	900500-00005	7 - 8
610315-22830	10 - 29	890617-63630	9 - 6	900500-00005	9 - 8
610315-22830	8 - 29	895112-00330	6 - 51	900500-00005	9 - 25
610400-52430	8 - 6	895410-08030	6 - 50	900502-00006	7 - 48

Index

Patrs Number	Key No.	Patrs Number	Key No.	Patrs Number	Key No.
900502-00006	9 - 41				
900502-00008	2 - 17				
900511-00010	10 - 34				
900511-00010	8 - 33				
900600-00005	3 - 28				
900600-00005	9 - 9				
900600-00008	2 - 19				
900603-00005	6 - 34				
900605-00008	2 - 18				
900701-00012	6 - 6				
900702-00022	10 - 10				
900702-00022	8 - 10				
900702-00026	10 - 28				
900702-00026	8 - 28				
900702-00028	6 - 7				
900706-00010	10 - 9				
900706-00010	8 - 9				
900720-00003	3 - 20				
900720-00004	1 - 6				
900800-06000	10 - 27				
900800-06000	8 - 27				
900807-06001	6 - 5				
900810-00626	10 - 23				
900810-00626	8 - 23				
900810-36201	1 - 30				
900814-06202	8 - 40				
900855-06900	10 - 12				
900855-06900	8 - 12				
900858-06900	10 - 11				
900858-06900	8 - 11				
94035-36201	1 - 30				
990109-09040	10 - 32				
P005-000990	5 - 24				
P021-000460	7 - 19				
P021-007470	8 - 65				
V299-000260	10 - 48				
V471-001190	4 - 12				
V471-001210	4 - 7				
X505-000140	9 - 6				
X602-000020	6 - 50				

YAMABIKO CORPORATION

7-2 SUEHIROCHO 1-CHOME, OHME, TOKYO 198-8760, JAPAN
PHONE: 81-428-32-6118. FAX: 81-428-32-6145.



2600
No.