



PARTS CATALOGUE

CHAIN SAW CS-900EVL

CS-900EVL

1. Cylinder, Crankcase, Starter, Magneto, Clutch, Sprocket, Chain No.1

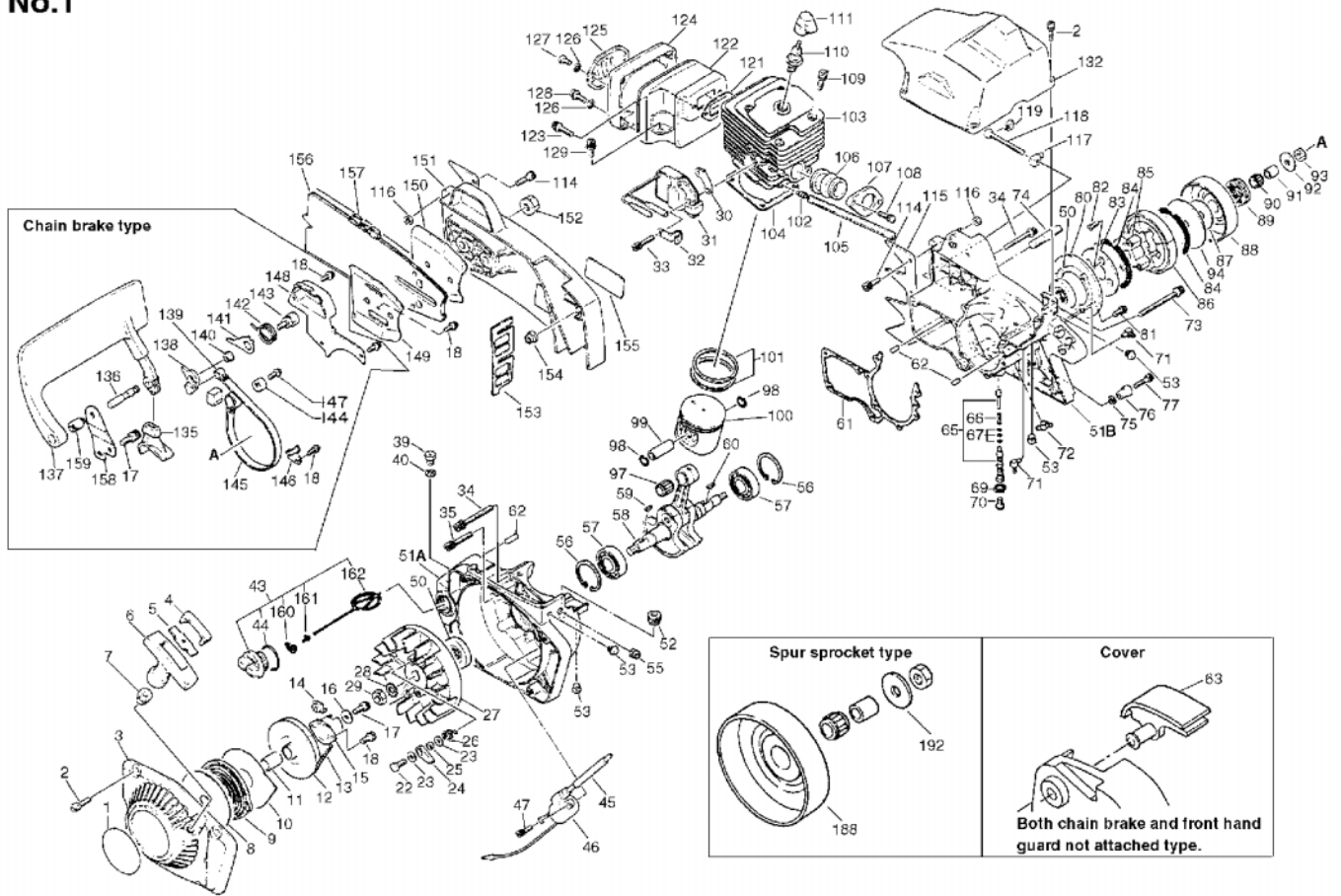

KEY	LV	PART NUMBER	Q'TY	DESCRIPTION	REMARKS	NOTE1	NOTE2
1		890118-17930	1	LABEL, ECHO			
2		101512-14730	7	SCREW	5*20		
		177200-14730	1	STARTER ASS'Y (BS)			
3	+	101507-14730	1	COVER, FAN (BS)			
4	+	177244-10630	1	CAP, GRIP			
5	+	177229-14730	1	WASHER, STARTER GRIP			
6	+	177228-10631	1	GRIP, STARTER			
7	+	177227-10630	1	GUIDE, ROPE		Sus. by 177227-07060	
7	+	177227-07060	1	GUIDE, ROPE			
8	+	177221-10630	1	PLATE, STARTER			
9	+	177220-10631	1	SPRING, REWIND			
10	+	177242-14730	1	PLATE, STARTER			
11	+	177216-10630	1	COLLAR			
12	+	177215-10632	1	DRUM, STARTER			
13	+	177226-14730	1	ROPE, STARTER	5.0*1050		
14	+	177246-10631	1	CLIP, STARTER ROPE			
15	+	177243-02833	1	CATCHER, PAWL			
16	+	300217-00610	1	WASHER			
17	+	900162-05015	1	BOLT, H.S. 5*15	5*15 W,SW		
18	+	900242-04012	2	SCREW 4*12	4*12		
18		900242-04012	1	SCREW 4*12	4*12		
22		900100-06016	2	BOLT 6*16	6*16		
23		900600-00006	4	WASHER 6	6		
24		177218-02830	2	RATCHET			
25		177247-02830	2	SPACER, RATCHET			

Brake

1. Cylinder, Crankcase, Starter, Magneto, Clutch, Sprocket, Chain No.1

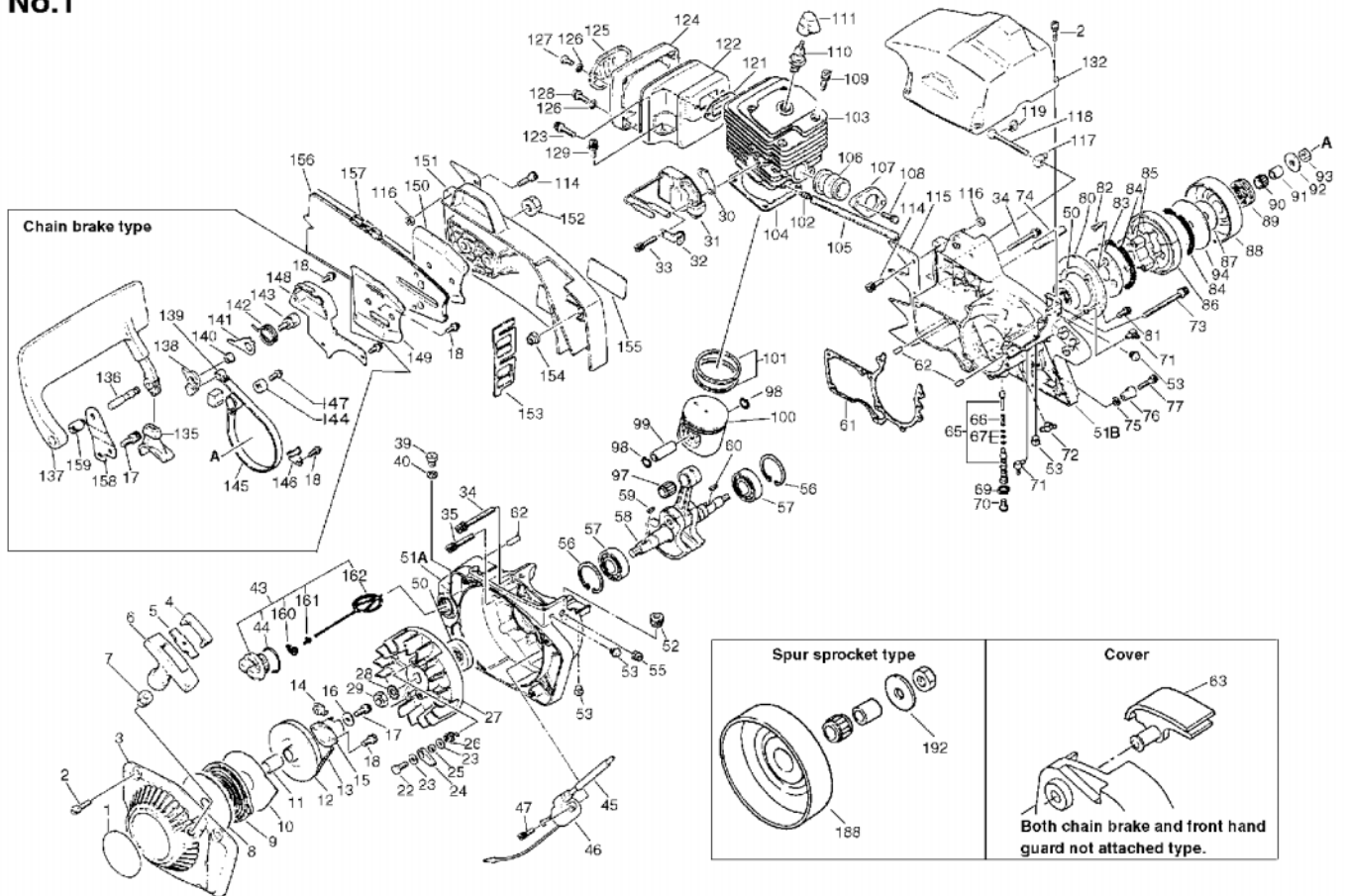

KEY	LV	PART NUMBER	Q'TY	DESCRIPTION	REMARKS	NOTE1	NOTE2
26		177234-14730	2	SPRING, RETURN			
27		156801-14730	1	FLYWHEEL			
28		900611-00010	1	LOCKWASHER 10	TWB10		
29		100144-02830	1	NUT			
30		150617-14730	1	SPACER			
31		156601-14730	1	C.D. IGNITION MODULE			
32		159112-14730	1	CLIP			
33		900162-05025	2	BOLT, H.S. 5*25	5*25 W,SW		
34		900162-05050	4	BOLT, H.S. 5*50	5*50 W,SW		
35		900162-05035	4	BOLT, H.S. 5*35	5*35 W,SW		
39		436100-00230	1	VENT ASS'Y			
40	+	131310-00230	1	GASKET			
43		436001-14733	1	CAP ASSY, OIL TANK			
44	+	900720-00025	1	O-RING 25	P-25		
160	+	131050-19830	1	RETAINER, LINK			
161	+	900246-03008	1	SCREW 3*8	3*8		
162	+	131051-19830	1	LINK	60L		
45		150611-14730	1	TUBE	7*8.6*130		
46		156626-14730	1	COIL, IGNITION			
47		900162-04016	2	BOLT, H.S. 4*16	4*16 W,SW		
50		100212-12130	2	OILSEAL	ISCMD17*40*6		
51		100204-14734	1	CRANKCASE KIT			
61	+	100242-14731	1	GASKET, CRANKCASE			
62	+	100215-02830	4	PIN, DOWEL			
71	+	437239-14730	2	NIPPLE			
72	+	437201-14730	1	CONNECTOR KIT			

Brake

1. Cylinder, Crankcase, Starter, Magneto, Clutch, Sprocket, Chain No.1

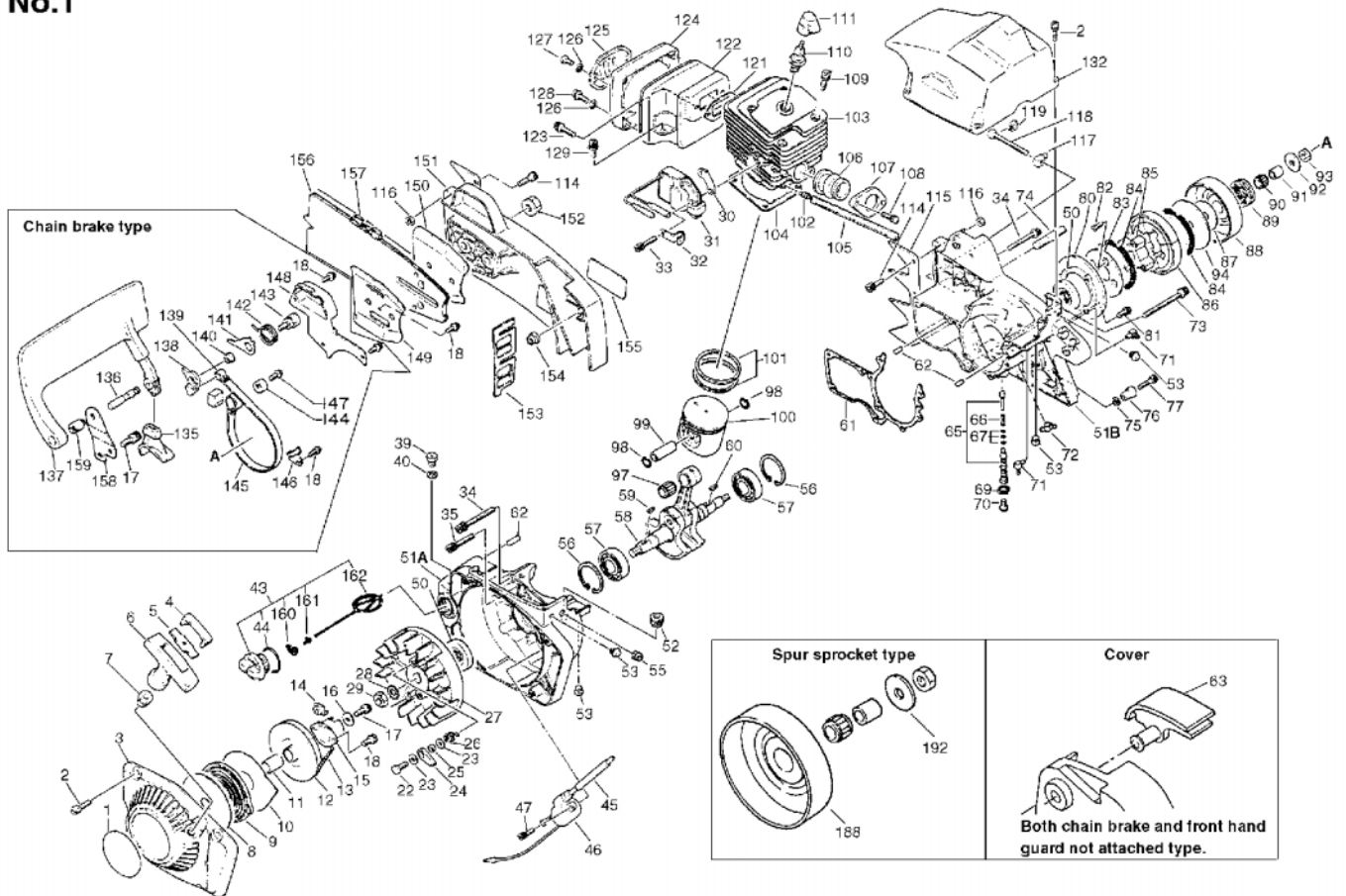

KEY	LV	PART NUMBER	Q'TY	DESCRIPTION	REMARKS	NOTE1	NOTE2
52		153110-02830	1	BUSHING			
53		100251-14730	4	CUSHION			
55		132115-01461	1	GROMMET			
56		900702-00040	2	CIRCLIP 40	CR-40		
57		900810-06203	2	BEARING, BALL 6203	6203		
58		100100-14731	1	CRANKSHAFT ASSY			
59		100142-12330	1	KEY, WOODRUFF			
60		900322-03014	1	KEY, WOODRUFF 3*14	3*14		
63		100612-12332	1	COVER			
65		437000-03430	1	AUTO-OILER ASS'Y			
66	+	437019-02830	1	SPRING, OILER			
67	+	437020-02830	3	O-RING (S-5)			
69		437059-11133	1	LOCKWASHER			
70		900220-05010	1	SCREW 5*10	5*10		
73		900162-05065	1	BOLT, H.S. 5*65	5*65 W,SW		
74		433011-10630	2	STUD, GUIDE BAR			
76		433000-12830	1	CATCHER KIT, CHAIN			
75	+	900600-00005	1	WASHER 5	5		
77	+	900105-05025	1	BOLT, H.S. 5*25	5*25		
80		175310-14730	1	PLATE			
81		900242-04010	3	SCREW 4*10	4*10		
82		900218-05012	4	SCREW 5*12	SF-5*12		
		175000-14730	1	CLUTCH ASSY			
83	+	175019-10631	1	PLATE, CLUTCH			
84	+	175018-14730	2	SPRING, CLUTCH			
85	+	175016-14730	1	HUB, CLUTCH			

Brake

1. Cylinder, Crankcase, Starter, Magneto, Clutch, Sprocket, Chain No.1

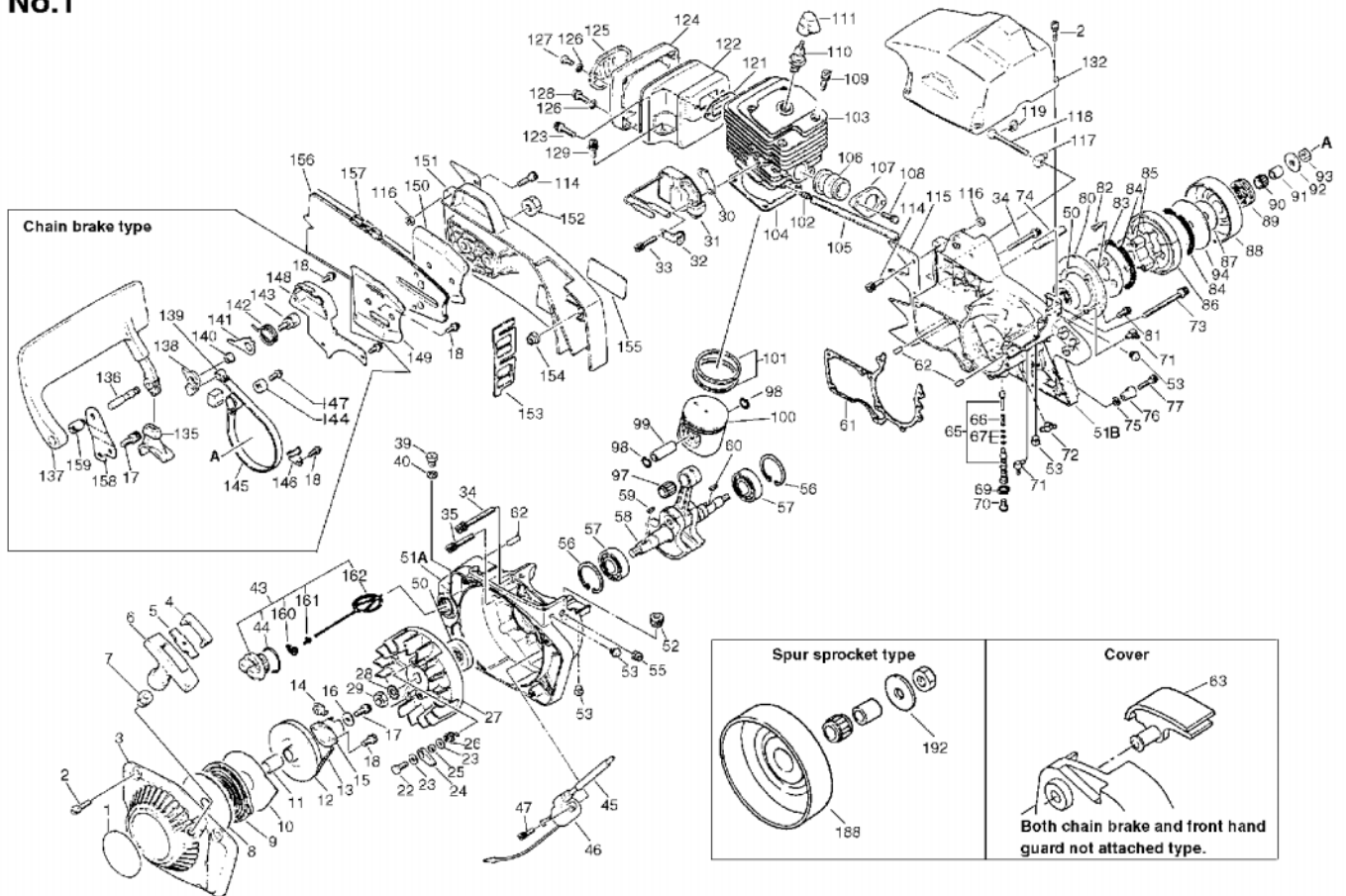

KEY	LV	PART NUMBER	Q'TY	DESCRIPTION	REMARKS	NOTE1	NOTE2
86	+	175017-14730	4	SHOE, CLUTCH			
87		175015-10630	1	WASHER, CLUTCH (I)			
88		175006-14730	1	DRUM, CLUTCH (.404)			
89		175033-10630	1	SPROCKET, RIM 22270			
90		175012-30830	1	BEARING, NEEDLE			
91		175013-00230	1	SPACER, CLUTCH DRUM			
92		175014-10630	1	WASHER, CLUTCH (O)	10.2*26*1.6		
93		100129-14730	1	NUT	10*1.25		
94		175044-14730	1	WASHER, CLUTCH			
100		100000-14732	1	PISTON KIT			
97	+	100012-14730	1	BEARING, NEEDLE			
98	+	100015-00230	2	CIRCLIP, PISTON PIN			
99	+	100013-14730	1	PIN, PISTON	7*12*34.5		
101	+	100011-14731	2	RING, PISTON			
102		100267-10630	1	CONNECTOR, IMPULSE			
103		101011-14732	1	CYLINDER			
104		101010-14731	1	GASKET, CYL. BASE			
105		437228-14730	1	PIPE, OIL			
106		130510-14731	1	ADAPTER, INTAKE			
107		130512-14731	1	HOLDER			
108		900242-05014	2	SCREW 5*14	5*14		
109		900160-06020	4	BOLT, H.S. 6*20	6*20 W		
110		159010-10630	1	PLUG, SPARK (BPM-7A)	BPM-7A		
111		159005-00331	1	CAP, SPARK PLUG			
114		900105-05015	6	BOLT, H.S. 5*15	5*15		
115		880212-14730	2	BUMPER, SPIKED			

Brake

1. Cylinder, Crankcase, Starter, Magneto, Clutch, Sprocket, Chain No.1

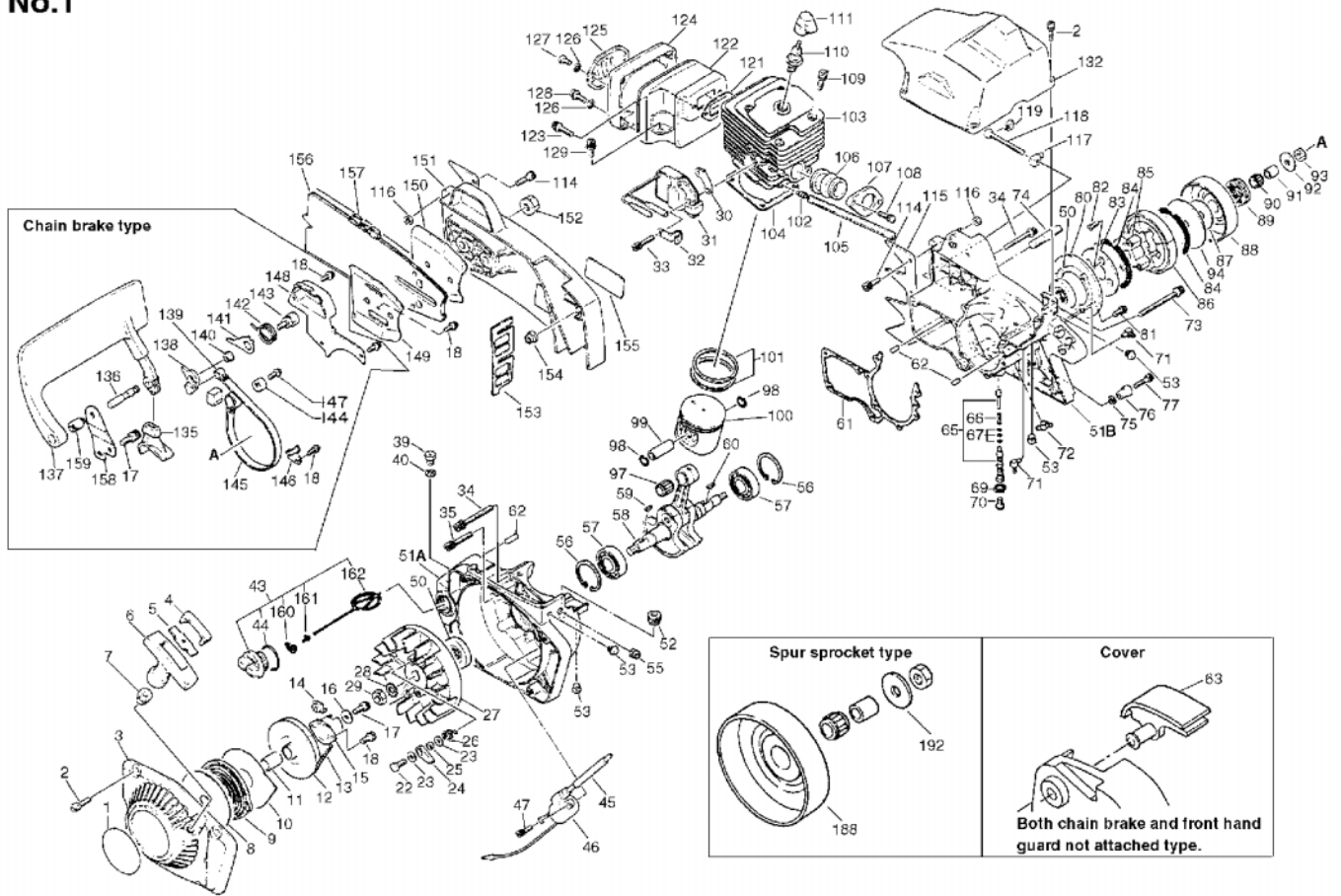

KEY	LV	PART NUMBER	Q'TY	DESCRIPTION	REMARKS	NOTE1	NOTE2
116		900560-00005	6	NUT, LOCK 5	5		
117		433014-10631	1	TENSIONER			
118		433016-14730	1	SCREW, TENSIONER			
119		433028-14730	1	CLIP			
121		145510-14732	1	GASKET, MUFFLER			
122		145806-14733	1	MUFFLER (BL)			
123		900169-06020	2	BOLT, H.S. 6*20	6*20		
124		145807-14730	1	MUFFLER (B) (BL)			
125		145861-14730	1	LID, MUFFLER (BL)			
126		900610-00005	6	LOCKWASHER 5	TWA5		
127		145643-03730	2	SCREW (5*8 CU)	+SR5*8CU		
128		145643-14730	4	SCREW (5*20 CU)	+SR5*20CU		
129		900162-05015	1	BOLT, H.S. 5*15	5*15 W,SW		
132		101514-14732	1	COVER, CYLINDER			
		433100-14731	1	BRAKE ASS'Y, CHAIN			
18	+	900242-04012	5	SCREW 4*12	4*12		
135	+	433312-12330	1	COVER, SEAL			
136	+	433113-12330	1	SCREW			
137	+	433105-14731	1	LEVER, BRAKE			
138	+	433117-14730	1	CONNECTOR			
139	+	433313-14730	1	SEAL, DUST			
140	+	433115-12330	1	SPACER			
141	+	433119-12330	1	STOPPER			
142	+	433114-12330	1	SPRING, RETURN			
143	+	433134-12330	1	BOLT			
144	+	433142-14730	1	ADJUSTER, BRAKE			

Brake

1. Cylinder, Crankcase, Starter, Magneto, Clutch, Sprocket, Chain No.1

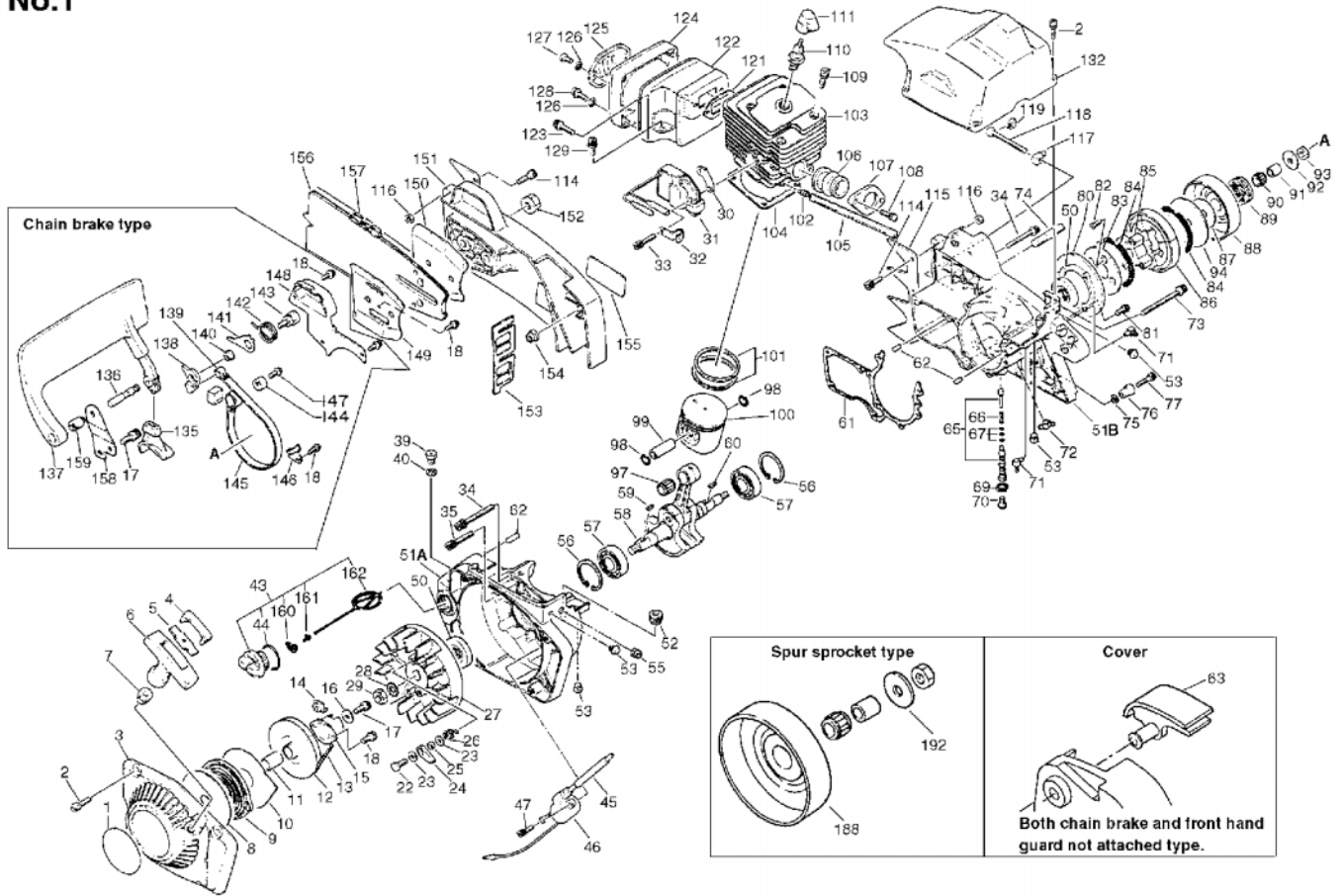

KEY	LV	PART NUMBER	Q'TY	DESCRIPTION	REMARKS	NOTE1	NOTE2
145	+	433123-14730	1	BAND, BRAKE			
146	+	433144-14730	1	RETAINER, BRAKE BAND			
147	+	900242-05014	1	SCREW 5*14	5*14		
148	+	433310-14730	1	COVER			
17	+	900162-05015	1	BOLT, H.S. 5*15	5*15 W,SW		
158	+	433158-14730	1	SUPPORTER, B. LEVER			
159	+	433159-14730	1	HAB, BRAKE			
149		433013-14730	1	PLATE, GUIDE (INNER)			
150		433012-14730	1	PLATE, GUIDE (OUTER)			
151		433010-14731	1	GUARD, SPROCKET (BS)			
152		433019-10631	2	NUT, FLANGE			
153		433025-14730	1	PAD			
154		433030-14730	1	PIN, DOWEL			
155		890118-35030	1	LABEL, ECHO			
156		430328-10630	1	BAR, GUIDE 65H63	65H63		
157		431133-32930	1	CHAIN, SAW 59CP-80E	59CP-80E 65C	Sus. by X289-000000	
157		X289-000000	1	CHAIN,SAW	59AC-80E		
188		175206-14730	1	DRUM, CLUTCH (C.B.)			
192		175214-14731	1	WASHER, CLUTCH DRUM			

Brake

2. Air Cleaner, Handle

No.2

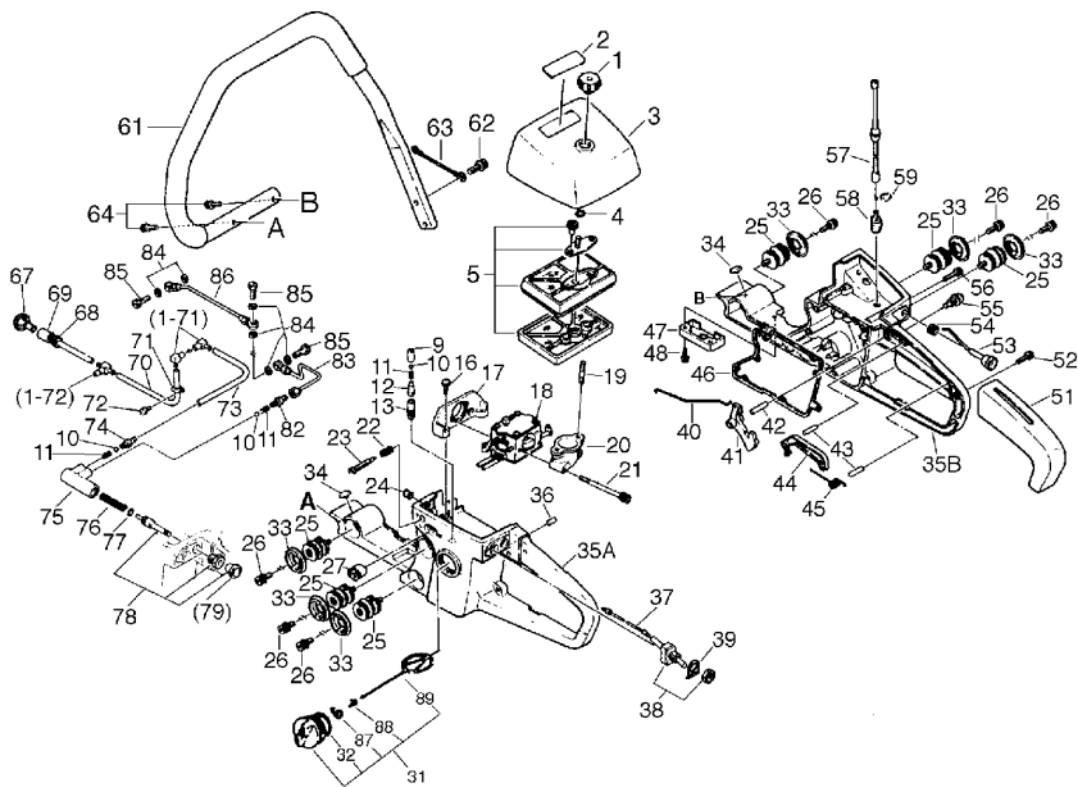

KEY	LV	PART NUMBER	Q'TY	DESCRIPTION	REMARKS	NOTE1	NOTE2
192		175214-14731	1	WASHER, CLUTCH DRUM			

3. Hand Guard, Carburetor

No.2

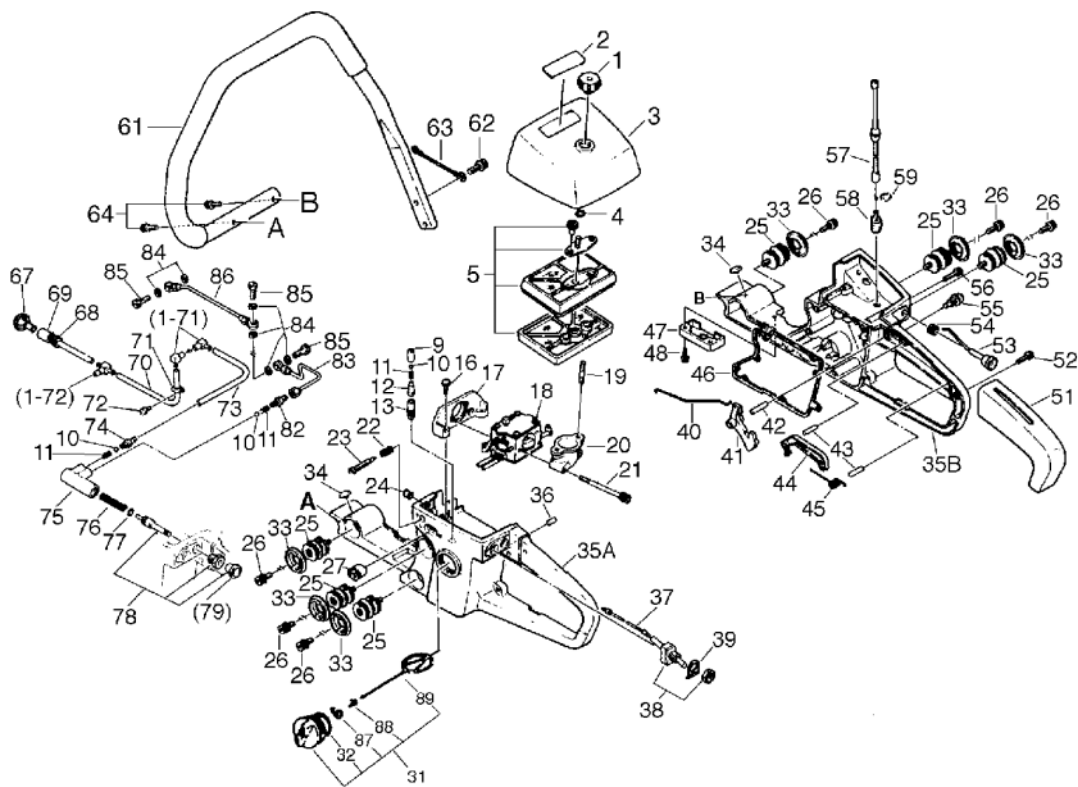

KEY	LV	PART NUMBER	Q'TY	DESCRIPTION	REMARKS	NOTE1	NOTE2
192		175214-14731	1	WASHER, CLUTCH DRUM			

4. Muffler

No.3

Hand Guard Type

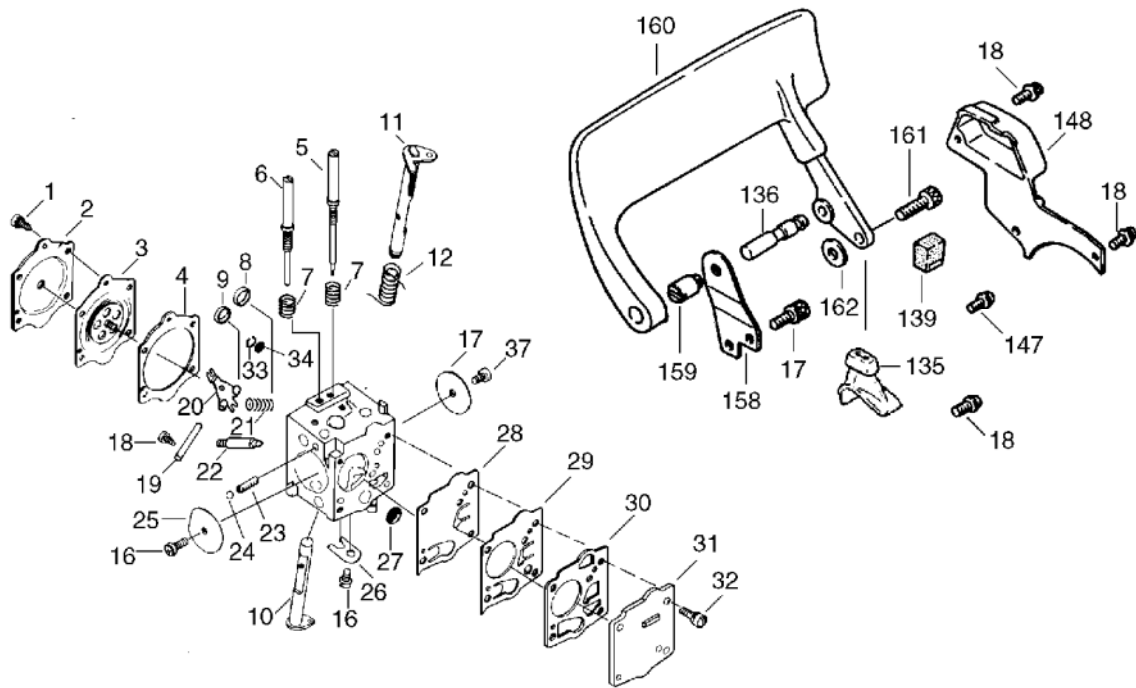

KEY	LV	PART NUMBER	Q'TY	DESCRIPTION	REMARKS	NOTE1	NOTE2
192		175214-14731	1	WASHER, CLUTCH DRUM			

Index

Patrs Number	Key No.	Patrs Number	Key No.	Patrs Number	Key No.
100000-14732	1 - 100	130712-14730	3 - 19	162021-14730	2 - 37
100011-14731	1 - 101	131004-14732	2 - 31	162021-14730	3 - 37
100012-14730	1 - 97	131004-14732	3 - 31	163400-11130	2 - 38
100013-14730	1 - 99	131011-14732	2 - 46	163400-11130	3 - 38
100015-00230	1 - 98	131011-14732	3 - 46	175000-14730	1 -
100100-14731	1 - 58	131050-19830	1 - 160	175006-14730	1 - 88
100129-14730	1 - 93	131050-19830	2 - 87	175012-30830	1 - 90
100142-12330	1 - 59	131050-19830	3 - 87	175013-00230	1 - 91
100144-02830	1 - 29	131051-19830	1 - 162	175014-10630	1 - 92
100204-14734	1 - 51	131051-19830	2 - 89	175015-10630	1 - 87
100212-12130	1 - 50	131051-19830	3 - 89	175016-14730	1 - 85
100215-02830	1 - 62	131205-19830	2 - 58	175017-14730	1 - 86
100215-02830	2 - 36	131300-14730	2 -	175018-14730	1 - 84
100215-02830	3 - 36	131300-14730	3 -	175019-10631	1 - 83
100242-14731	1 - 61	131310-00230	1 - 40	175033-10630	1 - 89
100251-14730	1 - 53	131320-14730	2 - 13	175044-14730	1 - 94
100253-14730	2 - 34	131320-14730	3 - 13	175206-14730	1 - 188
100253-14730	3 - 34	131326-14730	2 - 9	175214-14731	1 - 192
100267-10630	1 - 102	131326-14730	3 - 9	175310-14730	1 - 80
100612-12332	1 - 63	131327-14730	2 - 12	177200-14730	1 -
100905-14731	2 - 25	131327-14730	3 - 12	177215-10632	1 - 12
100905-14731	3 - 25	132010-02160	2 - 69	177216-10630	1 - 11
100918-14730	2 - 33	132010-14730	2 - 57	177218-02830	1 - 24
100918-14730	3 - 33	132115-01461	1 - 55	177220-10631	1 - 9
101010-14731	1 - 104	132115-01461	2 - 24	177221-10630	1 - 8
101011-14732	1 - 103	132115-01461	2 - 68	177226-14730	1 - 13
101507-14730	1 - 3	132115-01461	3 - 24	177227-07060	1 - 7
101512-14730	1 - 2	145405-14731	4 - 172	177227-10630	1 - 7
101514-14732	1 - 132	145510-14732	1 - 121	177228-10631	1 - 6
123000-14730	2 - 18	145606-14730	4 - 174	177229-14730	1 - 5
123000-14730	3 - 18	145643-03730	1 - 127	177234-14730	1 - 26
129010-14730	2 - 27	145643-14730	1 - 128	177242-14730	1 - 10
129010-14730	3 - 27	145805-14733	4 - 170	177243-02833	1 - 15
129013-14730	2 - 23	145806-14733	1 - 122	177244-10630	1 - 4
129013-14730	3 - 23	145807-14730	1 - 124	177246-10631	1 - 14
129020-14730	2 - 22	145861-14730	1 - 125	177247-02830	1 - 25
129020-14730	3 - 22	145868-10630	4 - 175	178010-14730	2 - 41
130013-14731	2 - 17	145873-14731	4 - 173	178010-14730	3 - 41
130013-14731	3 - 17	145880-14730	4 - 171	178011-14730	2 - 40
130300-14731	2 - 5	150611-14730	1 - 45	178011-14730	3 - 40
130300-14731	3 - 5	150617-14730	1 - 30	178090-14730	2 - 44
130313-14730	2 - 3	153110-02830	1 - 52	178090-14730	3 - 44
130313-14730	3 - 3	156601-14730	1 - 31	178091-10531	2 - 45
130406-00330	3 - 1	156626-14730	1 - 46	178091-10531	3 - 45
130510-14731	1 - 106	156801-14730	1 - 27	178302-12330	2 - 55
130512-14731	1 - 107	159005-00331	1 - 111	178510-14730	2 - 53
130711-14730	2 - 20	159010-10630	1 - 110	178810-02830	2 - 54
130711-14730	3 - 20	159112-14730	1 - 32	300217-00610	1 - 16
130712-14730	2 - 19	162010-14732	2 - 63	351100-14732	2 - 35

Index

Patrs Number	Key No.	Patrs Number	Key No.	Patrs Number	Key No.
351100-14732	3 - 35	437101-14730	2 - 78	900242-04010	2 - 72
351111-14730	2 - 51	437102-00330	2 - 75	900242-04012	1 - 18
351111-14730	3 - 51	437111-00231	2 - 76	900242-04012	1 - 18
351606-14731	2 - 61	437119-14731	2 - 79	900242-04012	1 - 18
430328-10630	1 - 156	437201-14730	1 - 72	900242-04012	2 - 48
431133-32930	1 - 157	437206-14733	2 - 83	900242-04012	3 - 48
433000-12830	1 - 76	437207-14731	2 - 86	900242-05014	1 - 108
433010-14731	1 - 151	437211-14730	2 - 70	900242-05014	1 - 147
433011-10630	1 - 74	437219-14730	2 - 84	900242-05020	2 - 16
433012-14730	1 - 150	437220-14732	2 - 85	900242-05020	3 - 16
433013-14730	1 - 149	437221-10530	2 - 59	900246-03008	1 - 161
433014-10631	1 - 117	437228-14730	1 - 105	900246-03008	2 - 88
433016-14730	1 - 118	437228-14730	2 - 73	900246-03008	3 - 88
433019-10631	1 - 152	437239-14730	1 - 71	900322-03014	1 - 60
433025-14730	1 - 153	437410-14730	2 - 71	900340-40020	2 - 43
433028-14730	1 - 119	437610-14731	2 - 47	900340-40020	3 - 43
433030-14730	1 - 154	437610-14731	3 - 47	900340-50025	2 - 42
433100-14731	1 -	880212-14730	1 - 115	900340-50025	3 - 42
433105-14731	1 - 137	890118-17930	1 - 1	900560-00005	1 - 116
433113-12330	1 - 136	890118-35030	1 - 155	900600-00005	1 - 75
433114-12330	1 - 142	890151-14730	2 - 2	900600-00006	1 - 23
433115-12330	1 - 140	890151-14730	3 - 2	900610-00005	1 - 126
433117-14730	1 - 138	890157-14730	2 - 39	900611-00010	1 - 28
433119-12330	1 - 141	890157-14730	3 - 39	900701-00011	2 - 4
433123-14730	1 - 145	900100-06016	1 - 22	900701-00011	3 - 4
433134-12330	1 - 143	900105-05015	1 - 114	900702-00040	1 - 56
433142-14730	1 - 144	900105-05025	1 - 77	900720-00006	2 - 77
433144-14730	1 - 146	900160-06020	1 - 109	900720-00025	1 - 44
433158-14730	1 - 158	900162-04016	1 - 47	900720-00029	2 - 32
433159-14730	1 - 159	900162-04016	2 - 52	900720-00029	3 - 32
433310-14730	1 - 148	900162-04016	3 - 52	900810-06203	1 - 57
433312-12330	1 - 135	900162-04020	2 - 56	X289-000000	1 - 157
433313-14730	1 - 139	900162-05015	1 - 17		
436001-14733	1 - 43	900162-05015	1 - 129		
436100-00230	1 - 39	900162-05015	1 - 17		
436205-14730	2 - 67	900162-05015	2 - 26		
437000-03430	1 - 65	900162-05015	3 - 26		
437012-00330	2 - 10	900162-05025	1 - 33		
437012-00330	2 - 10	900162-05035	1 - 35		
437012-00330	3 - 10	900162-05050	1 - 34		
437013-00330	2 - 11	900162-05065	1 - 73		
437013-00330	2 - 11	900162-05075	2 - 21		
437013-00330	3 - 11	900162-05075	3 - 21		
437017-00330	2 - 74	900162-06025	2 - 62		
437019-02830	1 - 66	900169-05020	2 - 64		
437020-02830	1 - 67	900169-06020	1 - 123		
437052-00330	2 - 82	900218-05012	1 - 82		
437059-11133	1 - 69	900220-05010	1 - 70		
437100-14730	2 -	900242-04010	1 - 81		

YAMABIKO CORPORATION

7-2 SUEHIROCHO 1-CHOME, OHME, TOKYO 198-8760, JAPAN
PHONE: 81-428-32-6118. FAX: 81-428-32-6145.



0EVL
No.